



# WORLDWIDE ELECTRIC MOTOR DATA SHEET

## IXPEWWE250-36-447/9TS



HORSEPOWER	<b>250</b>		
RPM / POLES	<b>3600 / 2</b>		
VOLTAGE / PHASE	<b>460 V / 3</b>		
FRAME	<b>447/9TS</b>		
ENCLOSURE / DEGREE OF PROTECTION	<b>TEFC / IP55</b>		
FREQUENCY	<b>60 HZ Suitable For 50 HZ Operation With 1.0 SF</b>		
FULL LOAD SPEED	<b>3585 RPM</b>		
SERVICE FACTOR	<b>1.15 SF</b>		
INSULATION CLASS	<b>F</b>		
FULL LOAD AMPS	<b>262 A</b>		
LOCKED ROTOR AMPS (STARTING)	<b>1825 A</b>		
NO LOAD CURRENT			
NEMA CODE LETTER	<b>G</b>		
EFFICIENCY / POWER FACTOR	<u>LOAD</u>	<u>EFF.</u>	<u>P.F.</u>
	<b>100%</b>	<b>95.8%</b>	<b>0.87</b>
	<b>75%</b>	<b>95.7%</b>	<b>0.89</b>
	<b>50%</b>	<b>95.3%</b>	<b>0.85</b>
DUTY CYCLE	<b>S1 / Continuous</b>		
TORQUE	<u>FULL LOAD</u>	<u>LRT</u>	<u>BDT</u>
	<b>368.4 lb.ft.</b>	<b>70%</b>	<b>175%</b>
SLIP	<b>0.42%</b>		
NEMA DESIGN	<b>B</b>		
MOMENT OF INERTIA			
NUMBER OF STARTS (Hot / Cold)	<b>1 Hot / 2 Cold (Per Hour)</b>		
MAX. AMBIENT TEMPERATURE	<b>40° C</b>		
MAX. ELEVATION	<b>3300 Ft. Above Sea Level</b>		
TEMPERATURE RISE (At Full Load)	<b>80° C</b>		
DE BEARING	<b>6314</b>		
ODE BEARING	<b>6314</b>		
GREASE TYPE	<b>Mobil Polyrex EM</b>		
MOUNTING	<b>F1 (F2 Convertible through UL Certified Shop Only)</b>		
ROTATION	<b>Bi-Directional</b>		
APPROXIMATE WEIGHT	<b>2370 lbs.</b>		
TEMPERATURE CODE AT 40°C AMBIENT	<b>T3C</b>		
TEMPERATURE CODE AT 55°C AMBIENT	<b>T2C</b>		
INVERTER RATING	<b>5:1 CT / 10:1 VT PWM Type</b>		





WORLDWIDE ELECTRIC MOTOR DRAWING

**IXPEWWE-447/9TS**

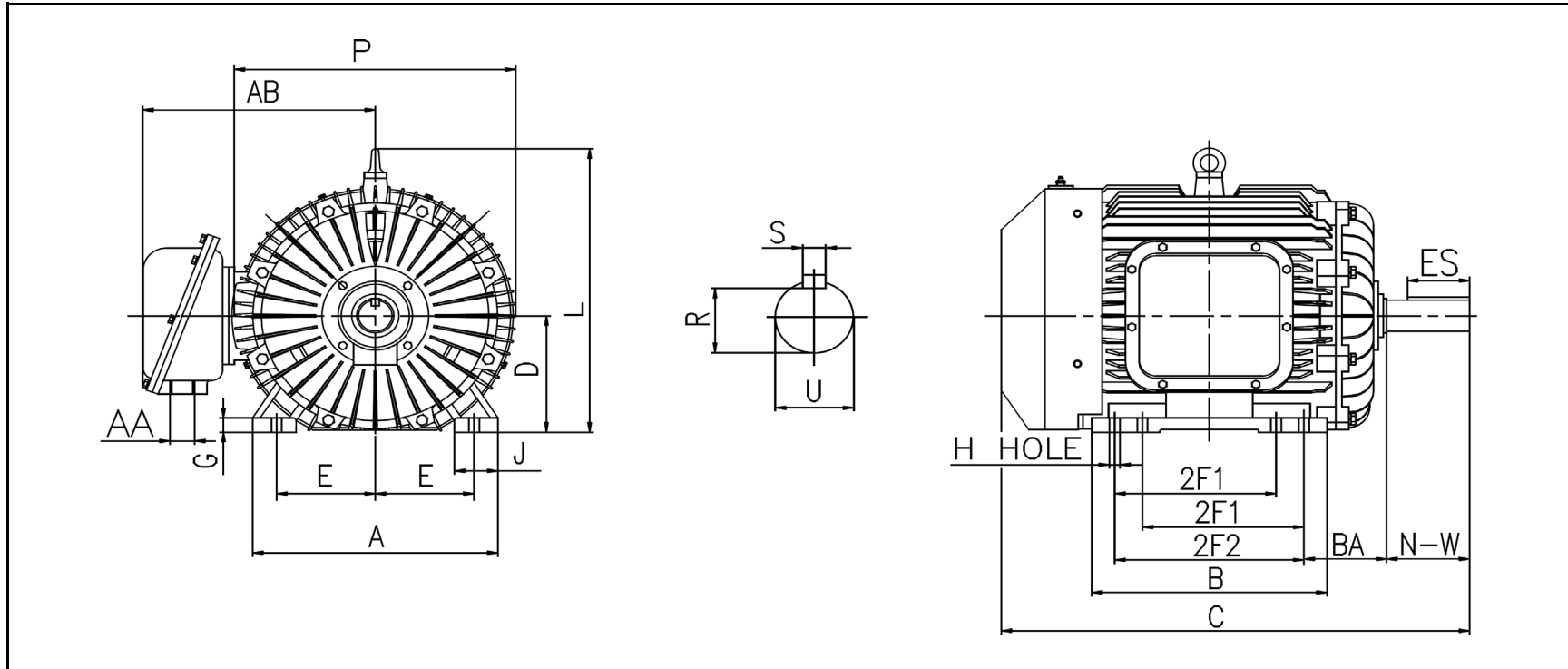

MOUNTING					A	B	C	D	G	J
E	2F1	2F2	H	BA	21.3	30.6	51.8	11	1.38	3.75
9	20	25	0.81	7.5						

L	P	AA	AB	KEY	KEYSEAT	SHAFT	N-W	U
28	24	3	21.3	ES	S	R	4.76	2.375
				3.03	0.625	2.021		

ALL DIMENSIONS IN INCHES

REVISED - 09/16/16