

INSTALLATION AND MAINTENANCE MANUAL



WORLDWIDE ELECTRIC THREE-PHASE MOTORS



WorldWide Electric Corporation
Phone: 1-800-808-2131 Ext. 3
Fax: 1-800-711-1616
Website: www.worldwideelectric.net



TABLE OF CONTENTS

SECTION I:	Motor Storage & Transport	Page 1
SECTION II:	Mounting – Foundation – Base	Page 2
SECTION III:	Motor Coupling	Page 3
SECTION IV:	Proper Running Conditions	Page 4
SECTION V:	Inspection Before Start-Up	Page 5
	Performance Data Sheet	Page 6
	Dimensional Drawing	Page 7
SECTION VI:	Starting Systems	Page 8
	Lead Wire Information	Page 9
SECTION VII:	Initial Motor Start-Up	Page 10
	Allowable Starts and Starting Intervals	Page 11
SECTION VIII:	Preventative Ongoing Maintenance	Page 12
	Relubrication Intervals	Page 13
	Lubrication Schedule	Page 14
SECTION IX:	Warranty Policy	Page 15-16
SECTION X:	Bearing Size Chart	Page 17
SECTION XI:	Shipping Crate Dimensions	Page 18-20
SECTION XII:	Double-Punched Motors	Page 21
SECTION XIII:	F1 / F2 Mounting	Page 22
SECTION XIV:	Conduit Hole Dimensions	Page 23
SECTION XV:	Guidelines For VFD Use	Page 24
SECTION XVI:	Decibel Levels (Sound Levels)	Page 25-28
SECTION XVII:	Fan Dimensions	Page 29-32
SECTION XVIII:	Junction Box Dimensions	Page 33-35
SECTION XIX:	Minimum Sheave Diameters	Page 36



WorldWide Electric Corporation
Phone: 1-800-808-2131 Ext. 3
Fax: 1-800-711-1616
Website: www.worldwideelectric.net



SECTION I:

Motor Storage & Transport

- A. Great care should be given to the transportation of all motors both small and large. Large motors should be in transportation crates with hard wood slat sides. Small motors should be individually boxed with protective packaging in the box surrounding the motor as well as the shaft of the motor. Motors come this way from the manufacturer and these guidelines should also be used when repackaging motors to ship to customers.
- B. All motors whether fractional or integral should be bolted to a platform that fits securely at the bottom of the crate or motor shipping box. The platform should be of plywood construction although hard cardboard, in many cases with smaller motors, will suffice. This prevents motors from shifting around during transport, banging the shafts and thereby damaging the bearings. It also prevents heavier motors from being bounced up and down and having the shaft put flat spots on the drive-end bearings.
- C. The transportation of all large horsepower motors (100 HP and up) should be with a shaft lock device securely in place. This shaft lock will further prevent the bearings from being damaged in transit. It is imperative that motors being transported and brought into the country have this shaft lock device on large horsepower motors 100 HP and up to secure and protect the bearings during ocean freight transit, rail car transit and, subsequently, LTL motor freight to the motor distributor and the motor distributor's customer.
- D. All motors in transit should be lifted only by the eyebolt(s) provided on the motor. Large horsepower motors, when more than one eyebolt is provided, should be lifted by securing the lifting device around all eyebolts.
- E. Store motors in a dry atmosphere (even temperature) which should be free of dirt, dust and airborne particles.
- F. Rotate the shafts on warehoused motors every sixty (60) days to prevent bearing grease from hardening which causes overheating during motor operation and subsequent bearing failure.
- G. Warehoused motors should have the bearing grease in them purged and replaced every six (6) months.

SECTION II:

Mounting – Foundation – Base

- A. When mounting a motor into its application, it is imperative that the motor must be level! Level devices should be used to insure the motor base being level on all four points (feet/bolt holes) and motor shims should be used to insure motor being level on its foundation base.
- B. You should calculate and factor stress on a motor when the motor is running full load when mounting a motor into its foundation. The manufacturer can provide necessary calculations for you depending on the size of the motor and the application for the motor. Please consult on an individual basis. This is especially critical with large horsepower motors 100 HP and up.
- C. The motor mount must be vibration free whether it is a slide base, transition base or a concrete pad. Please have your motor installation expert check the motor mount for potential vibration situations. On large horsepower motors (100 HP and up) it is recommended that foundation studs be used to secure an electric motor as well as the base shims referred to in Section II-A. Please see *FIGURE 1*.

FIGURE 1

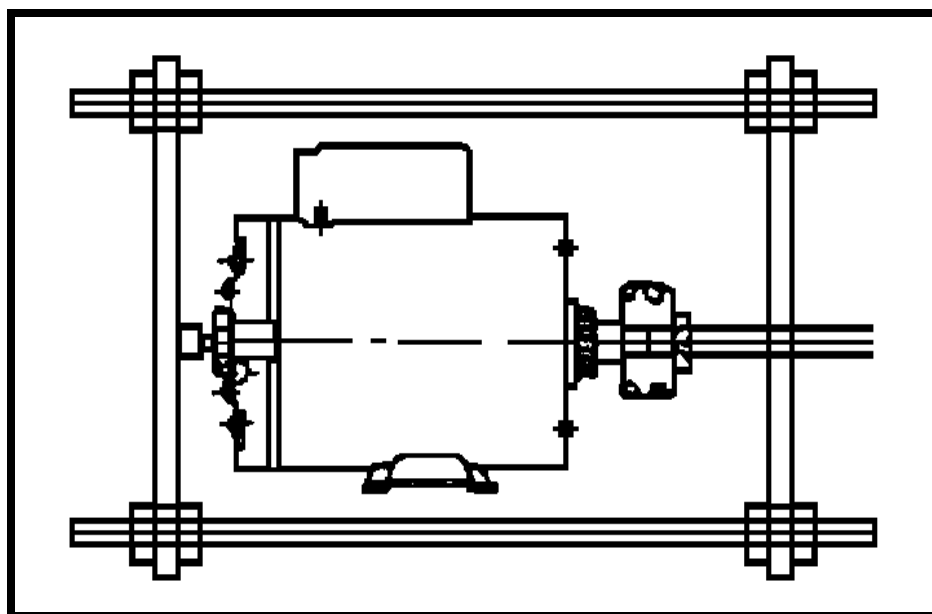

SECTION III: Motor Coupling

- A. All WorldWide Electric Motors are suitable for:
1. Belt drive applications
 2. Direct coupled applications
 3. Flange mount (C and D) applications.
(Motors 404TC/TD and up **MUST** not be mounted horizontally by the flange only, the bases must also be used to support the weight of the motor.)
- B. Check and insure that whether the motor is belted, direct coupled or flange mount that the alignment be true as well as secure. No hammers or any other tools of force should be used when securing the coupling method for an electric motor to its application. Take special care in assuring proper belt tension in large horsepower situations involving belt driven, torque intensive loads. Please see [FIGURE 2](#).
- C. Please consult the manufacturer on sheaves, belts, couplings and flanges before mounting the motor so you know what to look for. Consult your local electric motor expert or call WorldWide Electric at 1-800-808-2131 x 6.
- D. Insist on certified drawings for you motor ensuring that the alignments be correct and that the mounting dimensions be accurate. **Misalignment is the major cause of bearing failure and bearing failure is the major cause of motor failure.**
- E. When there is a choice, direct coupling or flange mounting is preferred by the motor manufacturers as the bearing life on your motor is doubled. Please see [FIGURE 3](#).

FIGURE 2

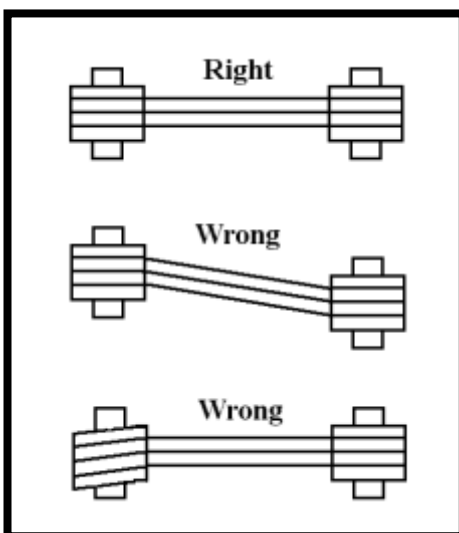
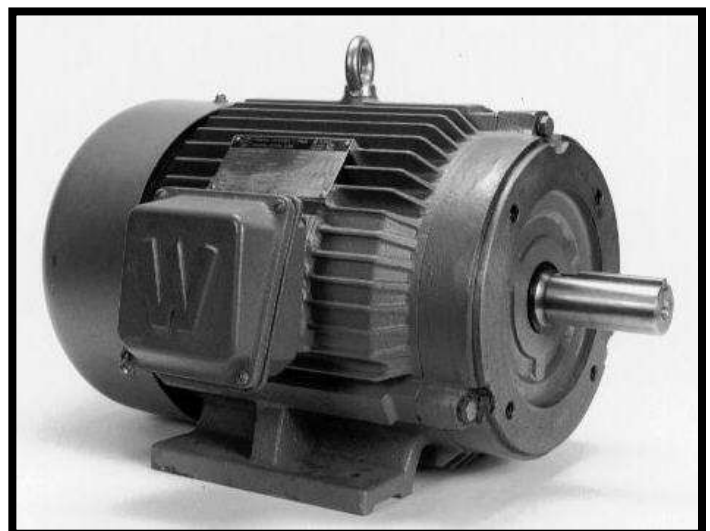

FIGURE 3



SECTION IV:

Proper Running Conditions

- A. Special care should be taken to make sure that the electric motor is mounted at least thirty (30) inches from any wall or structure that would prevent proper ventilation of the electric motor.
- B. Check the area for flammable or combustible materials as well as smoke or dust particles in the air that would contaminate the ventilation process. Air around the motor must be free and clear to flow through the electric motor and allow the fan on the back end of the electric motor to do its job effectively.
- C. If there is a change in altitude that exceeds 3300 feet above sea level, special care must be taken in sizing the electric motor for the application.

ALTITUDE – AMBIENT TEMPERATURE CHART

	Altitude – Meters (Feet) Above Sea Level						
	1000 (3281)	1500 (4921)	2000 (6562)	2500 (8202)	3000 (9842)	3500 (11,483)	4000 (13,123)
Temperature - °C (°F)							
10°C (50°F)							1.50
15°C (59°F)						1.05	0.99
20°C (68°F)					1.05	0.99	0.93
25°C (77°F)				1.05	0.98	0.93	0.88
30°C (86°F)			1.05	0.97	0.92	0.87	0.82
40°C (104°F)	1.00	0.94	0.89	0.85	0.80	0.76	0.72
50°C (122°F)	0.85	0.80	0.76	0.72	0.68	0.65	0.62
60°C (140°F)	0.71	0.67	0.64	0.60	0.57	0.55	0.52

Example: 100 HP @ 60° C At 2000 Meters
 $100 / 0.64 = 156$ HP
(Therefore, You Must Use A 200 HP)

SECTION V: Inspection Before Start-Up

- A. On all large horsepower motors, make sure you **remove the shaft lock** on drive-end shaft.
- B. Turn the shaft by hand and make sure the shaft turns freely. Listen for any unusual noises or interruption in the shaft turning freely.
- C. Check grease level on both drive-end and opposite drive-end bearings. Make sure the bearing cavities are filled with grease to their proper running level. Even in a new motor, grease can evaporate over a period of time and/or harden should the motor have sat on the shelf and the drive-end and opposite drive-end bearings were left unattended.
- D. Perform a final check on the coupling, belt drive set-up and/or mounting bolts on C or D flanges.
- E. Check the wiring diagram and the wiring hook-ups in both the motor junction box and the starter box. Make sure they are in accordance with the diagram on the motor nameplate. Please see **FIGURE 4**. Please also make sure that these connections are tightened down properly.
- F. Consult the motor performance data sheet for the electric motor so that you know what the locked rotor amps will be once the motor is started. Please see sample performance data sheet provided - **FIGURE 5**.
- G. **Make sure the motor is grounded!** Use the grounding lug provided. These grounding lugs are normally provided at the motor terminal box or on one of the mounting feet.

FIGURE 4 - MOTOR NAMEPLATE



		INDUSTRIAL ELECTRIC MOTOR		200895	
		CC006A ISO9001		EPACT RATED 3 PHASE	
Model			Ser No.		
HP	Encl	TEFC	IP	54	FR
Voltage	230/480		Hz	60	
AMPS			RPM		
S.F.	1.15	Design	B	Ins Cl	F
Nar.Eff.	FL		%	3/4	Rating
DE Brng			ODE Brng		
Power Factor			Date Code		
Usable on 208V network at			AMPS		
<input type="checkbox"/> Made in China			WorldWide Electric Corporation		
			<div style="display: flex; flex-direction: column; align-items: center;"> <div style="margin-bottom: 5px;">Low Voltage</div> <div style="display: flex; gap: 10px;"> ⊕⊕⊕ </div> <div style="display: flex; gap: 10px;"> ⊖⊖⊖ </div> <div style="display: flex; gap: 10px;"> L1L2L3 </div> </div>		
			<div style="display: flex; flex-direction: column; align-items: center;"> <div style="margin-bottom: 5px;">High Voltage</div> <div style="display: flex; gap: 10px;"> ⊕⊕⊕ </div> <div style="display: flex; gap: 10px;"> ⊖⊖⊖ </div> <div style="display: flex; gap: 10px;"> L1L2L3 </div> </div>		

FIGURE 5 – PERFORMANCE DATA SHEET







	WWE100-18-405T	
HP	100	
RPM / POLES	1800 / 4	
VOLTAGE PHASE	208 - 230 / 460 V 3	
FRAME	405T	
FREQUENCY	60 HZ	
RATED SPEED	1785 RPM	
FULL LOAD AMPS	230 / 115 A	
DUTY CYCLE	CONTINUOUS	
SERVICE FACTOR	1.15	
AMBIENT TEMP.	40° C	
ALTITUDE	3300 FT.	
INSULATION CLASS	F	
TEMP. RISE @ FULL LOAD	80° C	
DESIGN	B	
RATED TORQUE	296 LB. FT.	
LOCKED ROTOR TORQUE	200%	
BREAKDOWN TORQUE	290%	
LOCKED ROTOR AMPS (STARTING)	1450 / 725 A	
IL / IN	6.3 CODE G	
INRUSH CURRENT	4100 / 2050 A	
SLIP	0.83%	
NO LOAD CURRENT	72.0 / 36.0 A	
MAX. TIME LOCKED ROTOR (HOT)	15 SECONDS	
DE BEARING	NU316	
ODE BEARING	6313	
REGREASING INT-DE	3,000 HOURS (1.22 OZ.)	
REGREASING INT-ODE	6,500 HOURS (0.86 OZ.)	
ENCLOSURE	TEFC (IP54)	
MOUNTING	F-1	
ROTATION	CW / CCW	
MOMENT OF INERTIA	9.200 LB. FT. SQUARED	
C FLANGE	W400TC	
D FLANGE	W400TD	
CONNECTION DIAGRAM	230 / 460 V - 12 LEAD Y/Delta	
SHAFT MATERIAL	1045 CARBON STEEL	
APPROX. WEIGHT	1350 LBS.	
LOAD	POWER FACTOR	EFFICIENCY (%)
100%	0.87	94.5
75%	0.86	94.8
50%	0.80	92.9
   		
REVISED 06/10/04		

FIGURE 6 – DIMENSIONAL DRAWING



SECTION VI:**Starting Systems**

- A. Frames 143T through 184T are 9-Lead, 208-230/460 Volt, Wye wound.
- B. Frames 213T through 256T are 9-Lead, 208-230/460 Volt, Delta wound.
- C. Frames 284T through 447T and 505UZ are 12-Lead, 208-230/460 Volt, Wye/Delta wound.
- D. Frames 449T and 586/7 are 6-Lead, 460 Volt, Wye-Delta wound.
- E. Please see wiring terminal samples provided – [FIGURE 7](#).

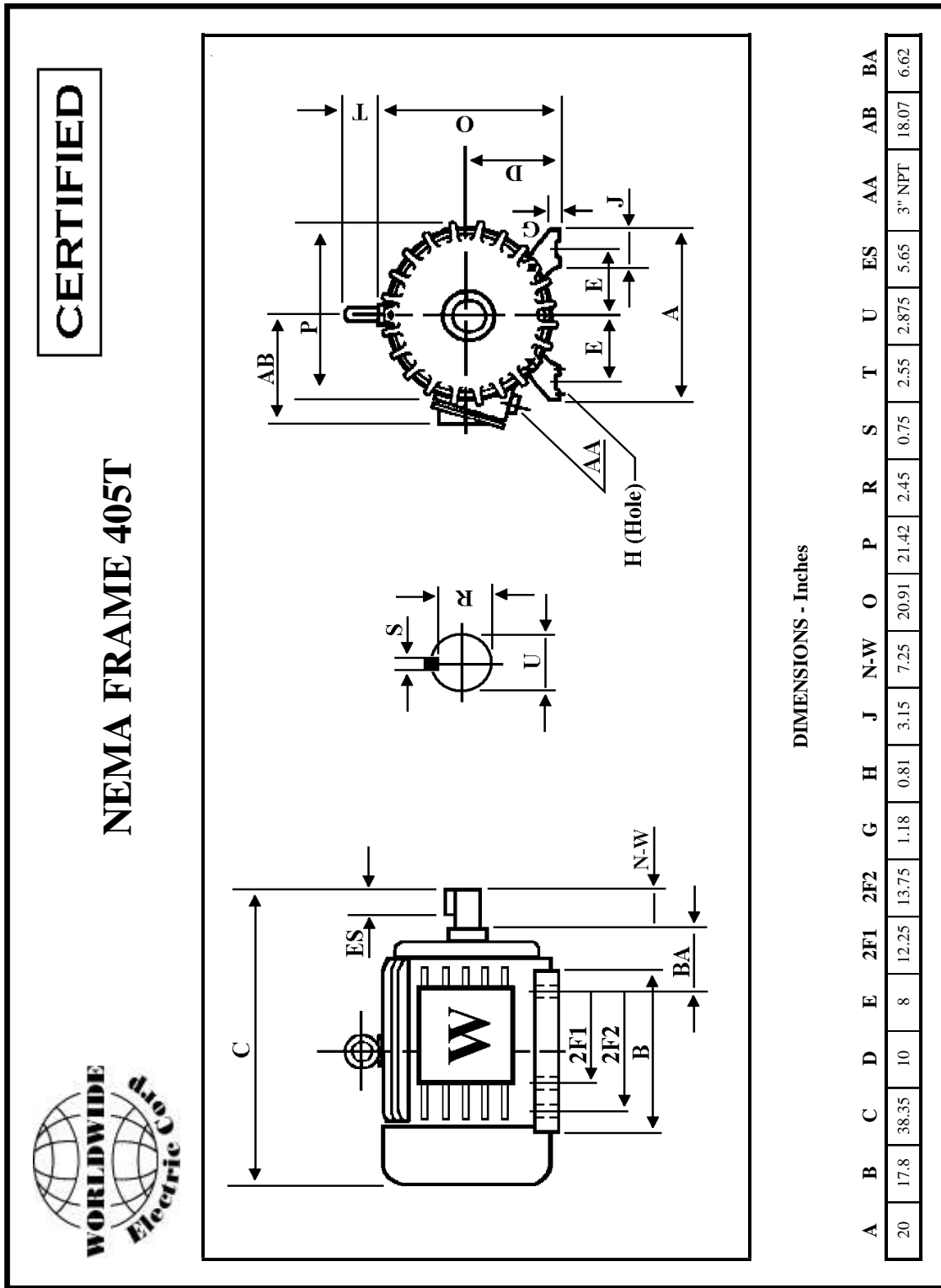
FIGURE 7 – WIRING TERMINAL SAMPLES

9-Lead, 208-230/460 Volt

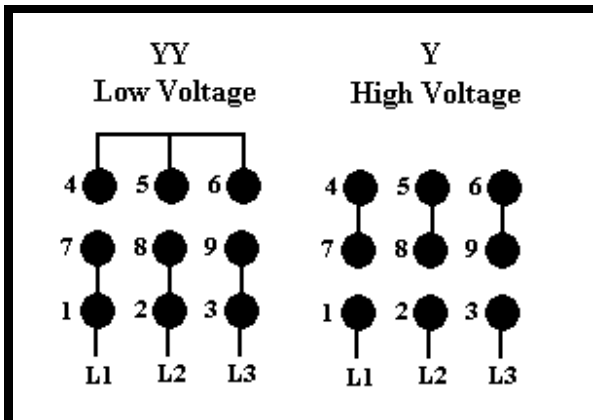

9-Lead, 208-230/460 Volt

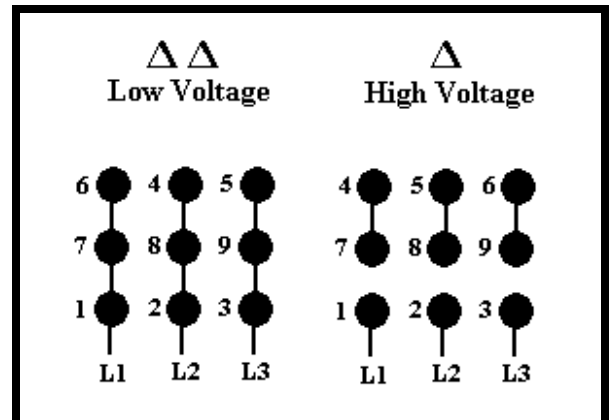

12-Lead, 208-230/460 Volt

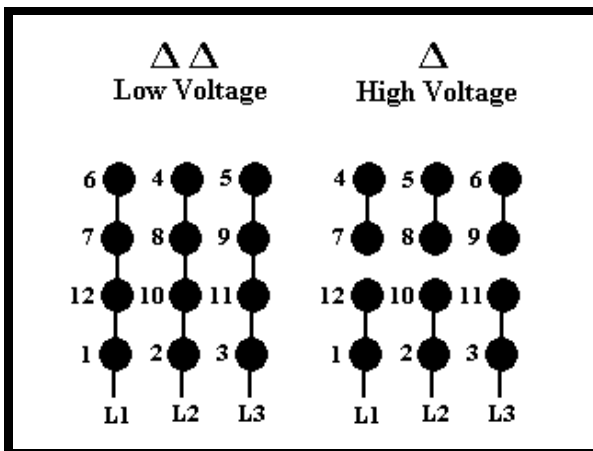

6-Lead, 460 Volt

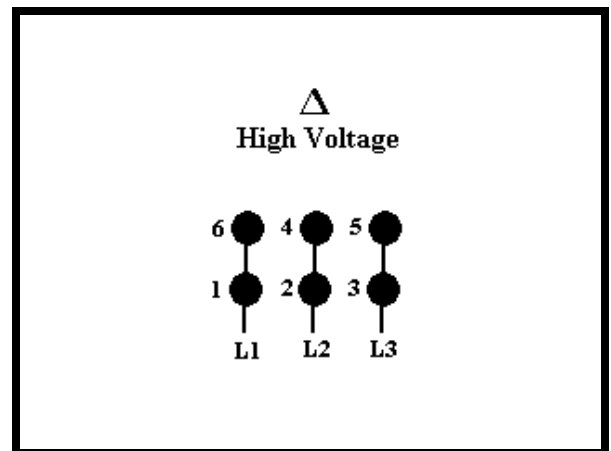

LEAD WIRE INFORMATION (B, S & M Factories)

Frame Size	WWE		WWES		WWEM	
	Lead Size	Lead Length	Lead Size	Lead Length	Lead Size	Lead Length
143T	16 AWG	9-1/2"	16 AWG	9-1/2"	16 AWG	9-1/2"
145T	16 AWG	9-1/2"	16 AWG	9-1/2"	16 AWG	9-1/2"
182T	16 AWG	9-1/2"	16 AWG	9-1/2"	16 AWG	9-1/2"
184T	16 AWG	9-1/2"	16 AWG	9-1/2"	16 AWG	9-1/2"
213T	16 AWG	9-1/2"	16 AWG	9-1/2"	16 AWG	9-1/2"
215T	14 AWG	9-1/2"	14 AWG	9-1/2"	14 AWG	9-1/2"
254T	12 AWG	9-1/2"	12 AWG	9-1/2"	12 AWG	9-1/2"
256T	12 AWG	9-1/2"	12 AWG	9-1/2"	12 AWG	9-1/2"
284T	10 AWG	10-5/8"	10 AWG	10-5/8"	10 AWG	9-1/2"
286T	10 AWG	10-5/8"	10 AWG	10-5/8"	10 AWG	9-1/2"
324T	8 AWG	13"	8 AWG	13"	8 AWG	9-1/2"
326T	8 AWG	13"	8 AWG	13"	8 AWG	9-1/2"
364T	6 AWG	13"	6 AWG	13"	6 AWG	11"
365T	6 AWG	13"	6 AWG	13"	6 AWG	11"
404T	4 AWG	13-3/4"	4 AWG	13-3/4"	4 AWG	11"
405T	4 AWG	13-3/4"	4 AWG	13-3/4"	4 AWG	11"
444T	3 AWG	13-3/4"	3 AWG	13-3/4"	N/A	N/A
445T	3 AWG	13-3/4"	3 AWG	13-3/4"	N/A	N/A
445/7T	3 AWG	13-3/4"	3 AWG	13-3/4"	N/A	N/A
449T	WWE200-12 – 2 AWG	14"	1 AWG	14"	N/A	N/A
505Z (UZ)	WWE250-18 – 1 AWG	14"	N/A	N/A	N/A	N/A
586/7 (UZ)	1/0 AWG	14"	1/0 AWG	13"	N/A	N/A

SECTION VII:

Initial Motor Start-Up

- A. Monitor the start-up, the voltage and the running voltage on the motor. Please see **FIGURE 8** for allowable starts and starting intervals. The full load voltage should not exceed the line voltage on the motor nameplate multiplied by the service factor of the motor. Ex.: $230 \text{ Volt} \times 1.15 = 264.5$.
- B. Pay special attention to the temperature readings on the motor. The outside temperature or skin temperature of the motor as well as monitoring and measuring the inside temperature of the motor. Also note that the bearing temperature should not exceed 60°C .
- C. Check the full load running amperage on the motor to ensure it is at or very close to the full load amps listed on the performance data sheet.
- D. Listen for any unusual noises on start-up and in the initial first hour of the motor running. Listen especially to the bearings on both the drive-end and opposite drive-end. Please note, with large horsepower motors that have roller bearings on the drive-end of the motor, these bearings will run noisier (initial bearing chatter) in the initial running stages of the motor. It is normal for roller bearings to run somewhat noisier than ball bearing motors.
- E. Abnormal initial bearing noise could possibly be a defective bearing with a flat spot in it or it could simply be bearings that do not have enough grease in them. If there is abnormal noise, please shut the motor down and re-check the grease levels on both drive-end and opposite drive-end bearings.



Initial Start-Up

**FIGURE 8 – ALLOWABLE STARTS AND STARTING INTERVALS
(Design A and B Motors)**

HP	3600 RPM		1800 RPM		1200 RPM	
	A	C	A	C	A	C
1	15	75	30	38	34	33
1.5	12.9	76	25.7	38	29.1	34
2	11.5	77	23	39	26.1	35
3	9.9	80	19.8	40	22.4	36
5	8.1	83	16.3	42	18.4	37
7.5	7.0	88	13.9	44	15.8	39
10	6.2	92	12.5	46	14.2	41
15	5.4	100	10.7	50	12.1	44
20	4.8	110	9.6	55	10.9	48
25	4.4	115	8.8	58	10.0	51
30	4.1	120	8.2	60	9.3	53
40	3.7	130	7.4	65	8.4	57
50	3.4	145	6.8	72	7.7	64
60	3.2	170	6.3	85	7.2	75
75	2.9	180	5.8	90	6.6	79
100	2.6	220	5.2	110	5.9	97
125	2.4	275	4.8	140	5.4	120
150	2.2	320	4.5	160	5.1	140
200	2.0	600	4.0	300	4.5	265
250	1.8	1000	3.7	500	4.2	440

A = Maximum number of starts per hour.

C = Minimum rest or off time in seconds between starts.

SECTION VIII: Preventative Ongoing Maintenance

- A. Exterior cleaning – wipe down all motors with a soft cloth and, whenever possible, use compressed air to hose the motor housing, in between the cooling ribs and at the fan and fan cover sections.
- B. Follow the bearing lubrication schedule provided by the manufacturer! 95% of all motor problems are bearing problems. Please see **FIGURE 9** for relubrication intervals and the lubrication schedule – **FIGURE 10**.
- C. Monitor the bearing temperature on the motor, especially the drive-end bearing, to ensure it does not exceed 60°C.
- D. Whenever possible, have the insulation checked periodically by an authorized motor specialist.
- E. Whenever possible, follow a bearing maintenance program of purging the grease completely through the bearings every six months and replacing the bearings when the recommended L-10 life (in running hours) expires. WorldWide Electric Motors have SKF premium quality bearings. The L-10 life of these bearings are as follows:
 - 1. Belt drive applications – 50,000 hours
 - 2. Direct coupled applications – 100,000 hours

FIGURE 9 – RELUBRICATION INTERVALS

Type Of Service	Typical Examples	HP Range	Relubrication Interval	
			Horizontal	Vertical
Easy	Valves, Door Openers, Portable Floor Sanders, Motor Operating Infrequently (One Hour Per Day)	1.0 – 7.5 10 – 40 50 – 150 200 – 350 400 – 500	10 Years 7 Years 4 Years 3 Years 1 Year	9 Years 3 Years 1.5 Years 9 Months ---
Standard	Machine Tools, Air Conditioning Apparatus, Conveyors, One Or Two Shifts, Garage Compressors, Refrigeration Machinery, Laundry Machinery, Oil Well Pumps, Water Pumps, Wood Working Machinery	1.0 – 7.5 10 – 40 50 – 150 200 – 350 400 – 500	7 Years 4 Years 1.5 Years 1 Year 6 Months	3 Years 1 Year 6 Months 3 Months ---
Severe	Motor For Fans, M-G Sets, etc... That Run 24 Hours Per Day, 365 Days Per Year, Coal and Mining Machinery, Motors Subject To Severe Vibration, Steel Mill Machinery	1.0 – 7.5 10 – 40 50 – 150 200 – 350 400 – 500	4 Years 1.5 Years 9 Months 6 Months 3 Months	1.5 Years 6 Months 3 Months 1.5 Months ---
Very Severe	Dirty, Vibrating Applications Where End Of Shaft Is Hot (Pumps and Fans), High Ambient Temperatures	1.0 – 7.5 10 – 40 50 – 150 200 – 350 400 – 500	9 Months 4 Months 4 Months 3 Months 2 Months	6 Months 3 Months 2 Months 1 Month ---

FIGURE 10 – LUBRICATION SCHEDULE (IN HOURS)

HP	3600 RPM				1800 RPM				1200 RPM				900 RPM			
	DE Bearing	Grease Amount (Oz.)*	ODE Bearing	Grease Amount (Oz.)*	DE Bearing	Grease Amount (Oz.)*	ODE Bearing	Grease Amount (Oz.)*	DE Bearing	Grease Amount (Oz.)*	ODE Bearing	Grease Amount (Oz.)*	DE Bearing	Grease Amount (Oz.)*	ODE Bearing	Grease Amount (Oz.)*
1	N/A	N/A	N/A	N/A	N/A	N/A	N/A	N/A	N/A	N/A	N/A	N/A	N/A	N/A	N/A	N/A
1.5	N/A	N/A	N/A	N/A	N/A	N/A	N/A	N/A	N/A	N/A	N/A	N/A	N/A	N/A	N/A	N/A
2	N/A	N/A	N/A	N/A	N/A	N/A	N/A	N/A	N/A	N/A	N/A	N/A	N/A	N/A	N/A	N/A
3	N/A	N/A	N/A	N/A	N/A	N/A	N/A	N/A	N/A	N/A	N/A	N/A	N/A	N/A	N/A	N/A
5	N/A	N/A	N/A	N/A	N/A	N/A	N/A	N/A	N/A	N/A	N/A	N/A	12400	0.46	12700	0.29
7.5	N/A	N/A	N/A	N/A	N/A	N/A	N/A	N/A	13400	0.46	13400	0.29	12400	0.46	12700	0.29
10	N/A	N/A	N/A	N/A	N/A	N/A	N/A	N/A	13400	0.46	13400	0.29	12700	0.64	13400	0.46
15	3500	0.46	3500	0.29	9000	0.46	9000	0.29	12400	0.64	13400	0.46	12700	0.64	13400	0.46
20	3500	0.46	3500	0.29	9000	0.46	9000	0.29	12400	0.64	13400	0.46	12400	0.75	12700	0.64
25	3200	0.64	3500	0.46	7500	0.64	9000	0.46	12400	0.75	12700	0.64	12400	0.75	12700	0.64
30	3200	0.64	3500	0.46	7500	0.64	9000	0.46	12200	0.75	12400	0.64	12200	0.86	12400	0.75
40	3200	0.75	3200	0.64	7000	0.75	7500	0.64	12200	0.86	12400	0.75	12200	0.86	12400	0.75
50	3200	0.75	3200	0.64	7000	0.75	7500	0.64	12200	0.86	12400	0.75	4400	1.22	12200	0.86
60	2800	0.86	3200	0.75	6500	0.86	7000	0.75	3000	1.22	11000	0.86	4400	1.22	12200	0.86
75	2800	0.86	3200	0.75	6500	0.86	7000	0.75	3000	1.22	11000	0.86	4300	1.47	12200	0.86
100	2800	1.22	2800	0.86	2200	1.22	6500	0.86	4300	1.47	11000	0.86	4300	1.47	12200	0.86
125	2800	1.47	2800	0.86	2500	1.47	6500	0.86	4300	1.47	11000	0.86	4100	1.61	12200	0.86
150	2800	1.47	2800	0.86	2500	1.47	6500	0.86	4100	1.61	11000	0.86	4000	1.82	12000	1.61
200	2800	1.61	2800	0.86	2200	1.61	6500	0.86	3500	1.82	3800	1.61	4000	1.82	12000	1.61
									3250	2.14	3800	1.61				
250	2300	1.82	2800	1.82	2100	1.82	2300	1.61	3500	1.82	3800	1.61	2800	2.14	3050	2.14
					1900	2.14	2300	1.61	2800	2.14	3050	2.14				
300	N/A	N/A	N/A	N/A	2100	1.82	2300	1.61	3500	1.82	3800	1.61	4000	2.14	12000	2.14
					1500	2.14	1700	2.14	2800	2.14	3050	2.14				
350	N/A	N/A	N/A	N/A	1500	2.14	1700	2.14	2800	2.14	3050	2.14	N/A	N/A	N/A	N/A
400	N/A	N/A	N/A	N/A	1500	2.14	1700	2.14	2800	2.14	3050	2.14	N/A	N/A	N/A	N/A
450	N/A	N/A	N/A	N/A	1500	2.14	1700	2.14	2800	2.14	3050	2.14	N/A	N/A	N/A	N/A
500	N/A	N/A	N/A	N/A	1500	2.14	1700	2.14	2800	2.14	3050	2.14	N/A	N/A	N/A	N/A

*** Only Exxon POLYREX[®] EM Polyurea Grease Should Be Used**



SECTION IX:

Warranty Policy

A. Warranty Length

The warranty length for WorldWide Electric Motors is as follows:

Fractional HP Motors

General Purpose Motors	Two (2) years from date of sale (invoice)
Stainless Steel / Washdown Duty Motors	One (1) year from date of sale (invoice)
Jet Pump Motors	Two (2) years from date of sale (invoice)
Resilient (Cradle) Base Motors	Two (2) years from date of sale (invoice)
Compressor Duty Motors	Two (2) years from date of sale (invoice)
Permanent Magnet DC Motors	One (1) year from date of sale (invoice)

EISA-Compliant Motors Two (2) years from date of sale (invoice)

Premium Efficiency Motors Two (2) years from date of sale (invoice)

Explosion Proof Motors Two (2) years from date of sale (invoice)

Advanced Design Rock Crusher Motors Two (2) years from date of sale (invoice)

Shaker Screen Motors Two (2) years from date of sale (invoice)

Close-Coupled Pump Motors Two (2) years from date of sale (invoice)

Oil Well Pump Motors Two (2) years from date of sale (invoice)

Vertical Hollow Shaft Motors One (1) year from date of sale (invoice)

Motor Slide Bases Three (3) years from date of sale (invoice)

Hyundai Premium Efficiency Motors Three (3) years from date of sale (invoice)

SECTION IX:

Warranty Policy

B. Procedure

All WorldWide Electric Motors with the exception of Explosion Proof Motors and Vertical Hollow Shaft Motors:

1. Motors up to and including 40 HP are covered by our no-fault policy. If the motor has failed within the warranty period, the nameplate must be mailed to WorldWide Electric for credit (photo of nameplate required for stainless steel / washdown duty motors).
2. Motors 50 HP and above must be inspected by an authorized EASA service center or other approved motor shop for determination of cause of failure. Authorized EASA service centers are available inside and outside of the United States. Visit the EASA website at www.easa.com to find the nearest authorized service center. These shops may also be able to assist with non-warranty service.
3. The service center must provide a written estimate for inspection and a purchase order must be issued by WorldWide Electric prior to the motor inspection.
4. If the failure is determined to be from a defect in material or workmanship when operated under normal conditions and in accordance with nameplate characteristic limits, WorldWide Electric shall either repair or replace the motor. The service center must provide a written estimate for repair and a purchase order must be issued by WorldWide Electric prior to the repair being performed.

Explosion Proof Motors and Vertical Hollow Shaft Motors:

1. Motors must be inspected by a UL certified / authorized EASA service center for determination of cause of failure. Authorized EASA service centers are available inside and outside of the United States. Visit the EASA website at www.easa.com to find the nearest authorized service center. These shops may also be able to assist with non-warranty service.
2. The service center must provide a written estimate for inspection and a purchase order must be issued by WorldWide Electric prior to the motor inspection.
3. If the failure is determined to be from a defect in material or workmanship when operated under normal conditions and in accordance with nameplate characteristic limits, WorldWide Electric shall either repair or replace the motor. The service center must provide a written estimate for repair and a purchase order must be issued by WorldWide Electric prior to the repair being performed.

SECTION X: Bearing Size Chart

- A. WorldWide Electric uses SKF bearings. SKF is recognized as the premier bearing in the electric motor market.
- B. A bearing chart is provided for your convenience. The bearing sizes also appear on the motor nameplate.

BEARING SIZE CHART (B, S & M Factories)

Frame Size	DE Bearing			ODE Bearing				
	WWE	WWES	WWEM	WWE	WWES	WWEM		
143T	6205-ZZ	6205-ZZ	6205-ZZ	6205-ZZ	6205-ZZ	6205-ZZ		
145T	6205-ZZ	6205-ZZ	6205-ZZ	6205-ZZ	6205-ZZ	6205-ZZ		
182T	6306-ZZ	6306-ZZ	6306-ZZ	6306-ZZ	6306-ZZ	6306-ZZ		
184T	6306-ZZ	6306-ZZ	6306-ZZ	6306-ZZ	6306-ZZ	6306-ZZ		
213T	6308-ZZ	6308-ZZ	6308-ZZ	6308-ZZ	6308-ZZ	6306-ZZ		
215T	6308-ZZ	6308-ZZ	6308-ZZ	6308-ZZ	6308-ZZ	6306-ZZ		
254T	6309	6309	6309	6209	6309	6308		
256T	6309	6309	6309	6209	6309	6308		
284T	6311	6311	6311	6309	6311	6309		
286T	6311	6311	6311	6309	6311	6309		
324T	6312	6312	6312	6311	6312	6312		
326T	6312	6312	6312	6311	6312	6312		
364T	6313	6313	6313	6312	6313	6312		
365T	6313	6313	6313	6312	6313	6312		
404T	NU316	NU316	NU316	6313	6314	6313		
405T (4,6,8P)	NU316	405T (4, 6P)	NU316	NU316	6313	405T (4, 6P)	6314	6313
405T (2P)	6313	405T (2P)	6314	6313		405T (2P)	6314	6313
444T (4,6,8P)	NU318	444T (4, 6P)	NU319	N/A	6313	444T (4, 6P)	6313	N/A
444T (2P)	6313	444T (2P)	6317	N/A		444T (2P)	6313	N/A
445T (4,6,8P)	NU318	445T (4, 6P)	NU319	N/A	6313	445T (4, 6P)	6313	N/A
445T (2P)	6313	445T (2P)	6317	N/A		445T (2P)	6313	N/A
445/7T (4,6,8P)	NU319	447T (4, 6P)	NU319	N/A	6313	447T (4, 6P)	6313	N/A
445/7T (2P)	6313	447T (2P)	6317	N/A		447T (2P)	6313	N/A
449T (4,6,8P)	NU320	NU320	N/A	6320	6320	6320	N/A	
449TS (4,6,8P)	6320							
449TS (2P)	6314							
505Z (UZ)	NU322	N/A	N/A	6319	N/A	N/A	N/A	
586/7 (UZ)	NU326	NU326	N/A	6324	6324	N/A	N/A	

SECTION XI:**Shipping Crate Dimensions / Weights**

Shipping crate dimensions / weights have been provided for those customers who reship and, at times, export electric motors in the crate as is.

SHIPPING CRATE DIMENSIONS / WEIGHTS (B Factory)

HP	3600 RPM		1800 RPM		1200 RPM		900 RPM	
	Weight (Lbs.)	L x W x H (Inches)	Weight (Lbs.)	L x W x H (Inches)	Weight (Lbs.)	L x W x H (Inches)	Weight (Lbs.)	L x W x H (Inches)
1	N/A	N/A	58	14x11x17	65	14x11x17	N/A	N/A
1.5	50	14x11x17	60	14x11x17	100	16x14x20	N/A	N/A
2	60	14x11x17	70	14x11x17	105	16x14x20	N/A	N/A
3	100	16x14x20	90	16x14x20	155	18x16x25	N/A	N/A
5	110	16x14x20	110	16x14x20	175	18x16x25	240	31x23x22
7.5	155	18x16x25	160	18x16x25	300	31x23x22	280	31x23x22
10	181	18x16x25	180	18x16x25	340	31x23x22	350	33x24x24
15	260	31x23x22	325	31x23x22	410	33x24x24	396	33x24x24
20	331	31x23x22	370	31x23x22	440	33x24x24	504	36x26x25
25	381	33x24x24	420	33x24x24	580	36x26x25	572	36x26x25
30	480	33x24x24	470	33x24x24	610	36x26x25	711	39x28x27
40	590	36x26x25	590	36x26x25	650	39x28x27	754	39x28x27
50	620	36x26x25	650	36x26x25	680	39x28x27	1033	44x32x30
60	675	39x28x27	780	39x28x27	1035	44x32x30	1183	44x32x30
75	857	39x28x27	870	39x28x27	1100	44x32x30	1378	47x33x32
100	1121	44x32x30	1350	44x32x30	1970	47x33x32	1473	47x33x32
125	1250	47x33x32	1500	47x33x32	2100	47x33x32	1798	47x33x32
150	1500	47x33x32	1630	47x33x32	2200	47x33x32	2520	63x33x37
200	1800	47x33x32	1858	47x33x32	449T - 2508	63x33x37	2900	63x33x37
					505UZ - 2469	59x36x42		
250	2305	63x33x37	449T - 2508	63x33x37	449T - 2750	63x33x37	4030	72x44x48
			505UZ - 2360	59x36x42	586/7 - 3696	72x44x48	4440	72x44x48
300	N/A	N/A	449T - 2728	63x33x37	449T - 2830	63x33x37	N/A	N/A
			586/7 - 3784	72x44x48	586/7 - 4136	72x44x48	N/A	N/A
350	N/A	N/A	3968	72x44x48	4145	72x44x48	N/A	N/A
400	N/A	N/A	4101	72x44x48	4409	72x44x48	N/A	N/A
450	N/A	N/A	4500	72x44x48	4500	72x44x48	N/A	N/A
500	N/A	N/A	4630	72x44x48	4740	72x44x48	N/A	N/A

SHIPPING CRATE DIMENSIONS / WEIGHTS (S Factory)

HP	3600 RPM		1800 RPM		1200 RPM	
	Weight (Lbs.)	L x W x H (Inches)	Weight (Lbs.)	L x W x H (Inches)	Weight (Lbs.)	L x W x H (Inches)
1	N/A	N/A	64	12x17x12	70	12x17x12
1.5	66	12x17x12	68	12x17x12	113	15x19x15
2	72	12x17x12	75	12x17x12	140	15x19x15
3	120	15x19x15	123	15x19x15	150	23x16x17
5	148	15x19x15	152	15x19x15	174	23x16x17
7.5	159	23x16x17	163	23x16x17	257	28x21x23
10	178	23x16x17	194	23x16x17	292	28x21x23
15	282	28x21x23	297	28x21x23	383	31x23x24
20	319	28x21x23	337	30x21x23	425	33x23x24
25	394	31x23x24	416	31x23x24	524	36x25x26
30	425	31x23x24	449	33x23x24	537	36x25x26
40	557	36x25x26	584	36x25x26	729	39x27x27
50	593	36x25x26	623	36x25x26	768	39x27x27
60	742	39x27x27	733	39x27x27	1018	45x32x30
75	764	39x27x27	808	39x27x27	1068	45x32x30
100	952	45x32x30	1062	45x32x30	1476	52x34x33
125	1420	52x34x33	1557	52x34x33	1865	52x34x33
150	1579	52x34x33	1780	52x34x33	N/A	N/A
200	1619	52x34x33	2055	52x34x33	N/A	N/A
250	N/A	N/A	N/A	N/A	N/A	N/A
300	N/A	N/A	N/A	N/A	N/A	N/A
350	N/A	N/A	N/A	N/A	N/A	N/A
400	N/A	N/A	N/A	N/A	N/A	N/A
450	N/A	N/A	N/A	N/A	N/A	N/A
500	N/A	N/A	N/A	N/A	N/A	N/A

SHIPPING CRATE DIMENSIONS / WEIGHTS (M Factory)

HP	3600 RPM		1800 RPM		1200 RPM	
	Weight (Lbs.)	L x W x H (Inches)	Weight (Lbs.)	L x W x H (Inches)	Weight (Lbs.)	L x W x H (Inches)
1	N/A	N/A	64	17x12x10	70	17x12x10
1.5	66	17x12x10	68	17x12x10	113	19x13x15
2	72	17x12x10	75	17x12x10	140	19x13x15
3	120	19x13x15	123	19x13x15	150	24x17x17
5	148	19x13x15	152	19x13x15	174	24x17x17
7.5	159	24x17x17	163	24x17x17	257	29x21x19
10	178	24x17x17	194	24x17x17	292	29x21x19
15	282	29x21x19	297	29x21x19	383	30x22x21
20	319	29x21x19	337	29x21x19	425	30x22x21
25	394	30x22x21	416	30x22x21	524	34x24x25
30	425	30x22x21	449	30x22x21	537	34x24x25
40	557	34x24x25	584	34x24x25	729	37x28x28
50	593	34x24x25	623	34x24x25	768	37x28x28
60	742	37x28x28	733	37x28x28	1018	40x32x32
75	764	37x28x28	808	37x28x28	1068	40x32x32
100	952	40x32x32	1062	40x32x32	1476	N/A

SECTION XII: Double-Punched Motors

Many WorldWide Electric Motors have double-punched frames featuring the next smaller sized frame as well as the standard NEMA sized frame listed for that horsepower and RPM.

DOUBLE PUNCHED MOTORS (B, S & M Factories)

Frame Size	WWE		WWES		WWEM	
	Double Punched	Punched For	Double Punched	Punched For	Double Punched	Punched For
143T	NO		NO		NO	
145T	YES	143T	YES	143T	YES	143T
182T	NO		YES	184T	NO	
184T	YES	182T	YES	182T	YES	182T
213T	NO		NO		NO	
215T	YES	213T	YES	213T	YES	213T
254T	NO		NO		NO	
256T	YES	254T	YES	254T	YES	254T
284T	NO		NO		NO	
286T	YES	284T	YES	284T	YES	284T
324T	NO		YES	326T	NO	
326T	YES	324T	YES	324T	YES	324T
364T	NO		NO		NO	
365T	YES	364T	YES	364T	YES	364T
404T	NO		YES	405T	YES	405T
405T	YES	404T	YES	404T	YES	404T
444T	NO		NO		N/A	N/A
445T	YES	444T	YES	444T	N/A	N/A
445/7T	YES	445T	YES	445T	N/A	N/A
449T	NO		NO		N/A	N/A
505UZ	YES	504T	N/A	N/A	N/A	N/A
586/7	YES	586	YES	586	N/A	N/A

SECTION XIII: F1 / F2 Mounting

F1 / F2 MOUNTING (B, S & M Factories)

HP	Ability To Be Modified From F1 To F2 Mount									
	WWE				WWES			WWEM		
	3600 RPM	1800 RPM	1200 RPM	900 RPM	3600 RPM	1800 RPM	1200 RPM	3600 RPM	1800 RPM	1200 RPM
1	N/A	YES	YES	N/A	N/A	YES	YES	YES	YES	YES
1.5	YES	YES	YES	N/A	YES	YES	YES	YES	YES	YES
2	YES	YES	YES	N/A	YES	YES	YES	YES	YES	YES
3	YES	YES	YES	N/A	YES	YES	YES	YES	YES	YES
5	YES	YES	YES	YES	YES	YES	YES	YES	YES	YES
7.5	YES	YES	YES	YES	YES	YES	YES	YES	YES	YES
10	YES	YES	YES	YES	YES	YES	YES	YES	YES	YES
15	YES	YES	YES	YES	YES	YES	YES	YES	YES	YES
20	YES	YES	YES	YES	YES	YES	YES	YES	YES	YES
25	NO	NO	YES	YES	YES	YES	YES	YES	YES	YES
30	NO	NO	YES	YES	YES	YES	YES	YES	YES	YES
40	NO	NO	YES	YES	YES	YES	YES	YES	YES	YES
50	NO	NO	YES	YES	YES	YES	YES	YES	YES	YES
60	NO	NO	YES	YES	YES	YES	YES	YES	YES	YES
75	NO	NO	YES	YES	YES	YES	YES	YES	YES	YES
100	NO	NO	YES	YES	YES	YES	YES	YES	YES	YES
125	YES	YES	YES	YES	YES	YES	YES	N/A	N/A	N/A
150	YES	YES	YES	NO	YES	YES	YES	N/A	N/A	N/A
200	YES	YES	449T - NO	NO	YES	YES	NO	N/A	N/A	N/A
			505UZ - NO							
250	NO	449T - NO 505UZ - NO	449T - NO 586/7 - NO	NO	NO	NO	NO	N/A	N/A	N/A
300	N/A	449T - NO 586/7 - NO	449T - NO 586/7 - NO	NO	NO	NO	NO	N/A	N/A	N/A
350	N/A	NO	NO	N/A	NO	NO	NO	N/A	N/A	N/A
400	N/A	NO	NO	N/A	NO	NO	NO	N/A	N/A	N/A
450	N/A	NO	NO	N/A	NO	NO	NO	N/A	N/A	N/A
500	N/A	NO	NO	N/A	NO	NO	NO	N/A	N/A	N/A

SECTION XIV: Conduit Hole Dimensions

Conduit hole dimensions are national pipe thread standard and listed here for your convenience on all motor sizes.

CONDUIT HOLE DIMENSIONS (B, S & M Factories)

Frame Size	WWE	WWES	WWEM
	Taper Thread (NPT)	Taper Thread (NPT)	Taper Thread (NPT)
143T	3/4"	3/4"	3/4"
145T	3/4"	3/4"	3/4"
182T	1"	1"	1"
184T	1"	1"	1"
213T	1"	1"	1"
215T	1"	1"	1"
254T	1.5"	1.5"	1.5"
256T	1.5"	1.5"	1.5"
284T	1.5"	1.5"	1.5"
286T	1.5"	1.5"	1.5"
324T	2"	2"	2"
326T	2"	2"	2"
364T	3"	3"	3"
365T	3"	3"	3"
404T	3"	3"	3"
405T	3"	3"	3"
444T	2 x 3"	2 x 3"	N/A
445T	2 x 3"	2 x 3"	N/A
445/7T	2 x 3"	2 x 3"	N/A
449T	2 x 3"	2 x 3"	N/A
505UZ	2 x 3"	N/A	N/A
586/7	2 x 3"	2 x 3"	N/A

SECTION XV:

Guidelines For VFD Use

- A. All stock three-phase motors (with the exception of explosion proof motors and oil well pump motors) are suitable for variable torque $T=N^2$ applications with a 5:1 speed range as per Item D. and conditional to Item F.
- B. All stock three-phase motors (with the exception of explosion proof motors and oil well pump motors) are suitable for constant torque applications with a 2:1 speed range as per Item D. and conditional to Item F.
- C. Suitability of our stock motors for other speed ranges will be based on an individual application assessment. (Complete with forced air blower systems, derated motors, etc...)
- D. The insulation systems of the motors in Items A and B are suitable to withstand the voltage stress per NEMA Part 30 having the value of:
- | | | |
|-----------------------|---|-------|
| ▶ Base Voltage Rating | ≤ | 600 V |
| ▶ V _{pk} | = | 1 Kv |
| ▶ Rise Time | = | 2 μs |
- E. WorldWide Electric Corporation can supply spike resistant wire on factory ordered motors per NEMA Part 31 having the value of:
- | | | |
|-----------------------|---|--------|
| ▶ Base Voltage Rating | ≤ | 600 V |
| ▶ V _{pk} | = | 1.6 Kv |
| ▶ Rise Time | = | 0.1 μs |
- F. It is the responsibility of the system design engineer to ensure that the system being supplied/installed stays within the above limitations and takes into account the particular nature of a variable frequency drive application as a complete system and not just specific parts of the application.

It has come to our attention and we have seen the evidence that some drives/systems installed exceed even the allowable NEMA standards set for motors under Part 31 (and therefore Part 30) which means that despite the motors being “Definite Purpose Inverter-Fed Motors” Part 31, they would not withstand the voltage stresses imposed by the drive/system. Therefore, by using the correct load filters/reactors it is possible to protect any motor and application, definite purpose or other, from winding damage and/or system damage due to the drive output.

SECTION XVI: Decibel Levels (Sound Levels)

Decibel levels (sound levels) should be measured on motor start-up, after thirty (30) days and after six (6) months. Decibel levels are also an indication as to the vibration levels of an electric motor. A decibel chart has been provided here for your convenience. If the measured motor decibel levels exceed the listed levels by more than ten percent (10%), please consult the motor manufacturer and/or your motor repair center.

DECIBEL LEVELS (B Factory)

HP	Noise Level Lw dB(A)			
	3600 RPM	1800 RPM	1200 RPM	900 RPM
1	N/A	64.0	59.3	N/A
1.5	71.8	68.0	65.0	N/A
2	71.9	68.8	66.5	N/A
3	73.0	74.0	68.0	N/A
5	73.4	73.0	70.8	69.0
7.5	74.1	78.4	73.0	69.0
10	74.4	74.3	74.0	70.0
15	74.8	74.6	75.0	72.0
20	75.0	74.0	76.0	73.0
25	75.5	75.0	77.0	73.0
30	76.2	76.1	77.0	74.0
40	79.0	76.4	77.9	75.0
50	79.9	77.0	78.0	77.0
60	80.4	77.1	79.0	79.0
75	81.1	78.0	80.1	80.0
100	81.9	78.1	81.0	82.0
125	82.5	78.3	82.1	82.0
150	83.0	79.0	82.4	85.0
200	83.5	79.4	449T - 83.0 505UZ - 83.0	89.0
250	N/A	449T - 81.0 505UZ - 81.0	449T - 84.0 586/7 - 84.0	95.0
300	N/A	449T - 81.4 586/7 - 81.4	449T - 86.0 586/7 - 86.0	95.0
350	N/A	82.0	86.0	N/A
400	N/A	82.0	86.0	N/A
450	N/A	82.0	86.0	N/A
500	N/A	82.0	86.0	N/A

DECIBEL LEVELS (S Factory)

HP	Noise Level Lw dB(A)		
	3600 RPM	1800 RPM	1200 RPM
1	N/A	65.0	61.3
1.5	76.3	68.0	67.0
2	76.9	68.8	68.5
3	77.5	74.0	70.0
5	77.9	74.0	72.8
7.5	79.1	76.4	75.0
10	80.3	74.3	76.0
15	80.8	74.6	77.0
20	81.0	75.0	78.0
25	81.9	76.0	79.0
30	82.2	77.1	79.0
40	83.0	77.4	79.9
50	83.9	78.0	80.0
60	84.4	78.5	81.0
75	85.1	78.6	82.1
100	85.9	79.1	83.0
125	86.5	79.3	84.1
150	87.0	79.5	84.4
200	88.5	80.4	N/A
250	N/A	N/A	95
300	N/A	112	95
350	N/A	112	95
400	N/A	112	95
450	N/A	112	95
500	N/A	112	112

DECIBEL LEVELS (M Factory)

HP	Noise Level Lw dB(A)		
	3600 RPM	1800 RPM	1200 RPM
1	N/A	70.0	64.0
1.5	85.0	70.0	67.0
2	85.0	70.0	67.0
3	88.0	74.0	71.0
5	88.0	74.0	71.0
7.5	91.0	79.0	75.0
10	91.0	79.0	75.0
15	94.0	84.0	80.0
20	94.0	84.0	80.0
25	94.0	88.0	83.0
30	94.0	88.0	83.0
40	100	89.0	83.0
50	100	89.0	86.0
60	101	95.0	90.0
75	101	95.0	90.0
100	102	98.0	94.0
125	104	100	94.0
150	104	100	98.0
200	107	103	100
250	107	105	100
300	110	105	100

DECIBEL LEVELS (PREMIUM EFFICIENCY MOTORS)

HP	Noise Level Lw dB(A)		
	3600 RPM	1800 RPM	1200 RPM
1	---	65.0	64.0
1.5	70.0	66.0	67.0
2	70.0	66.0	67.0
3	75.0	68.0	67.0
5	75.0	68.0	67.0
7.5	77.0	70.0	70.0
10	77.0	70.0	70.0
15	87.0	75.0	80.0
20	88.0	75.0	80.0
25	88.0	85.0	81.0
30	88.0	85.0	81.0
40	90.0	85.0	82.0
50	90.0	85.0	83.0
60	91.0	88.0	85.0
75	91.0	88.0	88.0
100	94.0	89.0	92.0
125	97.0	90.0	92.0
150	97.0	92.0	92.0
200	99.0	92.0	94.0

SECTION XVII: Fan Dimensions

FAN DIMENSIONS (B Factory)

Frame Size	A	B	D	E	L	# Of Blades	Material
140	1-3/8"	4-1/16"	1-3/4"	15/16"	7/8"	6	Plastic
180	1-3/8"	4-1/16"	1-3/4"	15/16"	7/8"	6	Plastic
210	1-5/16"	5-1/16"	2-1/6"	1-1/2"	1-3/8"	15	Plastic
250	1-13/16"	5-9/10"	2-3/8"	1-11/16"	1-9/16"	6	Plastic
280 2 Pole	2-1/2"	6-7/10"	2-13/16"	1-5/8"	1-3/8"	6	Plastic
280 4/6 Pole	2-1/2"	7-1/2"	2-13/16"	1-5/8"	1-3/8"	6	Plastic
320 2 Pole	1-15/16"	7-1/2"	2-9/16"	1-11/16"	1-9/16"	6	Plastic
320 4/6 Pole	1-1/2"	10-1/2"	2-7/8"	1-11/16"	1-9/16"	6	Plastic
360 2 Pole	2-11/16"	7-7/8"	3-7/16"	2-5/16"	1-9/16"	6	Plastic
360 4/6 Pole	2-11/16"	9-3/7"	3-7/16"	2-5/16"	1-9/16"	6	Plastic
400 2 Pole	3-1/8"	8-13/20"	4-5/16"	2-7/16"	1-3/4"	6	Plastic
400 4/6 Pole	3-1/8"	10-12/19"	4-5/16"	2-7/16"	1-3/4"	6	Plastic
440 2 Pole	3-1/8"	8-13/20"	4-1/16"	2-7/16"	1-3/4"	10	Plastic
440 4/6 Pole	3-15/16"	12-3/5"	4-1/8"	2-7/16"	1-3/4"	12	Plastic
449 2 Pole	3-1/8"	12-3/5"	4-5/16"	2-7/16"	1-3/4"	6	Aluminum
449 4/6 Pole	3-15/16"	18-1/2"	4-1/8"	2-7/16"	1-3/4"	12	Aluminum
500 2 Pole	4-5/16"	13-13/16"	4-3/4"	2-15/16"	2-3/8"	12	Aluminum
500 4/6 Pole	4-5/16"	21-11/16"	5-5/16"	3-9/16"	2-3/8"	18	Aluminum
580 4 Pole	5-15/16"	16-9/16"	5-5/16"	3-9/16"	3-1/8"	9	Aluminum
580 6 Pole	5-15/16"	18-1/8"	5-5/16"	3-9/16"	3-1/8"	9	Aluminum
580 6 Pole 500 HP	5-15/16"	20-1/2"	5-5/16"	3-9/16"	3-1/8"	9	Aluminum

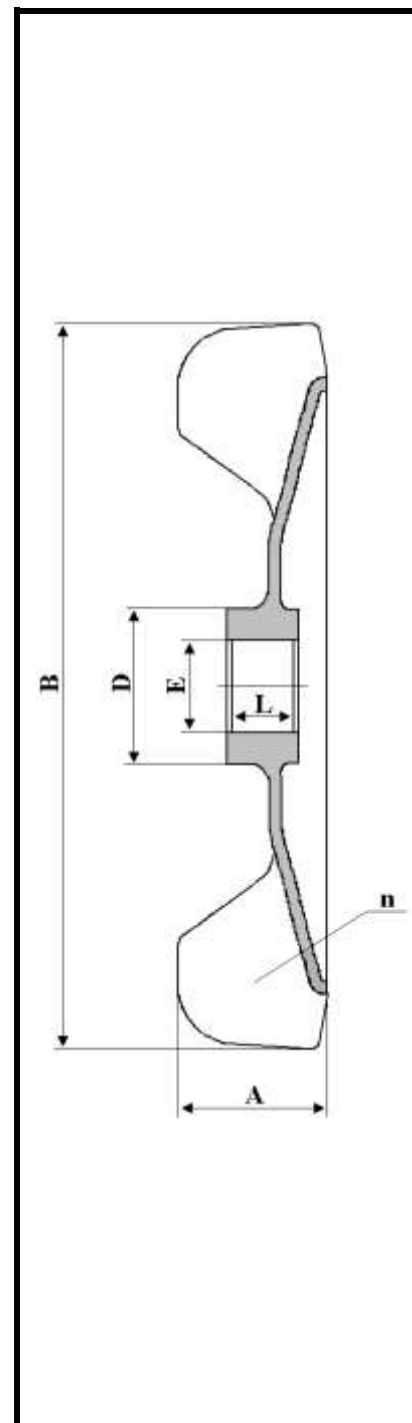

FAN DIMENSIONS (S Factory)

Frame Size	A	B	D	E	L	# Of Blades	Material
140	1-3/8"	4-1/16"	1-3/4"	15/16"	7/8"	6	Plastic
180	1-3/8"	4-1/16"	1-3/4"	15/16"	7/8"	6	Plastic
210	1-5/16"	5-1/16"	2-1/6"	1-1/2"	1-3/8"	15	Plastic
250	1-13/16"	5-9/10"	2-3/8"	1-11/16"	1-9/16"	6	Plastic
280 2 Pole	2-1/2"	6-7/10"	2-13/16"	1-5/8"	1-3/8"	6	Plastic
280 4/6 Pole	2-1/2"	7-1/2"	2-13/16"	1-5/8"	1-3/8"	6	Plastic
320 2 Pole	1-15/16"	7-1/2"	2-9/16"	1-11/16"	1-9/16"	6	Plastic
320 4/6 Pole	1-1/2"	10-1/2"	2-7/8"	1-11/16"	1-9/16"	6	Plastic
360 2 Pole	2-11/16"	7-7/8"	3-7/16"	2-5/16"	1-9/16"	6	Plastic
360 4/6 Pole	2-11/16"	9-3/7"	3-7/16"	2-5/16"	1-9/16"	6	Plastic
400 2 Pole	3-1/8"	8-13/20"	4-5/16"	2-7/16"	1-3/4"	6	Plastic
400 4/6 Pole	3-1/8"	10-12/19"	4-5/16"	2-7/16"	1-3/4"	6	Plastic
440 2 Pole	3-1/8"	8-13/20"	4-1/16"	2-7/16"	1-3/4"	10	Plastic
440 4/6 Pole	3-15/16"	12-3/5"	4-1/8"	2-7/16"	1-3/4"	12	Plastic
449 2 Pole	N/A	N/A	N/A	N/A	N/A	N/A	N/A
449 4/6 Pole	3-15/16"	18-1/2"	4-1/8"	2-7/16"	1-3/4"	12	Aluminum
500 2 Pole	N/A	N/A	N/A	N/A	N/A	N/A	N/A
500 4/6 Pole	N/A	N/A	N/A	N/A	N/A	N/A	N/A
580 4 Pole	123	22-1/2"	5-3/10"	3-1/2"	2-2/5"	19	Aluminum
580 6 Pole	123	22-1/2"	5-3/10"	3-1/2"	2-2/5"	19	Aluminum
580 6 Pole 500 HP	123	22-1/2"	5-3/10"	3-1/2"	2-2/5"	19	Aluminum

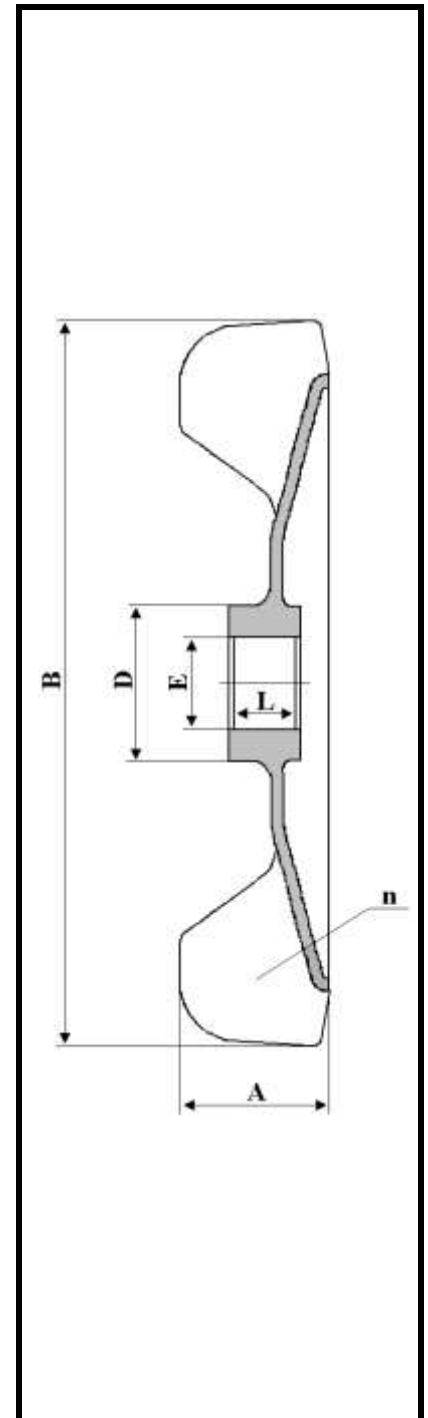

FAN DIMENSIONS (M Factory)

Frame Size	A	B	D	E	L	# Of Blades	Material
OLD 140 2/4/6 Pole	1-3/16"	5-5/16"		15/16"	7/8"	6	Fiberglass
NEW * 140/180 2/4/6 Pole	1-1/32"	3-15/16"		3/4"	7/8"	6	Fiberglass
OLD 180 2 Pole	1-3/8"	5-5/16"		1-1/8"	1-3/16"	6	Fiberglass
OLD 180 4/6 Pole	1-3/8"	6-3/32"		1-1/8"	1-3/16"	6	Fiberglass
210 2 Pole	1-3/8"	5-5/16"		1-1/8"	1-3/16"	6	Fiberglass
210 4/6 Pole	1-3/8"	6-3/32"		1-1/8"	1-3/16"	6	Fiberglass
250 2 Pole	1-25/32"	7-9/32"		1-1/2"	1-3/8"	6	Fiberglass
250 4/6 Pole	1-31/32"	8-15/32"		1-1/2"	1-3/8"	6	Fiberglass
280 2 Pole	1-25/32"	7-9/32"		1-1/2"	1-3/8"	6	Fiberglass
280 4/6 Pole	1-31/32"	8-15/32"		1-1/2"	1-3/8"	6	Fiberglass
320 2/4 Pole	2-3/8"	6-45/64"		1-45/64"	1-3/16"	7	Fiberglass
320 6 Pole	2"	8-1/2"		1-45/64"	1-3/16"	6	Fiberglass
360 2/4/6 Pole	2-9/16"	9-27/32"		2-3/64"	1-3/8"	6	Fiberglass
400 2 Pole	2"	8-1/2"		1-45/64"	1-9/16"	6	Fiberglass
400 4/6 Pole	2-61/64"	10-15/64"		2-9/32"	1-37/64"	6	Fiberglass
444/5/7 2 Pole	3.543"	9.055"		2.677"	1.969"	7	Fiberglass
444/5/7 4/6 Pole	3.15"	9.843"		2.677"	1.772"	6	Fiberglass

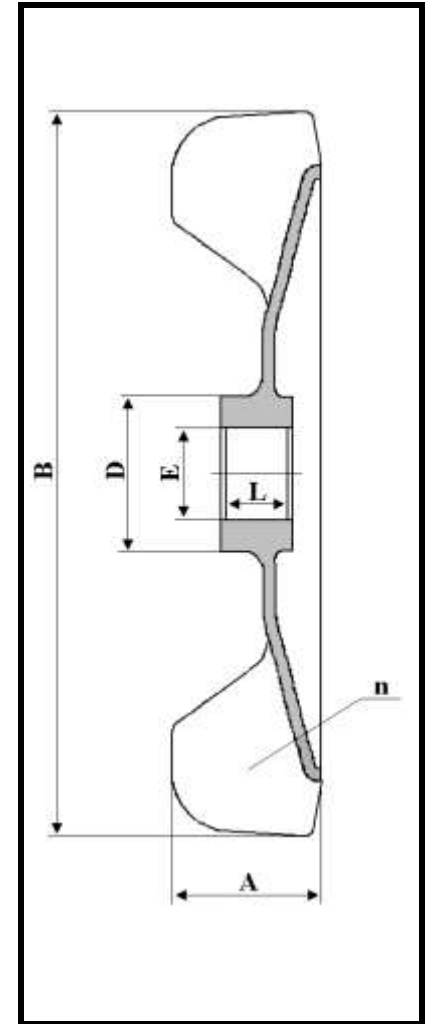

* NEW 140 Fan Adapted In April 2008
 * NEW 180 Fan Adapted In October 2008

FAN DIMENSIONS (Premium Efficiency Motors)

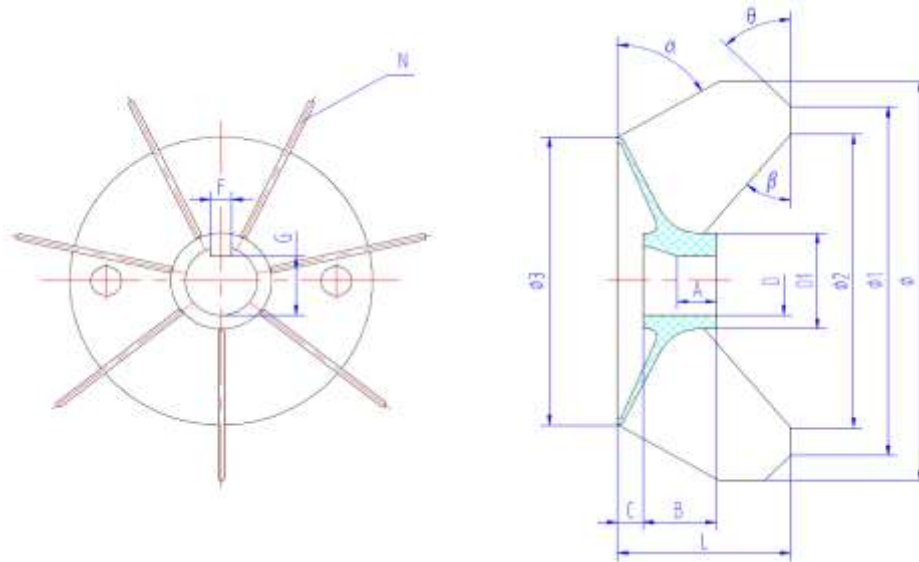

Frame Size	A	B	C	D	DI	F	G	N	L	Ø	Ø1	Ø2	Ø3	α	β	Ø	Material
140	0.472	0.787	0.236	0.756	1.06	0.236	0.63	5	1.02	3.15	2.91	2.68	2.2	2.36	1.18	1.57	Plastic
180	0.472	0.787	0.236	0.953	1.26	0.197	0.807	5	1.18	3.54	3.23	2.94	2.52	2.36	1.38	1.57	Plastic
210	0.354	0.866	---	0.953	1.77	0.315	0.795	5	0.945	4.02	---	---	2.36	---	---		Plastic
250	0.551	0.984	0.236	1.5	1.97	0.394	1.32	5	1.77	5.51	5.04	4.41	4.13	2.36	1.38	1.57	Plastic
280 2 Pole	0.63	1.18	0.236	1.69	2.13	0.472	1.5	5	1.97	6.1	5.47	4.8	4.33	2.36	1.38	1.38	Plastic
280 4/6 Pole	0.63	1.18	0.236	1.69	2.56	0.472	1.5	5	2.36	7.09	6.46	5.75	5.16	2.36	1.38	1.77	Plastic
320 2 Pole	0.394	1.38	0.236	1.65	2.83	0.472	1.46	6	2.48	6.69	6.3	---	6.3	---	2.13	---	Plastic
320 4/6 Pole	0.394	1.38	0.315	1.65	2.83	0.472	1.46	6	2.48	7.48	6.3	---	6.3	---	2.13	1.42	Plastic
360 2 Pole	1.02	1.57	0.236	2.05	2.52	0.551	1.84	7	2.76	7.09	6.46	5.79	4.96	2.36	1.57	1.77	Plastic
360 4/6 Pole	1.02	1.57	0.236	2.05	2.52	0.551	1.84	7	2.76	8.66	7.87	7.09	6.06	2.17	1.38	1.38	Plastic
400 2 Pole	0.984	1.57	0.394	2.28	2.76	0.63	2.06	7	3.15	7.87	7.09	6.3	5.67	2.36	1.57	2.17	Plastic
400 4/6 Pole	0.945	1.77	0.394	2.28	2.91	0.709	2.02	9	3.54	9.84	9.06	8.27	6.93	2.36	1.38	1.97	Plastic
440 2 Pole	0.669	1.77	0.394	2.44	3.07	0.709	2.18	7	3.15	8.27	7.09	6.3	6.1	2.36	1.57	1.77	Plastic
440 4/6 Pole	0.669	1.77	0.394	2.44	3.07	0.709	2.18	9	3.15	10.24	9.06	8.27	7.32	2.17	1.18	1.97	Plastic
449 4/6 Pole	1.77	1.77	0.709	2.44	4.13	0.709	2.61	12	3.94	18.5	15.35	12.99	15.75	0.394	2.17	0.886	Cast Aluminum

SECTION XVIII: Junction Box Dimensions

JUNCTION BOX DIMENSIONS (B Factory)

Frame Size	XD	XC	AA (NPT)	H
143T	4.1"	4.5"	3/4"	2.3"
145T				
182T	4.6"	5.0"	1"	2.6"
184T				
213T	4.6"	5.0"	1"	2.6"
215T				
254T	6.3"	7.2"	1-1/2"	3.3"
256T				
284T	6.3"	7.2"	1-1/2"	3.3"
286T				
324T	9"	10.6"	2"	5.3"
326T				
364T	9"	10.6"	2"	5.3"
365T				
404T	9.8"	11.7"	3"	7.1"
405T				
444T	11.3"	11.7"	2 x 3"	7.1"
445T				
447T				
449T	11.3"	11.7"	2 x 3"	7.1"
505UZ	11.8"	13.8"	2 x 3"	6.5"
586/7	13.9"	16.1"	2 x 3"	7.6"

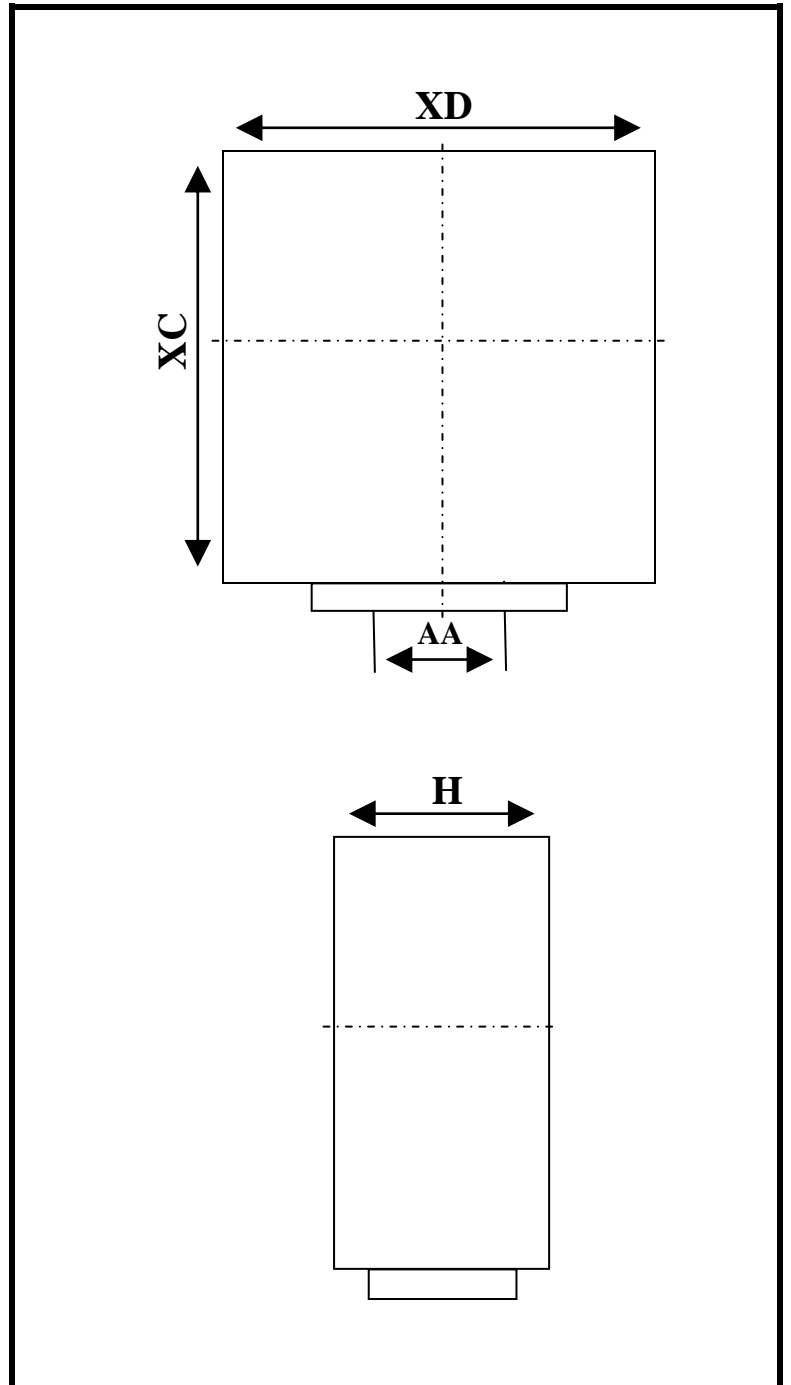

JUNCTION BOX DIMENSIONS (S Factory)

Frame Size	XD	XC	AA (NPT)	H
143T	4.1"	4.5"	3/4"	2.3"
145T				
182T	4.6"	5.0"	1"	2.6"
184T				
213T	4.6"	5.0"	1"	2.6"
215T				
254T	6.3"	7.2"	1-1/2"	3.3"
256T				
284T	6.3"	7.2"	1-1/2"	3.3"
286T				
324T	9"	10.6"	2"	5.3"
326T				
364T	9"	10.6"	3"	5.3"
365T				
404T	9.8"	11.7"	3"	7.1"
405T				
444T	11.3"	11.7"	2 x 3"	7.1"
445T				
447T				
449T	11.3"	11.7"	2 x 3"	7.1"
505UZ	N/A	N/A	N/A	N/A
586/7	15-1/2"	14	3	7-4/5"

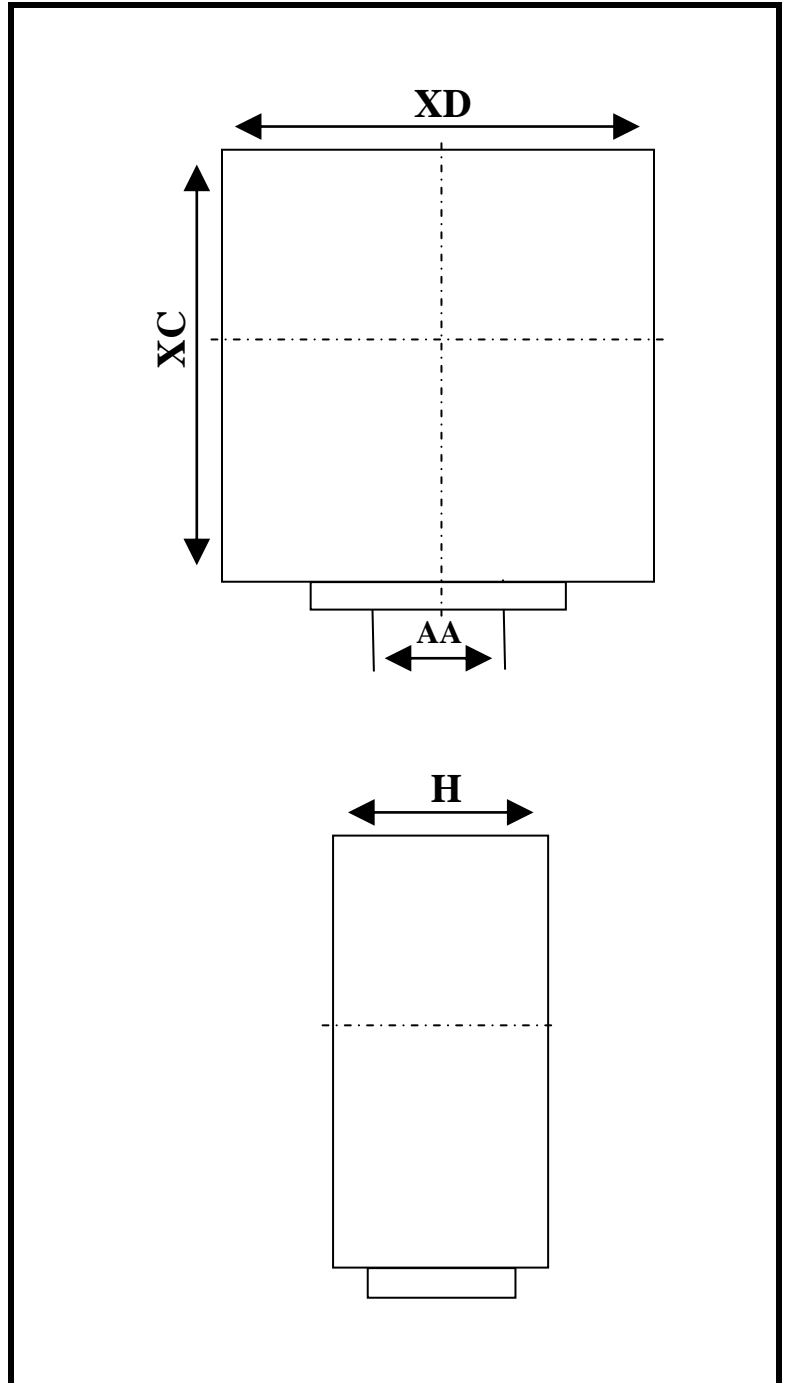

JUNCTION BOX DIMENSIONS (M Factory)

Frame Size	XD	XC	AA (NPT)	H
143T	4.1"	4.3"	3/4"	2.2"
145T				
182T	4.6"	4.9"	1"	2.6"
184T				
213T	4.6"	4.9"	1"	2.6"
215T				
254T	6.3"	6.8"	1-1/2"	3.3"
256T				
284T	6.3"	6.8"	1-1/2"	3.3"
286T				
324T	9.1"	9.9"	2"	5.1"
326T				
364T	9.1"	9.9"	3"	5.1"
365T				
404T	9.8"	10.9"	3"	6.1"
405T				
444T	N/A	N/A	N/A	N/A
445T				
447T				
449T	N/A	N/A	N/A	N/A
505UZ	N/A	N/A	N/A	N/A
586/7	N/A	N/A	N/A	N/A

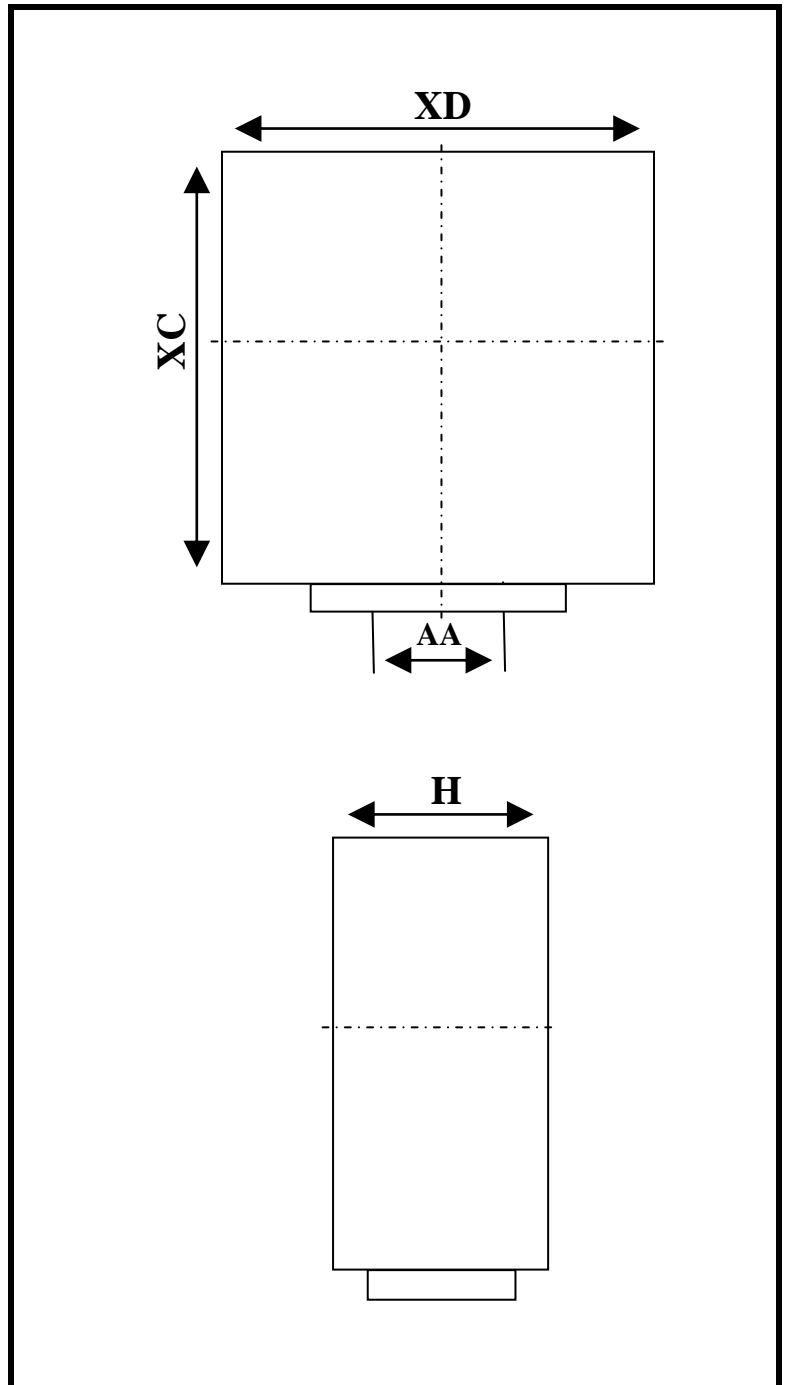

SECTION XIX:

Minimum Sheave Diameters

Frame Size	Horsepower At Synchronous Speed, RPM				V-Belt Sheave **			
	3600	1800	1200	900	Conventional A, B, C, D and E ‡‡		Narrow 3V, 5V and 8V ▲▲	
					Min. Pitch Diameter (Inches)	Max. Width (Inches) ▲	Min. Outside Diameter (Inches)	Max. Width (Inches) #
143T	1-1/2	1	3/4	1/2	2.2		2.2	
145T	2 - 3	1-1/2 - 2	1	3/4	2.4		2.4	
182T	3	3	1-1/2	1	2.4		2.4	
182T	5	---	---	---	2.6		2.4	
184T	---	---	2	1-1/2	2.4		2.4	
184T	5	---	---	---	2.6		2.4	
184T	7-1/2	5	---	---	3.0		3.0	
213T	7-1/2 - 10	7-1/2	3	2	3.0		3.0	
215T	10	---	5	3	3.0		3.0	
215T	15	10	---	---	3.8		3.8	
254T	15	---	7-1/2	5	3.8		3.8	
254T	20	15	---	---	4.4		4.4	
256T	20 - 25	---	10	7-1/2	4.4		4.4	
256T	---	20	---	---	4.6		4.4	
284T	---	---	15	10	4.6		4.4	
284T	---	25	---	---	5.0		4.4	
286T	---	30	20	15	5.4		5.2	
324T	---	40	25	20	6.0		6.0	
326T	---	50	30	25	6.8		6.8	
364T	---	---	40	30	6.8		6.8	
364T	---	60	---	---	7.4		7.4	
365T	---	---	50	40	8.2		8.2	
365T	---	75	---	---	9.0		8.6	
404T	---	---	60	---	9.0		8.0	
404T	---	---	---	50	9.0		8.4	
404T	---	100	---	---	10.0		8.6	
405T	---	---	75	60	10.0		10.0	
405T	---	100	---	---	10.0		8.6	
405T	---	125	---	---	11.5		10.5	
444T	---	---	100	---	11.0		10.0	
444T	---	---	---	75	10.5		9.5	
444T	---	125	---	---	11.0		9.5	
444T	---	150	---	---	---		10.5	
445T	---	---	125	---	12.5		12.0	
445T	---	---	---	100	12.5		12.0	
445T	---	150	---	---	---		10.5	
445T	---	200	---	---	---		13.2	

** Sheave dimensions are based on the following:

- A. Motor nameplate horsepower and speed.
- B. Belt service factor of 1.6 with belts tightened to belt manufacturers recommendations.
- C. Speed reduction of 5:1.
- D. Mounting of sheave on motor shaft in Accordance with 14.7.
- E. Center-to-center distance between sheaves approximately equal to the diameter of the larger sheave.
- F. Calculations based upon standards covered by the ‡‡ and ▲▲ footnotes, as applicable.

- ▲ The width of the sheave shall not be greater than that required to transmit the indicated horsepower but in no case shall it be wider than $2(N-W) - 0.25$.
- ▲▲ As covered by Standard Specifications for Drives Using Narrow V-Belts (3V, 5V and 8V)¹.
- # The width of the sheave shall not be greater than that required to transmit the indicated horsepower but in no case shall it be wider than (N-W).
- ‡‡ As covered by Engineering Standards Specifications for Drives Using Multiple V-Belts (A, B, C, D and E Cross Sections)¹.

