

# DATA SHEET

Premium Efficiency Motor: **PEWWE500-18-586/7UZ**

**60 Hz**

WorldWide Electric Corporation

1 (800) 808-2131

Worldwideelectric.net



Document Generated: 24-Jun-2024  
Document ID:

Customer:

## MOTOR INFORMATION

HP	500
RPM	1800
Phase	3
Frequency	60 Hz
Voltage	460 V
Frame Size	586/7
Enclosure	TEFC
Degree of Protection	IP55
Service Factor	1.15
Poles	4
Full Load Speed	1790
Insulation Class	F
Temp Rise	80°C
NEMA Code Letter	G
Duty Cycle	S1 / Continuous
Slip	0.56%
NEMA Design	B
Moment of Inertia	205 lb.ft.^2
Locked Rotor Time (Hot)	16 seconds
Sound Pressure Level	86 dB(A)
Number of Starts	2 Cold/ 1 Hot
Max Ambient Temperature	40°C
Max Elevation	1000 m.a.s.l (3300 f.a.s.l)
Mounting	F1
Rotation	Bi-Directional
Area of Classification	Class 1 Division 2 Groups A,B,C,D T3(200°C)
Inverter Rating	3:1 CT / 6:1 VT PWM Type
Standard	NEMA MG-1
Approvals	CSA-US, CE

## EFFICIENCY/POWER FACTOR

LOAD	EFF	P. F.
100%	96.2 %	0.91
75%	96.2 %	0.89
50%	96.0 %	0.85

## TORQUE

FULL LOAD	LRT	BDT
1466 lb.ft.	200 %	250 %

## AMPERAGE INFORMATION

	230V	460V
Full Load Amps	--A	535A
Locked Rotor Amps	--A	3625A
No Load Current	--A	130A
Usable at 208V	--A	

## BEARING INFORMATION

DE Bearing	NU326 C3
ODE Bearing	6324 C3
Grease Type	SKF LGHP 2
DE Regreasing Interval	1000 Hours
ODE Regreasing Interval	1500 Hours

## ADDITIONAL DATA

F2 Suitable	No
Shaft Material	4140 Carbon Steel
Connection Diagram	460 V - 6 Lead Δ
Approximate Weight	4718 lbs.

# MOTOR DRAWING

Premium Efficiency Motor: **PEWWE500-18-586/7UZ**

WorldWide Electric Corporation

1 (800) 808-2131

Worldwideelectric.net

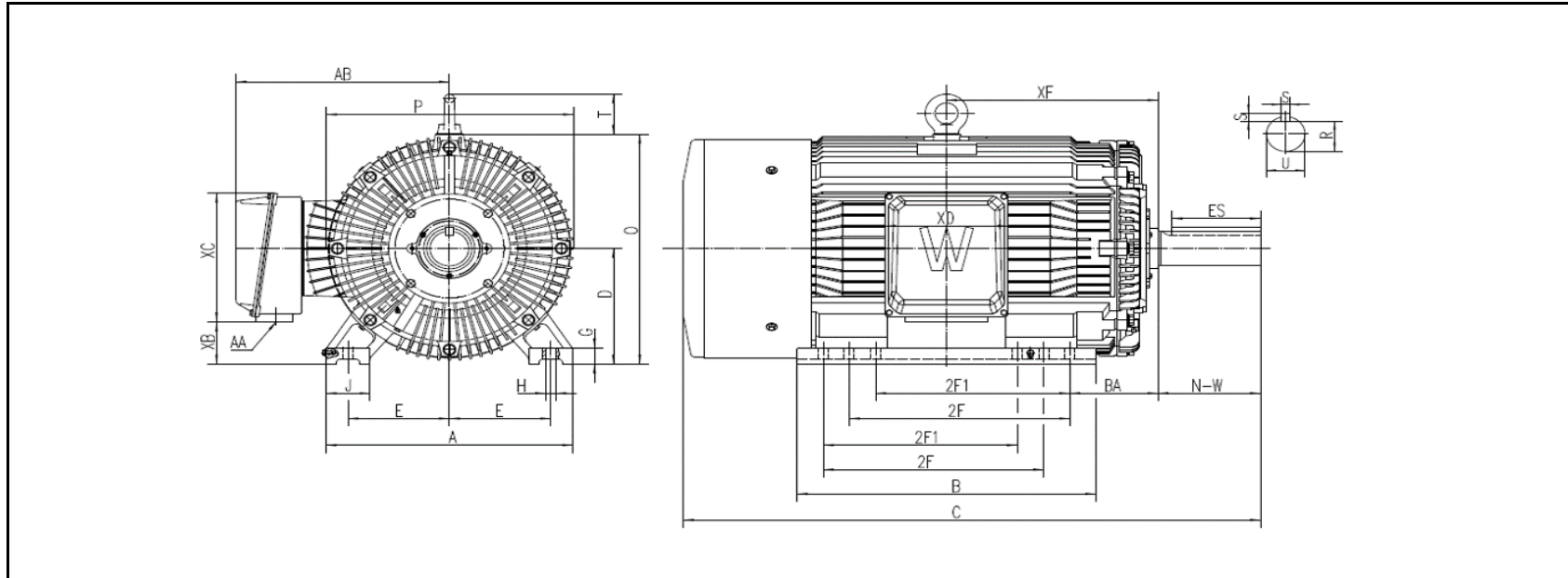

## DIMENSION - INCHES

MOUNTING					A	B	C	D	G	J	P	O	T	AB
E	2F1	2F	H	BA										
11.5	22	25	1.125	10	27.992	33.858	66.231	14.5	2.047	5	28.011	28.87	5.02	24.212

SHAFT & KEY				
S	ES	R	N-W	U
1	10	3.817	11.625	4.375

TERMINAL BOX				
AA	XB	XC	XD	XF
2 X 3	5.287	16.158	13.937	23.976

# PERFORMANCE CURVES

WorldWide Electric Corporation

1 (800) 808-2131

Worldwideelectric.net



Premium Efficiency Motor:

**PEWWE500-18-586/7UZ**

Document Generated: 24-Jun-2024  
Document ID:

Customer:

Motor Type	PEWWE		FL Speed	1790		
Output Rating (HP)	500		LRT (%FLT)	200	460 volt FLA	535 A
Full Load Torque	1466	lb.ft	BDT (%FLT)	250	230 volt FLA	-- A
Rotor Wk^2	205	lb-ft^2				

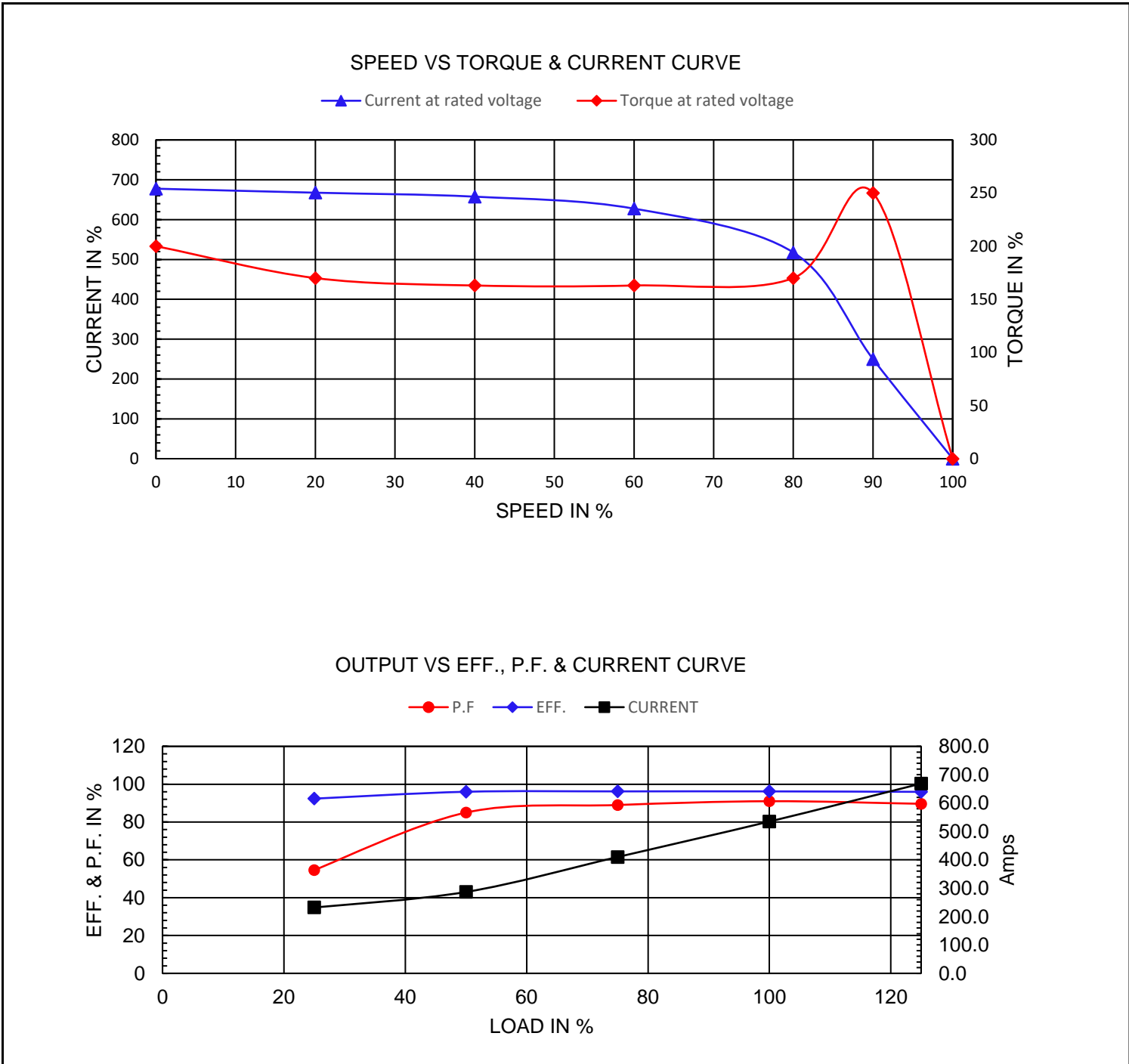

# NAMEPLATE / WIRING

WorldWide Electric Corporation

1 (800) 808-2131

Worldwideelectric.net



Premium Efficiency Motor: **PEWWE500-18-586/7UZ**

Document Generated: 24-Jun-2024  
Document ID:

Customer:

## SAMPLE NAMEPLATE DATA

		<b>NEMA Premium</b>		<b>3-PHASE INDUCTION MOTOR</b>		259277 	
Model		Ser No.		Connection			
HP	S.F.	IP	End				
Frame	P.F.	Code	Type				
Voltage	Hz	Ins Cl	Rating °C Amb Cont				
Amps	RPM	Design	Date				
Nom.Eff. FL % 3/4 % V 3:1 CT 6:1 VT PWM VFD 1.0SF							
Class I DIV. 2 Groups A B C D				Amb.40°C			
DE Brng				Grease type: LGHP 2 (compatible with polyrex)			
ODE Brng							
<b>WorldWide Electric Corporation</b>							

Model	PEWWE500-18-586/7UZ						
HP	500	S.F.	1.15	IP	IP55	Encl	TEFC
Frame	586/7	P.F.	0.91	Code	G	Type	
Voltage	460 V	Hz	60 Hz	Ins Cl	F	Ambient	40°C
Amps	535	RPM	1790	Design	B	DE Brng NU326 C3	
Nom.Eff.	FL	96.2%	3/4	96.2%	ODE Brng 6324 C3		
Class 1 Division 2 Groups A,B,C,D						T3(200°C)	
						Grease type: SKF LGHP 2	
50Hz	--	HP	--	--	A	-- rpm	