

DATA SHEET

Premium Efficiency Motor: **PEWWE400-36-L449TS-IB**

60 Hz

WorldWide Electric Corporation

1 (800) 808-2131

Worldwideelectric.net



Document Generated: 20-Jun-2024
Document ID:

Customer:

MOTOR INFORMATION	
HP	400
RPM	3600
Phase	3
Frequency	60 Hz
Voltage	460V
Frame Size	L449TS
Enclosure	TEFC
Degree of Protection	IP55
Service Factor	1.15
Poles	2
Full Load Speed	3585
Insulation Class	F
Temp Rise	80°C
NEMA Code Letter	L
Duty Cycle	S1 / Continuous
Slip	0.42%
NEMA Design	A
Moment of Inertia	57.1 lb.ft.^2
Locked Rotor Time (Hot)	21 seconds
Sound Pressure Level	88 dB(A)
Number of Starts	2 Cold/ 1 Hot
Max Ambient Temperature	40°C
Max Elevation	1000 m.a.s.l (3300 f.a.s.l)
Mounting	F1
Rotation	Bi-Directional
Area of Classification	Class 1 Division 2 Groups A,B,C,D T3(200°C)
Inverter Rating	10:1 CT / 20:1 VT PWM Type
Standard	NEMA MG-1
Approvals	CSA-US, CE

EFFICIENCY/POWER FACTOR		
LOAD	EFF	P. F.
100%	95.8 %	0.92
75%	95.9 %	0.90
50%	95.0 %	0.85

TORQUE		
FULL LOAD	LRT	BDT
586 lb.ft.	220 %	450 %

AMPERAGE INFORMATION		
	230V	460V
Full Load Amps	--A	425A
Locked Rotor Amps	--A	4560A
No Load Current	--A	107A
Usable at 208V	--A	

BEARING INFORMATION	
DE Bearing	6314 C3
ODE Bearing	6314 M/C3
Grease Type	SKF LGHP 2
DE Regreasing Interval	1800 Hours
ODE Regreasing Interval	1800 Hours

ADDITIONAL DATA	
F2 Suitable	Yes
Shaft Material	1045 Carbon Steel
Connection Diagram	460 V - 6 Lead Δ
Approximate Weight	3065 lbs.

MOTOR DRAWING

Premium Efficiency Motor: **PEWWE400-36-L449TS-IB**

WorldWide Electric Corporation

1 (800) 808-2131

Worldwideelectric.net

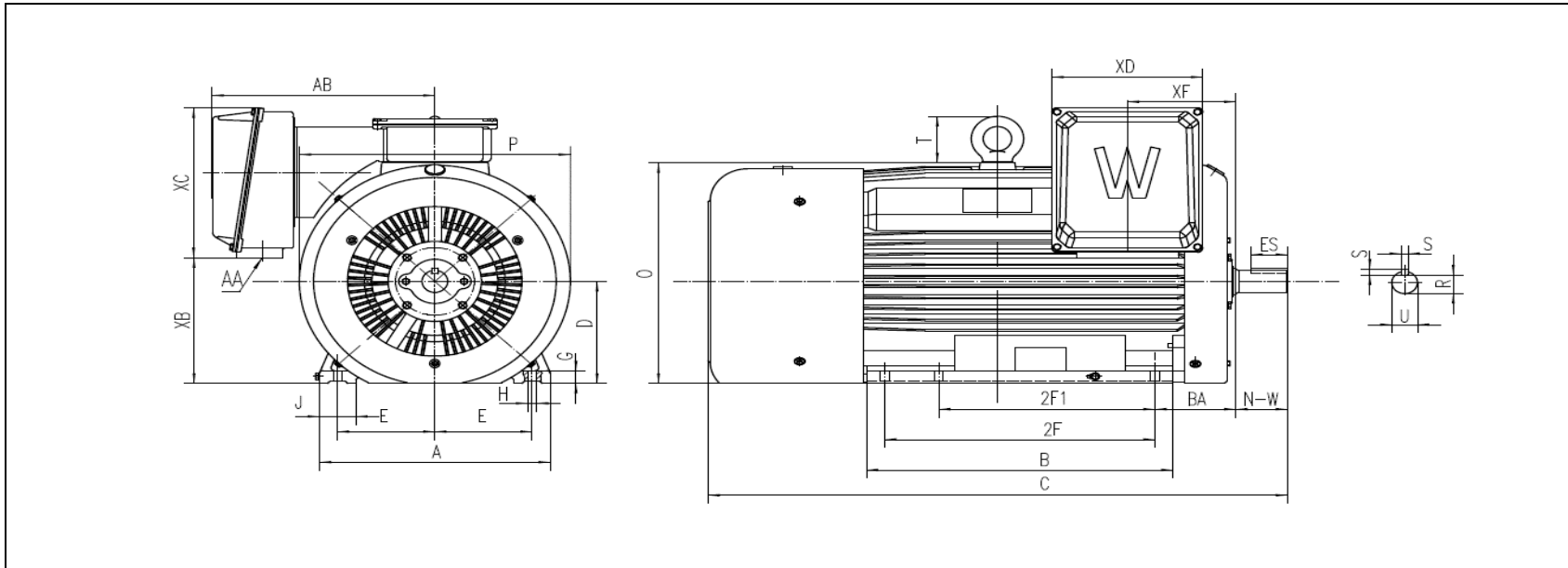

DIMENSION - INCHES

MOUNTING					A	B	C	D	G	J	P	O	T	AB
E	2F1	2F	H	BA										
9	20	25	0.81	7.5	21.339	28.346	53.587	11	1.378	3.346	25.079	23.795	5.02	20.629

SHAFT & KEY				
S	ES	R	N-W	U
0.625	3.03	2.021	4.75	2.375

TERMINAL BOX				
AA	XB	XC	XD	XF
2X3	13.559	16.158	13.937	10.059

DIMENSION - INCHES

PERFORMANCE CURVES

Premium Efficiency Motor:

PEWWE400-36-L449TS-IB

WorldWide Electric Corporation

1 (800) 808-2131

Worldwideelectric.net



Document Generated: 20-Jun-2024
Document ID:

Customer:

Motor Type	PEWWE				
Output Rating (HP)	400		FL Speed	3585	
Full Load Torque	586	lb.ft	LRT (%FLT)	220	460 volt FLA 425 A
Rotor Wk^2	57.1	lb-ft^2	BDT (%FLT)	450	230 volt FLA -- A

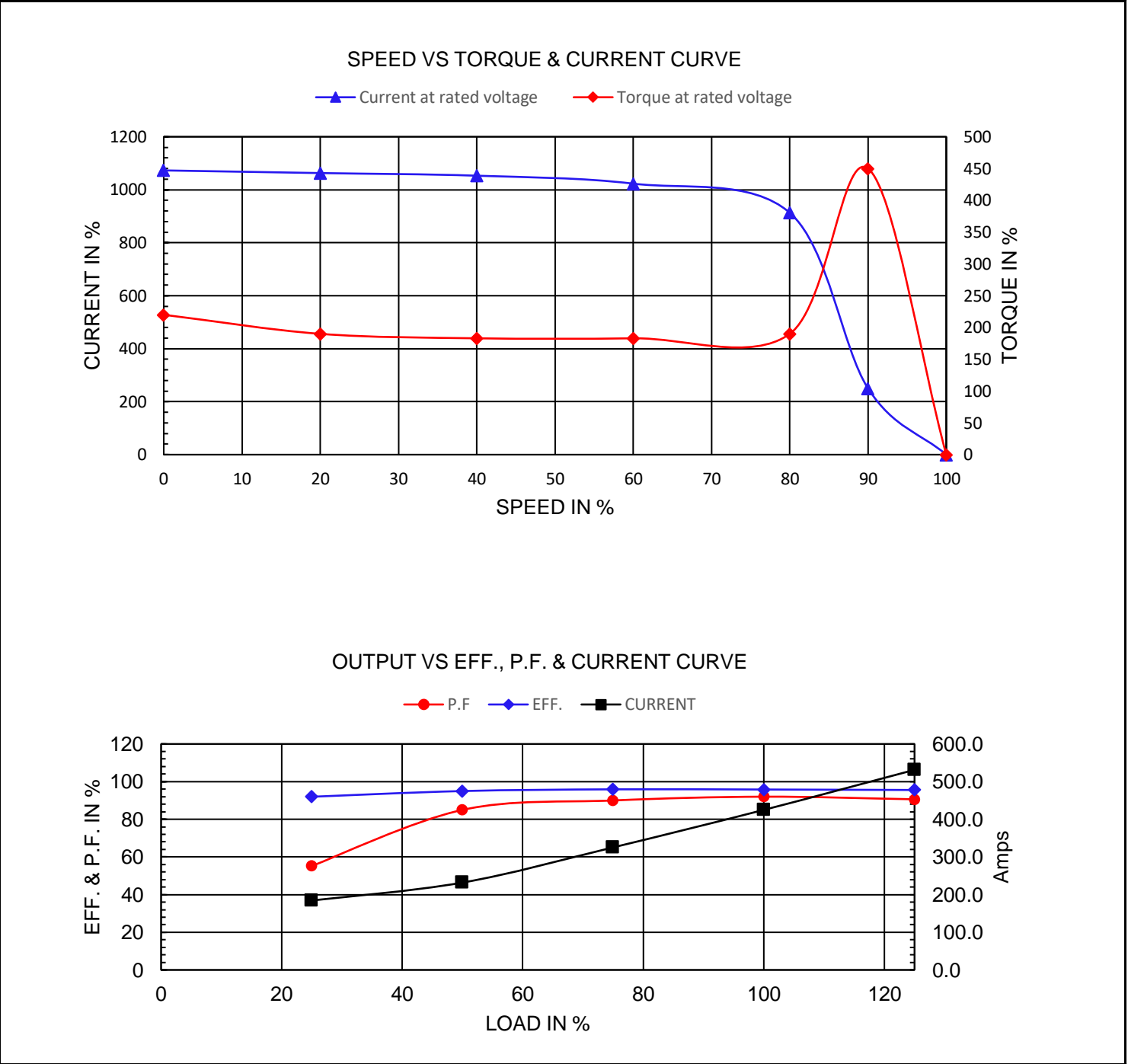

NAMEPLATE / WIRING

WorldWide Electric Corporation

1 (800) 808-2131

Worldwideelectric.net



Premium Efficiency Motor:

PEWWE400-36-L449TS-IB

Document Generated: 20-Jun-2024
Document ID:

Customer:

SAMPLE NAMEPLATE DATA

		NEMA Premium		3-PHASE INDUCTION MOTOR		259277 										
Model		Ser No.		Connection												
HP	S.F.	IP	Encl	<table border="1"> <tr> <td>6</td> <td>4</td> <td>5</td> </tr> <tr> <td>1</td> <td>2</td> <td>3</td> </tr> <tr> <td>L1</td> <td>L2</td> <td>L3</td> </tr> </table>				6	4	5	1	2	3	L1	L2	L3
6	4	5														
1	2	3														
L1	L2	L3														
Frame	P.F.	Code	Type													
Voltage	Hz	Ins Cl	Rating	°C Amb Cont												
Amps	RPM	Design	Date													
Nom.Eff.	FL	% 3/4	%	V	10:1 CT	20:1 VT	PWM VFD 1.0SF									
Class I DIV. 2 Groups A B C D				Amb.40°C												
DE Brng				Grease type: LGHP 2 (compatible with polyrex)												
ODE Brng																
WorldWide Electric Corporation																

Model	PEWWE400-36-L449TS-IB						
HP	400	S.F.	1.15	IP	IP55	Encl	TEFC
Frame	L449TS	P.F.	0.92	Code	L	Type	
Voltage	460V	Hz	60 Hz	Ins Cl	F	Ambient	40°C
Amps	425	RPM	3585	Design	A	DE Brng 6314 C3	
Nom.Eff.	FL	95.8%	3/4	95.9%	ODE Brng 6314 M/C3		
Class 1 Division 2 Groups A,B,C,D						T3(200°C)	
						Grease type: SKF LGHP 2	