

DATA SHEET

Premium Efficiency Motor: **LAM100-18-405TS**

60 Hz

WorldWide Electric Corporation

1 (800) 808-2131

Worldwideelectric.net



Document Generated: 8-Sep-2023
Document ID:

Customer:

MOTOR INFORMATION	
HP	100
RPM	1800
Phase	3
Frequency	60 Hz
Voltage	230/460
Frame Size	404/5TS
Enclosure	TEFC
Degree of Protection	IP55
Service Factor	1.25
Poles	4
Full Load Speed	1785
Insulation Class	F
Temp Rise	80°C
NEMA Code Letter	G
Duty Cycle	S1 / Continuous
Slip	0.83%
NEMA Design	B
Moment of Inertia	27.147 lb.ft.^2
Locked Rotor Time (Hot)	12 seconds
Sound Pressure Level	98 dB(A)
Number of Starts	2 Cold/1 Hot
Max Ambient Temperature	40°C
Max Elevation	1000 m.a.s.l (3300 f.a.s.l)
Mounting	Rigid
Rotation	Bi-Directional
Area of Classification	Class 1 Division 2 Groups A,B,C,D T3B
Inverter Rating	10:1 CT / 20:1 VT
Standard	NEMA MG-1
Approvals	UL, CE, IEEE45, ABS

EFFICIENCY/POWER FACTOR		
LOAD	EFF	P. F.
100%	95.4 %	0.86
75%	95.4 %	0.86
50%	94.8 %	0.81

TORQUE		
FULL LOAD	LRT	BDT
296.5 lb.ft.	154 %	244 %

AMPERAGE INFORMATION		
	230V	460V
Full Load Amps	229.8A	114.9A
Locked Rotor Amps	1491.4A	745.7A
No Load Current	53.8A	26.9A
Usable at 208V		249.7 A

BEARING INFORMATION	
DE Bearing	6316 C3
ODE Bearing	6313 C3
Grease Type	Mobil Polyrex EM
DE Regreasing Interval	2400 Hours
ODE Regreasing Interval	3600 Hours
Grease Quantity	33g/23g

ADDITIONAL DATA	
F2 Suitable	Yes
Shaft Material	AISI 1045
Connection Diagram	12 Lead Delta
Approximate Weight	1151 lbs.

MOTOR DRAWING

Premium Efficiency Motor: **LAM100-18-405TS**

WorldWide Electric Corporation

1 (800) 808-2131

Worldwideelectric.net

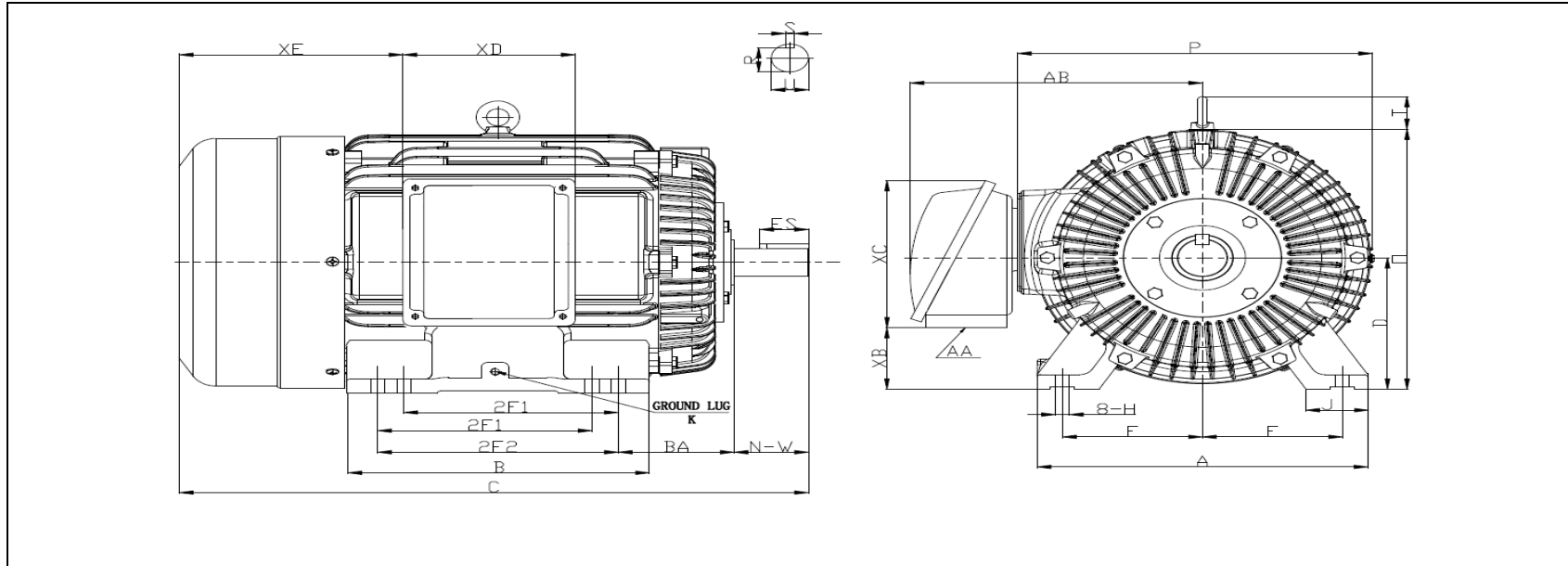

DIMENSION - INCHES

MOUNTING					A	B	C	D	G	J	P	O	T	AB
E	2F1	2F2	H	BA										
8	12.25	13.75	0.81	6.62	18.89	17.32	37.75	10	1.181	3.937	20.27	20.67	2.81	18.215

SHAFT & KEY				
S	ES	R	N-W	U
0.5	2.78	1.845	4.25	2.125

TERMINAL BOX				
AA	XB	XC	XD	XE
3 NPT	5.29	11.27	9.17	12.32

GROUND LUG
M12

PERFORMANCE CURVES

WorldWide Electric Corporation

1 (800) 808-2131

Worldwideelectric.net



Premium Efficiency Motor:

LAM100-18-405TS

Document Generated: 8-Sep-2023
Document ID:

Customer:

Motor Type	AEH3		FL Speed	1785	
Output Rating (HP)	100		LRT (%FLT)	154	460 volt FLA 114.9
Full Load Torque	296.5	lb.ft	BDT (%FLT)	244	230 volt FLA 229.8
Rotor Wk^2	27.147	lb-ft^2			

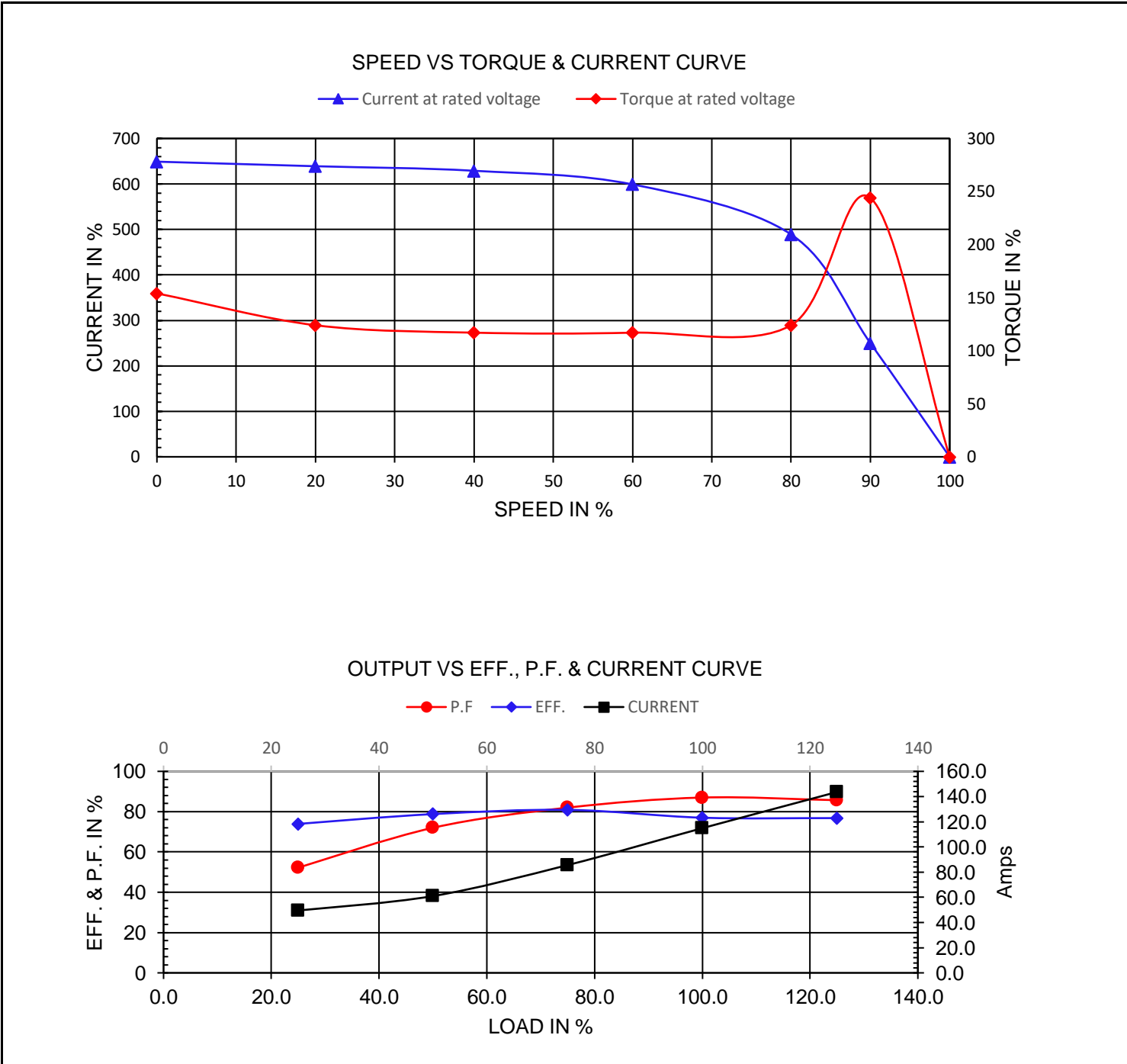

NAMEPLATE / WIRING

Premium Efficiency Motor: **LAM100-18-405TS**

WorldWide Electric Corporation

1 (800) 808-2131

Worldwideelectric.net



Document Generated: 8-Sep-2023
Document ID:

Customer:

SAMPLE NAMEPLATE DATA

		THREE PHASE SEVERE DUTY MOTOR I EEE45																									
Model :		Encl :		Type :		SN :		<table style="width: 100%; text-align: center;"> <tr> <td>7</td><td>8</td><td>9</td></tr> <tr> <td>6</td><td>4</td><td>5</td></tr> <tr> <td>12</td><td>10</td><td>11</td></tr> <tr> <td>1</td><td>2</td><td>3</td></tr> <tr> <td>L1</td><td>L2</td><td>L3</td></tr> <tr> <td colspan="3">230 V</td></tr> </table>		7	8	9	6	4	5	12	10	11	1	2	3	L1	L2	L3	230 V		
7	8	9																									
6	4	5																									
12	10	11																									
1	2	3																									
L1	L2	L3																									
230 V																											
HP :	Poles :	FR:	Ins:	Duty: Cont	IP :	Max Amb 40°C		<table style="width: 100%; text-align: center;"> <tr> <td>7</td><td>8</td><td>9</td></tr> <tr> <td>4</td><td>5</td><td>6</td></tr> <tr> <td>12</td><td>10</td><td>11</td></tr> <tr> <td>1</td><td>2</td><td>3</td></tr> <tr> <td>L1</td><td>L2</td><td>L3</td></tr> <tr> <td colspan="3">460 V</td></tr> </table>		7	8	9	4	5	6	12	10	11	1	2	3	L1	L2	L3	460 V		
7	8	9																									
4	5	6																									
12	10	11																									
1	2	3																									
L1	L2	L3																									
460 V																											
Hz :	CODE :		Hz :	HP :	Design :		<p>UL certified Class I, Division II, Groups A,B,C,D T3B</p>																				
Volts :	P.F :		Volts :	DE BRG :																							
Amps :	Eff :		Amps :	ODE BRG :																							
RPM :	S.F :		RPM :	WT :																							
CC306B		LOUIS ALLIS A WORLDWIDE ELECTRIC COMPANY																									

Model:	LAM100-18-405TS	Encl:	TEFC	Type:	AEH3		
HP:	100	Poles	4	FR:	404/5TS	IP:	55
Hz:	60	CODE:	G	Hz	50	HP:	100
Volts:	230/460	P.F:	0.86	Volts:	190/380	Design:	B
Amps:	229.8/114.9	Eff:	0.954	Amps	278.2/139.1	DE BRG:	6316 C3
RPM:	1785	S.F:	1.25	RPM	1480	ODE BRG:	6313 C3
				S.F:	1.00	WT:	1151 lbs.