

DATA SHEET

Premium Efficiency Motor: **LAM400-36-L449TS**

60 Hz

WorldWide Electric Corporation

1 (800) 808-2131

Worldwideelectric.net



Document Generated: 8-Sep-2023
Document ID:

Customer:

MOTOR INFORMATION	
HP	400
RPM	3600
Phase	3
Frequency	60 Hz
Voltage	460
Frame Size	L447/9TS
Enclosure	TEFC
Degree of Protection	IP55
Service Factor	1.15
Poles	2
Full Load Speed	3590
Insulation Class	F
Temp Rise	80°C
NEMA Code Letter	G
Duty Cycle	S1 / Continuous
Slip	0.33%
NEMA Design	B
Moment of Inertia	78.8 lb.ft.^2
Locked Rotor Time (Hot)	12 seconds
Sound Pressure Level	110 dB(A)
Number of Starts	2 Cold/1 Hot
Max Ambient Temperature	40°C
Max Elevation	1000 m.a.s.l (3300 f.a.s.l)
Mounting	Rigid
Rotation	Bi-Directional
Area of Classification	Class 1 Division 2 Groups A,B,C,D T3B
Inverter Rating	10:1 CT / 20:1 VT
Standard	NEMA MG-1
Approvals	UL, CE, IEEE45, ABS

EFFICIENCY/POWER FACTOR		
LOAD	EFF	P. F.
100%	95.8 %	0.93
75%	95.8 %	0.92
50%	95.1 %	0.88

TORQUE		
FULL LOAD	LRT	BDT
586.4 lb.ft.	204 %	345 %

AMPERAGE INFORMATION		
	230V	460V
Full Load Amps	--A	421.3A
Locked Rotor Amps	--A	3113A
No Load Current	--A	87.2A
Usable at 208V		-- A

BEARING INFORMATION	
DE Bearing	6320 C3
ODE Bearing	6320 C3
Grease Type	Mobil Polyrex EM
DE Regreasing Interval	2400 Hours
ODE Regreasing Interval	2400 Hours
Grease Quantity	51g/51g

ADDITIONAL DATA	
F2 Suitable	Yes
Shaft Material	4140
Connection Diagram	6 Lead Delta
Approximate Weight	lbs.

MOTOR DRAWING

Premium Efficiency Motor: **LAM400-36-L449TS**

WorldWide Electric Corporation

1 (800) 808-2131

Worldwideelectric.net

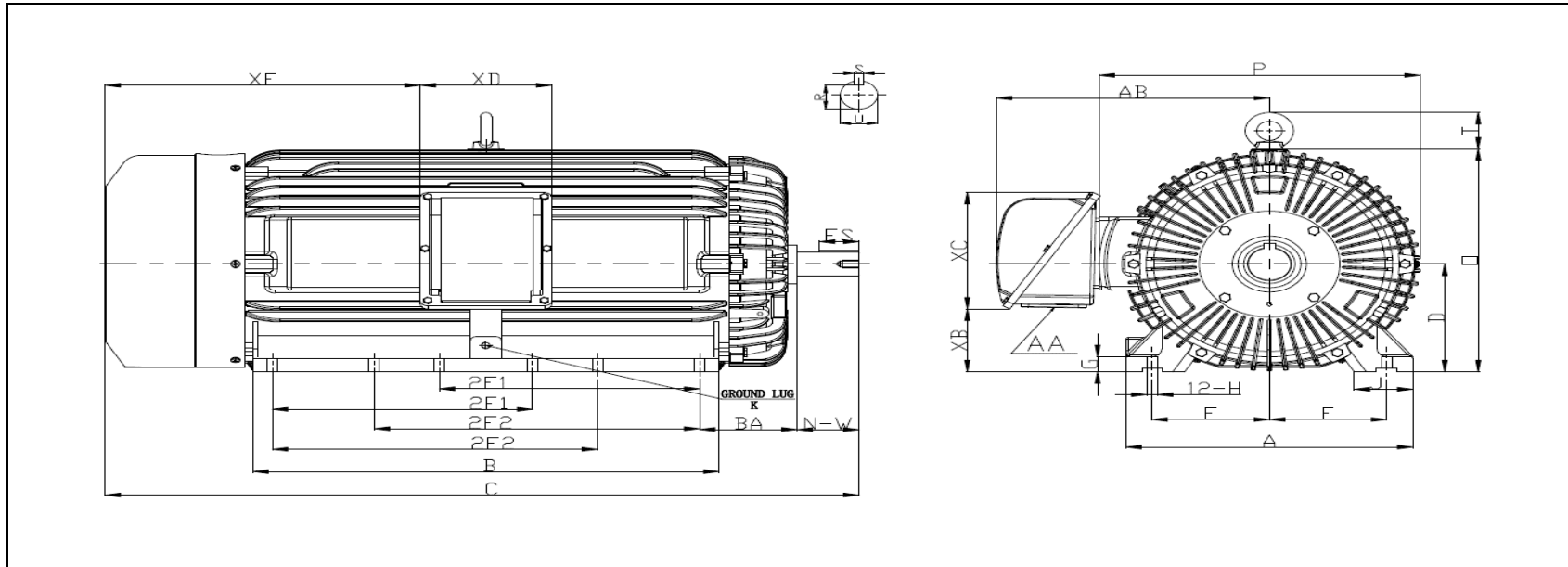

DIMENSION - INCHES

MOUNTING					A	B	C	D	G	J	P	O	T	AB
E	2F1	2F2	H	BA										
9	20	25	0.81	7.5	22	29	58.6	11	1.417	4.33	25.8	23.8	4.85	23.4

SHAFT & KEY				
S	ES	R	N-W	U
0.625	3.03	2.021	4.75	2.375

TERMINAL BOX				
AA	XB	XC	XD	XE
3 NPT	4.13	16.2	11.6	23.2

GROUND LUG
M12

PERFORMANCE CURVES

WorldWide Electric Corporation

1 (800) 808-2131

Worldwideelectric.net



Premium Efficiency Motor:

LAM400-36-L449TS

Document Generated: 8-Sep-2023	Customer:
Document ID:	

Motor Type	AEH3		FL Speed	3590	
Output Rating (HP)	400		LRT (%FLT)	204	
Full Load Torque	586.4	lb.ft	460 volt FLA	421.3	
Rotor Wk ²	78.8	lb-ft ²	230 volt FLA	--	
			BDT (%FLT)	345	

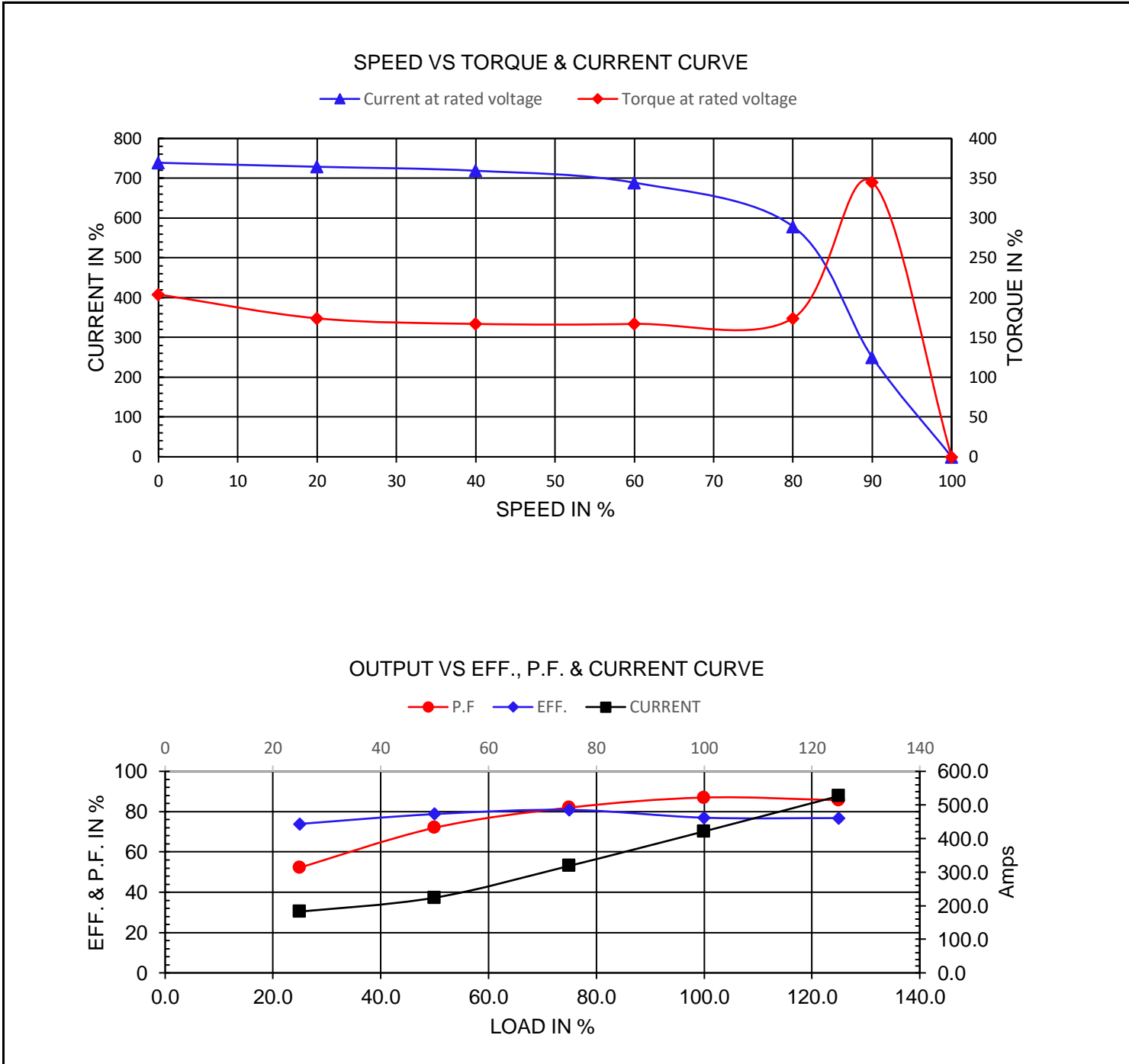

NAMEPLATE / WIRING

Premium Efficiency Motor: **LAM400-36-L449TS**

WorldWide Electric Corporation

1 (800) 808-2131

Worldwideelectric.net



Document Generated: 8-Sep-2023
Document ID:

Customer:

SAMPLE NAMEPLATE DATA

		THREE PHASE SEVERE DUTY MOTOR IEEE45							
Model :		Encl :	Type :		SN :				
HP :	Poles :	FR:	Ins:	Duty: Cont	IP :	Max Amb 40°C			
Hz :		CODE :		Hz :	HP :	Design :			
Volts :		P.F :		Volts :		DE BRG :			
Amps :		Eff :		Amps :		ODE BRG :			
RPM :		S.F :		RPM :		WT :			
S.F :				S.F :		Date :			
CC306B					LOUIS ALLIS A WORLDWIDE ELECTRIC COMPANY				UL certified Class I, Division II, Groups A,B,C,D T3B

Model:	LAM400-36-L449TS	Encl:	TEFC	Type:	AEH3
HP:	400	Poles	2	FR:	L447/9TS
Hz:	60	CODE:	G	Ins:	F
Volts:	460	P.F:	0.93	HP:	350
Amps:	421.3	Eff:	0.958	Design:	B
RPM:	3590	S.F:	1.15	DE BRG:	6320 C3
				ODE BRG:	6320 C3
				WT:	lbs.
				S.F:	1.00