

MOTOR DRAWING

Premium Efficiency Motor: **ODP-213/5TC**

WorldWide Electric Corporation

1 (800) 808-2131

Worldwideelectric.net

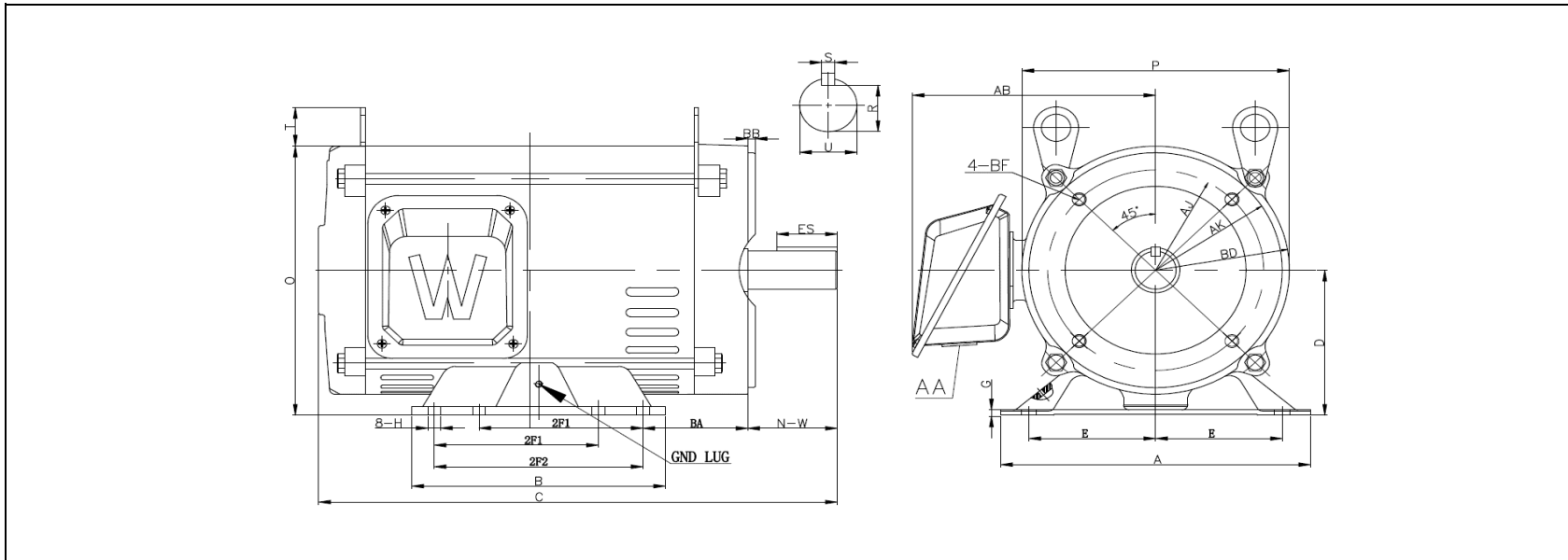

DIMENSION - INCHES

MOUNTING					A	B	C	D	G	P	O	T	AB
E	2F1	2F2	H	BA									
4.25	5.5	7	0.43	3.5	9.69	8.19	17.8	5.25	0.16	9.4	9.8	1.5	8.16

SHAFT & KEY				
S	ES	R	N-W	U
0.31	2.41	1.201	3.38	1.375

T-BOX	GND LUG
AA	M6*P1.0
1.38	

FLANGE				
AK	BD	AJ	BF	BB
8.5	9	7.25	4*1/2-13 UNC	0.25