

MOTOR DRAWING

Premium Efficiency Motor: **ODP-404/5TC**

WorldWide Electric Corporation

1 (800) 808-2131

Worldwideelectric.net

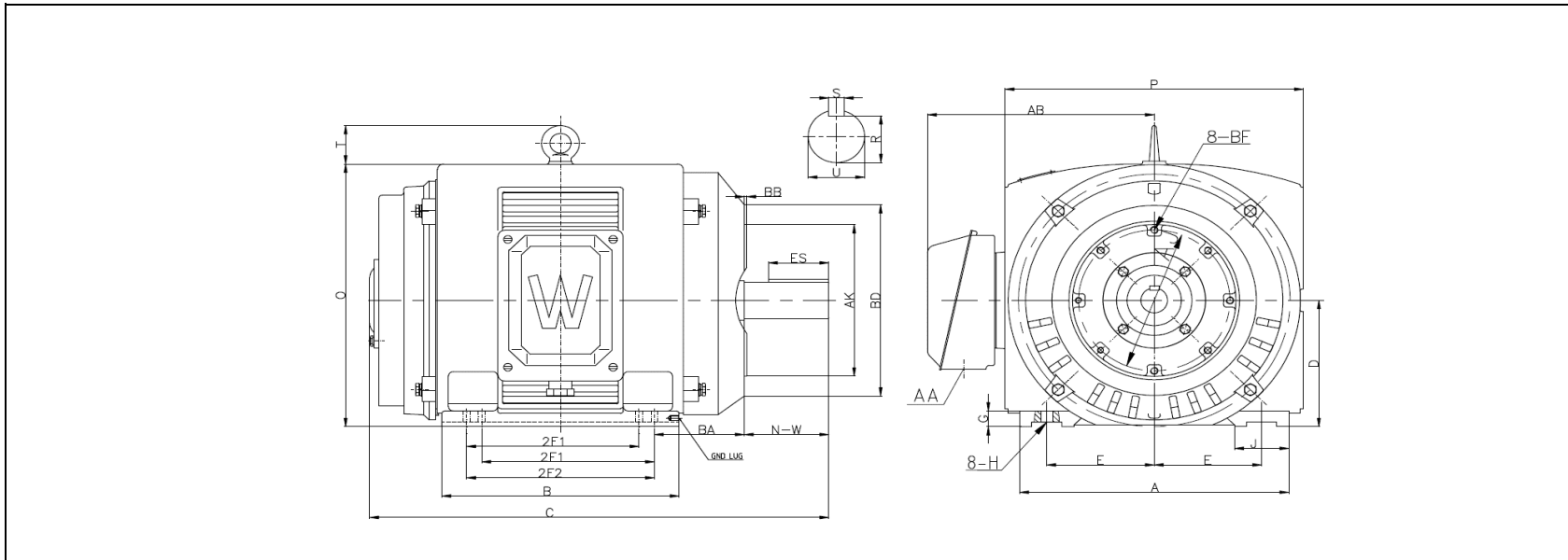

DIMENSION - INCHES

MOUNTING					A	B	C	D	G	P	O	T	AB
E	2F1	2F2	H	BA									
8	12.25	13.75	0.81	6.62	20	17.6	33.7	10	1.18	21.3	20.3	3	16.93

SHAFT & KEY				
S	ES	R	N-W	U
0.75	5.65	2.45	7.25	2.875

T-BOX	GND LUG
AA	
3	M12*P1.75

FLANGE				
AK	BD	AJ	BF	BB
12.5	15.5	11	8*5/8-11 UNC	0.25