

DATA SHEET

Premium Efficiency Motor: **ODP15-36-215TC,**

60 Hz

WorldWide Electric Corporation

1 (800) 808-2131

Worldwideelectric.net



Document Generated: 11-Dec-2023
Document ID:

Customer:

MOTOR INFORMATION	
HP	15
RPM	3600
Phase	3
Frequency	60
Voltage	230/460
Frame Size	213/5TC
Enclosure	ODP
Degree of Protection	IP23
Service Factor	1.15
Poles	2
Full Load Speed	3482
Insulation Class	F
Temp Rise	80°C
NEMA Code Letter	G
Duty Cycle	S1 / Continuous
Slip	3.29%
NEMA Design	B
Moment of Inertia	0.542 lb.ft.^2
Locked Rotor Time (Hot)	12 seconds
Sound Pressure Level	67 dB(A)
Number of Starts	2 Cold / 1 Hot
Max Ambient Temperature	40°C
Max Elevation	1000 m.a.s.l (3300 f.a.s.l)
Mounting	F1
Rotation	Bi-Directional
Area of Classification	Safe Area
Inverter Rating	10:1 CT / 20:1 VT
Standard	NEMA MG 1
Approvals	UL, CE

EFFICIENCY/POWER FACTOR		
LOAD	EFF	P. F.
100%	90.2 %	0.89
75%	91.7 %	0.88
50%	92.2 %	0.84

TORQUE		
FULL LOAD	LRT	BDT
22.08 lb.ft.	337 %	385 %

AMPERAGE INFORMATION		
	230V	460V
Full Load Amps	34.2A	17.1A
Locked Rotor Amps	234.4A	117.2A
No Load Current	7.46A	3.73A
Usable at 208V	18.91A	

BEARING INFORMATION	
DE Bearing	6308ZZ
ODE Bearing	6306ZZ
Grease Type	NSK SN7
DE Regreasing Interval	-- Hours
ODE Regreasing Interval	-- Hours
Grease Quantity	--

ADDITIONAL DATA	
F2 Suitable	No
Shaft Material	AISI 1045
Connection Diagram	9 Lead Wye
Approximate Weight	142 lbs.

MOTOR DRAWING

Premium Efficiency Motor: **ODP15-36-215TC**

WorldWide Electric Corporation

1 (800) 808-2131

Worldwideelectric.net

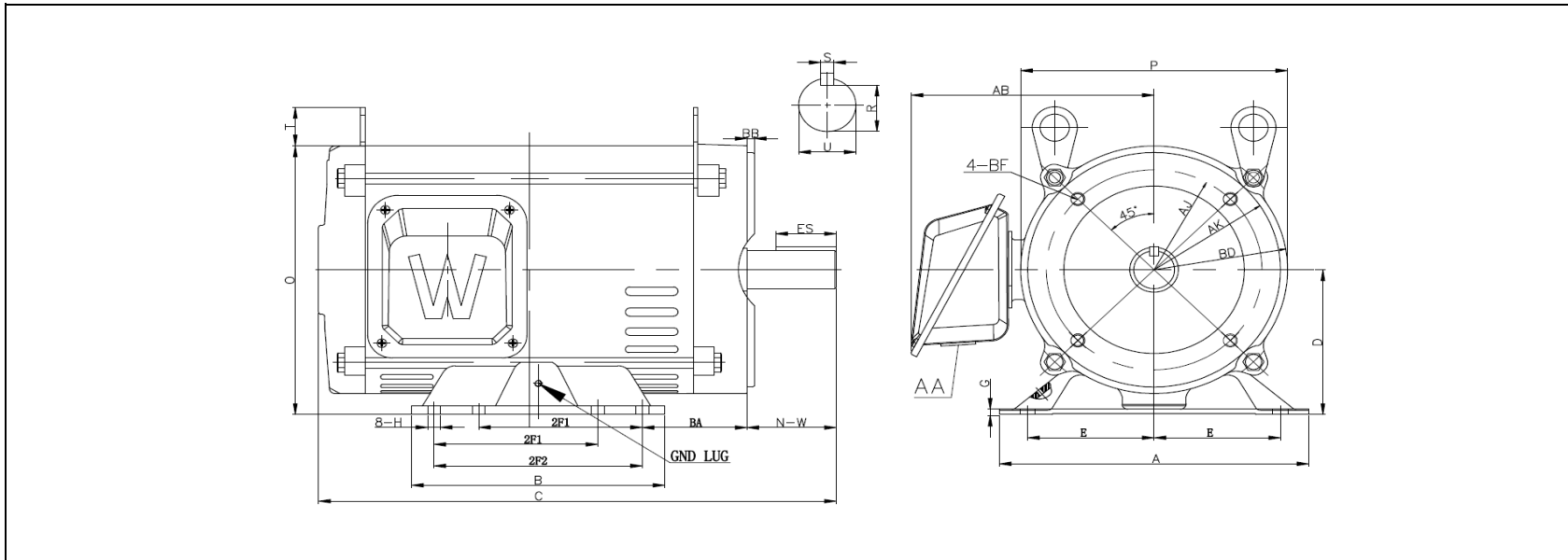

DIMENSION - INCHES

MOUNTING					A	B	C	D	G	P	O	T	AB
E	2F1	2F2	H	BA									
4.25	5.5	7	0.43	3.5	9.69	8.19	17.8	5.25	0.16	9.4	9.8	1.5	8.16

SHAFT & KEY				
S	ES	R	N-W	U
0.31	2.41	1.201	3.38	1.375

T-BOX	GND LUG
AA	M6*P1.0
1.38	

FLANGE				
AK	BD	AJ	BF	BB
8.5	9	7.25	4*1/2-13 UNC	0.25

PERFORMANCE CURVES

WorldWide Electric Corporation

1 (800) 808-2131

Worldwideelectric.net



Premium Efficiency Motor:

ODP15-36-215TC

Document Generated: 11-Dec-2023
Document ID:

Customer:

Motor Type	ODP		FL Speed	3482	
Output Rating (HP)	15		LRT (%FLT)	337	
Full Load Torque	22.08	lb.ft	460 volt FLA	17.1	
Rotor Wk ²	0.902	lb-ft ²	230 volt FLA	34.2	
			BDT (%FLT)	385	

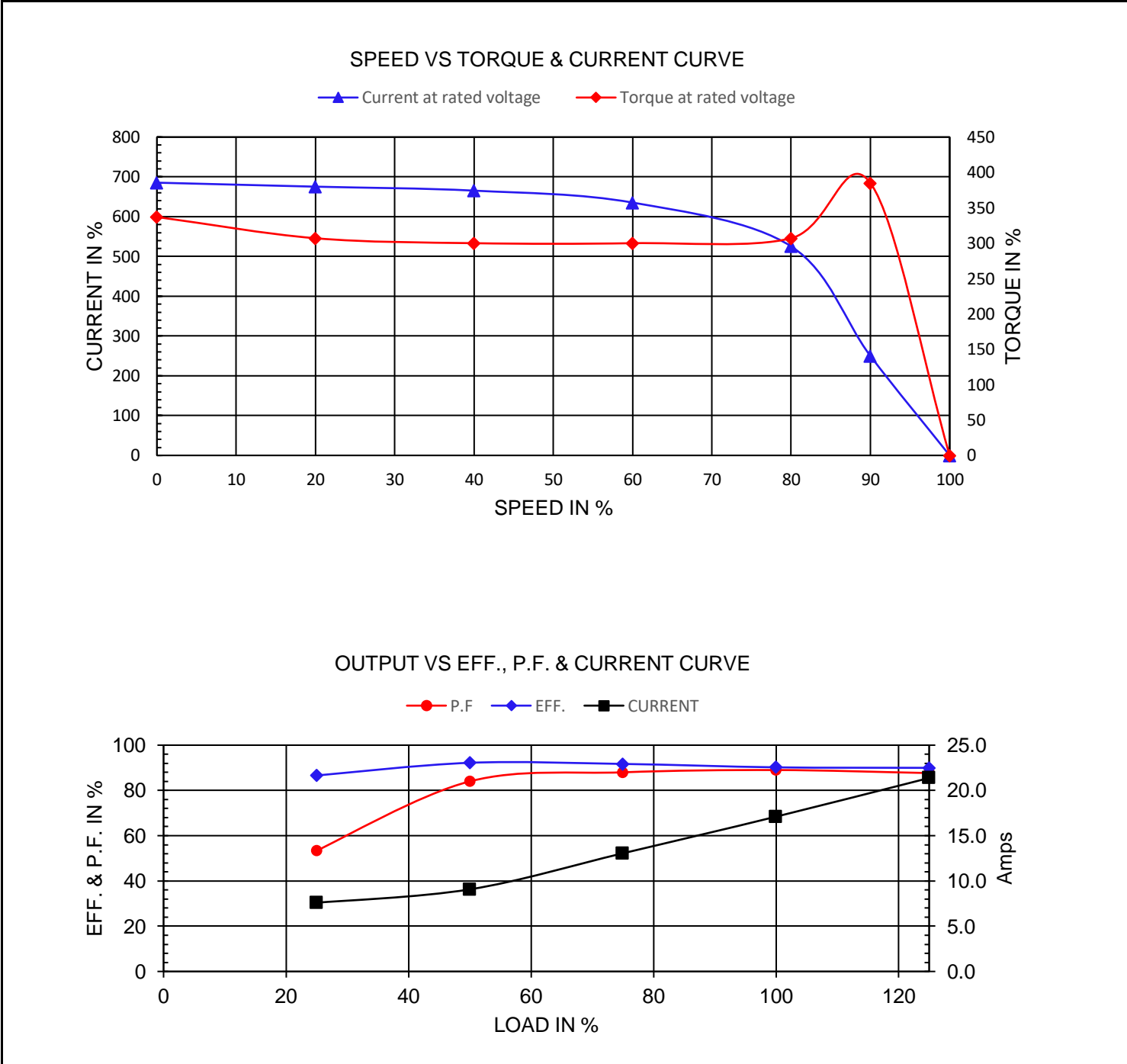

NAMEPLATE / WIRING

WorldWide Electric Corporation

1 (800) 808-2131

Worldwideelectric.net



Premium Efficiency Motor: **ODP15-36-215TC**

Document Generated: 11-Dec-2023
Document ID:

Customer:

SAMPLE NAMEPLATE DATA

		OPEN DRIP PROOF 3 PHASE MOTOR									
Model :		Encl : ODP		SN :						4 5 6 	
HP :	Poles :	FR :	Ins : F	IP 23	Max Amb 40°C	Duty : Cont					
Hz : 60	CODE:		Hz : 50	Design : B		7 8 9 1 2 3 L1 L2 L3		230 V			
Volts : 230/460	P.F. :		Volts : 190/380		DE BRG :		4 5 6 7 8 9 1 2 3 L1 L2 L3		460 V		
Amps :	Eff: %		Amps :	ODE BRG :		WT: LBS					
RPM :	S.F. : 1.15		RPM :	Date :							
WorldWide Electric Corporation											

Model: ODP15-36-215TC		Encl: ODP									
HP: 15	Poles: 2	Frame 213/5TC	Ins Cl: F	IP IP23							
Hz: 60	Code: G	Hz: 50	Design: B								
Volts: 230/460	P.F.: 0.89	Volts: 190/380	DE Brg: 6308ZZ								
Amps: 34.2/17.1	Eff: 90.2%	Amps: 38.8/19.4	ODE Brg: 6306ZZ								
RPM: 3482	S.F.: 1.15	RPM: 2555	WT: 142 lbs.								
		S.F.: 1.0									