



PE143JP-1.5-2

CLOSE COUPLED PUMP MOTORS

NEMA PREMIUM EFFICIENCY

TOTALLY ENCLOSED FAN COOLED, JP FRAME

INVERTER DUTY 10:1 CT; 20:1 VT - NEMA MG1 PART 31

Factory Certified for T2B Class I, Division II, Groups A,B,C & D and Class II, Division II, Groups F & G

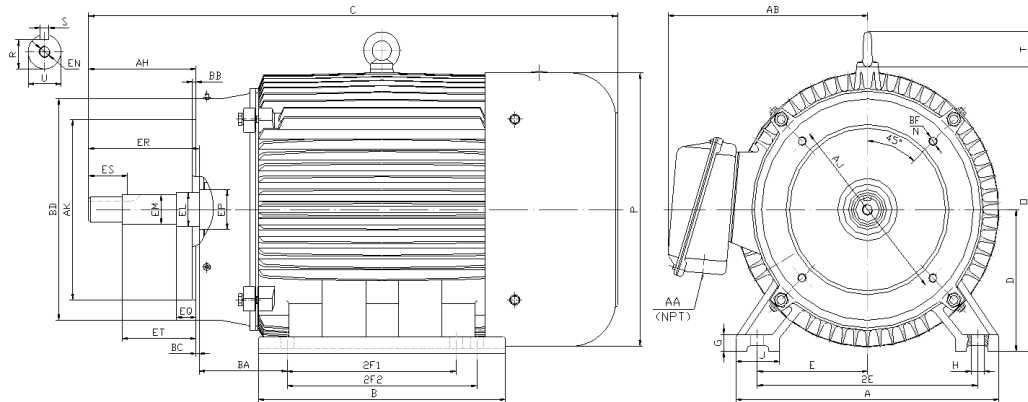

DIMENSIONS

HP	RPM	Frame	MOUNTING														
			A	B	C	D	G	H	J	E	2E	2F1	2F2	O	P	T	BA
1.5	3600	143JP	7	6.2	19.3	3.5	0.5	0.34	1.4	2.75	5.5	4	5	7.1	6.95	NA	2.75

FLANGE							Shaft Extension, Key Set										
AH	AJ	AK	BB	BC	BD	BF	U	R	S	EQ	ER	ES	ET	EP	EL	EM	EN
7.343	5.875	4.500	0.156	0.12	6.62	4*3/8-16	0.8745	0.771	0.190	1.578	7.312	1.65	5.952	1.18	1.156	1.0000	3/8-16
7.281		4.497	0.125				0.8740	0.756	0.188	1.548			5.922		1.154	0.9995	

Conduit Box		Bearings		Mount
AA	AB	DE	ODE	
0.75	6.1	6206-ZZ	6205-ZZ	F1

BEARING LUBRICATION: The bearings come lubricated with Mobil Polyrex EM Polyurea Grease.





PE143JP-1.5-2

CLOSE COUPLED PUMP MOTORS

NEMA PREMIUM EFFICIENCY

TOTALLY ENCLOSED FAN COOLED, JP FRAME

INVERTER DUTY 10:1 CT; 20:1 VT - NEMA MG1 PART 31

Factory Certified for T2B Class I, Division II, Groups A,B,C & D and Class II, Division II, Groups F & G

PERFORMANCE DATA

HP	RPM	Frame	Voltage	Frequency (Hz)	Full Load S.F.	Insulation Class	NEMA Design	Slip (%)	NEMA Code	Enclosure Type	IP Rating	Max. Ambient
1.5	3520	143JP	230/460	60	1.15	F	B	2.2	M	TEFC	55	40 °C

Amps (460V)		Efficiency (%)			Power Factor			Torque (ft-lb)			DE Bearing	ODE Bearing	Connection	Weight (lbs.)
FLA	LRA	100%	75%	50%	100%	75%	50%	FLT	LRT %	BDT %	6206-ZZ	6205-ZZ	9 Lead 2Y/Y	47
2	20	84.0	82.0	77.0	0.74	0.66	0.54	2.2	200	280				

*Usable at 208 Volts

NAME PLATE

		AC INDUCTION MOTOR INVERTER DUTY 20:1 VT; 10:1 CT								CONNECTION DIAGRAMS		
CAT NO. PE143JP-1.5-2		FRAME 143JP		PHASE 3		230V						
HZ 60	S.F. 1.15	HZ 50	S.F. 1.0	ENCL TEFC	IP 55							
HP 1.5	RPM 3520	HP 1.5	RPM 2900	DUTY CONT	DES B							
VOLTS 230/460		VOLTS 190/380		AMB 40 °C	INS F							
AMPS 4/2		AMPS 5.2/2.6		DE BRG 6206-ZZ								
CODE M	P.F. 0.74	CODE K	P.F. 0.80	ODE BRG 6205-ZZ								
EFF 84.0	MIN 81.5	EFF 82.0	MIN 79.5	LUB: Mobil Polyrex EM					460V			
MOTOR WEIGHT 47 LBS		CONNECTION 9 Lead 2Y/Y		SER NO								
General purpose use on industrial machinery installed in damp, dusty or dirty environments. Hernando, Mississippi								CC082A				

APPLICATIONS:

Specifically designed for use on industrial and commercial pumping units.