



PE184JM-5-4

CLOSE COUPLED PUMP MOTORS

NEMA PREMIUM EFFICIENCY

TOTALLY ENCLOSED FAN COOLED, JM FRAME

INVERTER DUTY 10:1 CT; 20:1 VT - NEMA MG1 PART 31

Factory Certified for T2B Class I, Division II, Groups A,B,C & D and Class II, Division II, Groups F & G

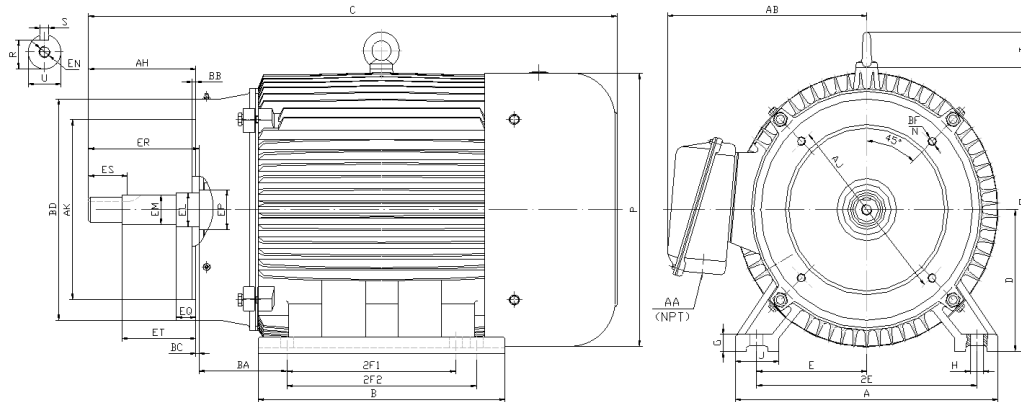

DIMENSIONS

HP	RPM	Frame	MOUNTING														
			A	B	C	D	G	H	J	E	2E	2F1	2F2	O	P	T	BA
5	1800	184JM	9.5	8.3	19.48	4.5	0.6	0.41	2	3.75	7.5	4.5	5.5	9.1	8.7	1.6	3.5

FLANGE							Shaft Extension, Key Set										
AH	AJ	AK	BB	BC	BD	BF	U	R	S	EQ	ER	ES	ET	EP	EL	EM	EN
4.281	5.875	4.500	0.156	0.12	6.62	4*3/8-16	0.8745	0.771	0.190	0.640	4.25	1.65	2.890	1.57	1.250	1.0000	3/8-16
4.219		4.497	0.125				0.8740	0.756	0.188	0.610			2.860		1.248	0.9995	

Conduit Box		Bearings		Mount
AA	AB	DE	ODE	
0.75	7.5	6208-ZZ	6306-ZZ	F1

BEARING LUBRICATION: The bearings come lubricated with Mobil Polyrex EM Polyurea Grease.





PE184JM-5-4

CLOSE COUPLED PUMP MOTORS

NEMA PREMIUM EFFICIENCY

TOTALLY ENCLOSED FAN COOLED, JM FRAME

INVERTER DUTY 10:1 CT; 20:1 VT - NEMA MG1 PART 31

Factory Certified for T2B Class I, Division II, Groups A,B,C & D and Class II, Division II, Groups F & G

PERFORMANCE DATA

HP	RPM	Frame	Voltage	Frequency (Hz)	Full Load S.F.	Insulation Class	NEMA Design	Slip (%)	NEMA Code	Enclosure Type	IP Rating	Max. Ambient
5	1755	184JM	230/460	60	1.15	F	B	2.5	J	TEFC	55	40 °C

Amps (460V)		Efficiency (%)			Power Factor			Torque (ft-lb)			DE Bearing	ODE Bearing	Connection	Weight (lbs.)
FLA	LRA	100%	75%	50%	100%	75%	50%	FLT	LRT %	BDT %				
6.8	46	89.5	89.8	89.0	0.78	0.74	0.62	15	185	280	6208-ZZ	6306-ZZ	9 Lead 2Y/Y	96

*Usable at 208 Volts

NAME PLATE

		AC INDUCTION MOTOR INVERTER DUTY 20:1 VT; 10:1 CT								CONNECTION DIAGRAMS		
CAT NO. PE184JM-5-4		FRAME 184JM		PHASE 3		230V						
HZ 60	S.F. 1.15	HZ 50	S.F. 1.0	ENCL TEFC	IP 55	T4		T5		T6		
HP 5	RPM 1755	HP 5	RPM 1440	DUTY CONT	DES B	T7		T8		T9		
VOLTS 230/460		VOLTS 190/380		AMB 40 °C	INS F	T1		T2		T3		
AMPS 13.6/6.8	AMPS 15.4/7.7		DE BRG 6208-ZZ		L1		L2		L3			
CODE J	P.F. 0.78	CODE H	P.F. 0.84	ODE BRG 6306-ZZ		460V						
EFF 89.5	MIN 87.5	EFF 87.5	MIN 85.5	LUB: Mobil Polyrex EM		T4		T5		T6		
MOTOR WEIGHT 96 LBS	CONNECTION 9 Lead 2Y/Y		SER NO		T7		T8		T9			
General purpose use on industrial machinery installed in damp, dusty or dirty environments. Hernando, Mississippi								CC082A		T1 T2 T3 L1 L2 L3		

APPLICATIONS:

Specifically designed for use on industrial and commercial pumping units.