



## PE256JM-20-2

CLOSE COUPLED PUMP MOTORS

NEMA PREMIUM EFFICIENCY

TOTALLY ENCLOSED FAN COOLED, JM FRAME

INVERTER DUTY 10:1 CT; 20:1 VT - NEMA MG1 PART 31

Factory Certified for T2B Class I, Division II, Groups A,B,C & D and Class II, Division II, Groups F & G

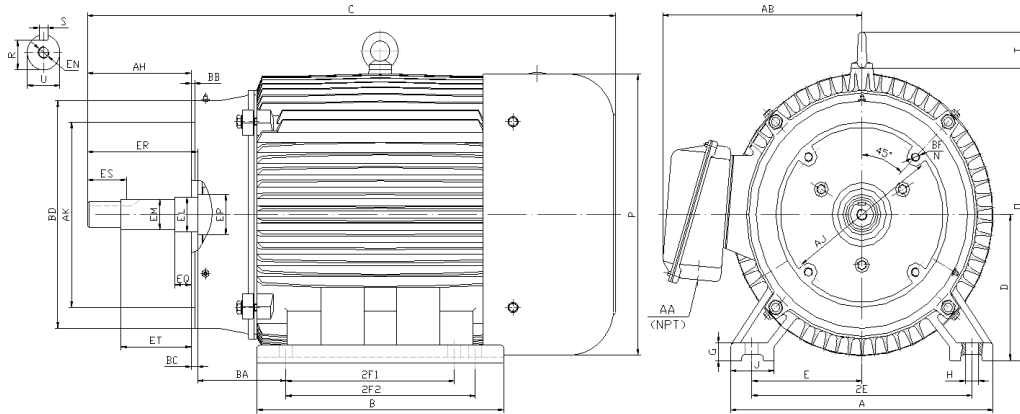

### DIMENSIONS

HP	RPM	Frame	MOUNTING														
			A	B	C	D	G	H	J	E	2E	2F1	2F2	O	P	T	BA
20	3600	256JM	13	12.2	26.5	6.25	0.7	0.53	2.75	5	10	8.25	10	13	12.4	2.2	4.75

FLANGE							Shaft Extension, Key Set										
AH	AJ	AK	BB	BC	BD	BF	U	R	S	EQ	ER	ES	ET	EP	EL	EM	EN
5.281	7.25	8.500	0.312	0.25	10	4*1/2-13	1.2495	1.112	0.252	0.640	5.25	2.53	3.015	1.77	1.750	1.3750	1/2-13
5.219		8.497	0.250				1.2490	1.097	0.250	0.610			2.985		1.748	1.3745	

Conduit Box		Bearings		Mount
AA	AB	DE	ODE	
1.25	10.1	6309	6309	F1

**BEARING LUBRICATION:** The bearings come lubricated with Mobil Polyrex EM Polyurea Grease. It is recommended that you add some additional lubrication when the motor is installed.

Three options (brands) for suitable lubrication include, but are not limited to, the following:

- 1.) Mobil Polyrex EM
- 2.) Citco Polyurea MP
- 3.) Conoco Phillips Polytac EP





## PE256JM-20-2

CLOSE COUPLED PUMP MOTORS

NEMA PREMIUM EFFICIENCY

TOTALLY ENCLOSED FAN COOLED, JM FRAME

INVERTER DUTY 10:1 CT; 20:1 VT - NEMA MG1 PART 31

Factory Certified for T2B Class I, Division II, Groups A,B,C & D and Class II, Division II, Groups F & G

### PERFORMANCE DATA

HP	RPM	Frame	Voltage	Frequency (Hz)	Full Load S.F.	Insulation Class	NEMA Design	Slip (%)	NEMA Code	Enclosure Type	IP Rating	Max. Ambient
20	3540	256JM	230/460	60	1.15	F	B	1.7	G	TEFC	55	40 °C

Amps (460V)		Efficiency (%)			Power Factor			Torque (ft-lb)			DE Bearing	ODE Bearing	Connection	Weight (lbs.)
FLA	LRA	100%	75%	50%	100%	75%	50%	FLT	LRT %	BDT %				
23	145	91.0	91.0	90.0	0.87	0.85	0.79	29.76	150	250	6309	6309	12 Lead 2Δ/Δ	288

\*Usable at 208 Volts

### NAME PLATE

		AC INDUCTION MOTOR INVERTER DUTY 20:1 VT; 10:1 CT								CONNECTION DIAGRAMS 230V				
CAT NO. PE256JM-20-2		FRAME 256JM		PHASE 3										
HZ 60	S.F. 1.15	HZ 50	S.F. 1.0	ENCL TEFC	IP 55									
HP 20	RPM 3540	HP 20	RPM 2920	DUTY CONT	DES B									
VOLTS 230/460		VOLTS 190/380		AMB 40 °C	INS F									
AMPS 46/23		AMPS 57/28.5		DE BRG 6309										
CODE G	P.F. 0.87	CODE E	P.F. 0.89	ODE BRG 6309										
EFF 91.0	MIN 89.5	EFF 89.0	MIN 87.5	LUB: Mobil Polyrex EM										
MOTOR WEIGHT 288 LBS		CONNECTION 12 Lead 2Δ/Δ		SER NO										
General purpose use on industrial machinery installed in damp, dusty or dirty environments. Hernando, Mississippi								CC082A						

### APPLICATIONS:

Specifically designed for use on industrial and commercial pumping units.