

PES145TC3M-2-A

WASHDOWN DUTY MOTOR
NEMA PREMIUM EFFICIENCY
STAINLESS STEEL CONSTRUCTION - C-FLANGE WITH FEET
TOTALLY ENCLOSED FAN COOLED - IP66 CONSTRUCTION
INVERTER DUTY 10:1 CT; 20:1 VT - NEMA MG1 PART 31

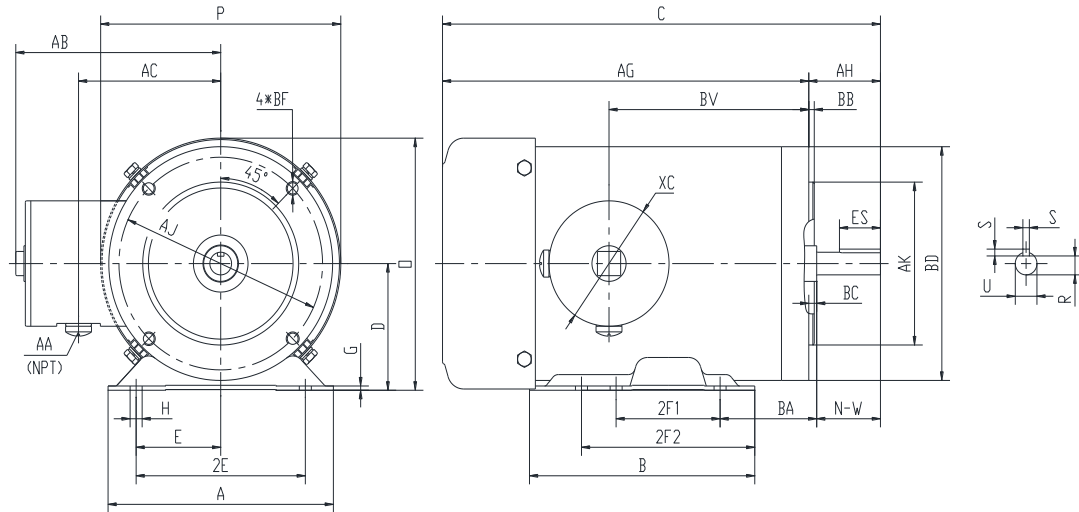

DIMENSIONS

HP	RPM	Frame	MOUNTING													
			A	B	C	D	G	H	E	2E	2F1	2F2	O	P	AG	BA
3	3600	145TC	6.5	6.5	15.58	3.5	0.118	1.22*0.34	2.75	5.5	3	5	6.98	6.95	13.46	2.75

FLANGE						Shaft Extension, Key Set					Conduit Box				
AH	AJ	AK	BB	BC	BF	U	R	S	ES	N-W	AA	AB	AC	BV	
2.12	5.875	4.5	0.16	0.12	4*3/8-16	0.875	0.771	0.188	1.41	2.25	0.5	5.95	4.5	6.95	

Bearings		Mount
DE	ODE	
6205-2RS	6205-2RS	F1

BEARING LUBRICATION: The bearings come lubricated with Mobil Polyrex EM Polyurea Grease.



PESS145TC3M-2-A

WASHDOWN DUTY MOTOR
NEMA PREMIUM EFFICIENCY
STAINLESS STEEL CONSTRUCTION - C-FLANGE WITH FEET
TOTALLY ENCLOSED FAN COOLED - IP66 CONSTRUCTION
INVERTER DUTY 10:1 CT; 20:1 VT - NEMA MG1 PART 31

PERFORMANCE DATA

HP	RPM	Frame	Voltage	Frequency (Hz)	Full Load S.F.	Insulation Class	NEMA Design	Slip (%)	NEMA Code	Enclosure Type	IP Rating	Max. Ambient
3	3510	145TC	230/460	60	1.15	F	B	2.5	K	TEFC	66	40 °C

Amps (460V)		Efficiency (%)			Power Factor			Torque (ft-lb)			DE Bearing	ODE Bearing	Connection	Weight (lbs.)
FLA	LRA	100%	75%	50%	100%	75%	50%	FLT	LRT %	BDT %				
4.1	32	86.5	87.0	86.0	0.87	0.81	0.70	4.4	250	285	6205-2RS	6205-2RS	9 Lead 2Y/Y	60

*Usable at 208 Volts

NAME PLATE

		THREE PHASE AC INDUCTION MOTOR INVERTER DUTY 20:1 VT; 10:1 CT										Hernando, MS 38632	
		Model :		PESS145TC3M-2-A				IP 66		FRAME 145TC		LB/WT 60	
HZ 60		S.F. 1.15		HZ 50		S.F. 1.0		NEMA DESIGN B					
HP 3		RPM 3510		HP 3		RPM 2930		ENCL. TEFC		INS F			
VOLTS 230/460				VOLTS 190/380				DUTY CONT		AMB 40 °C			
AMPS 8.2/4.1				AMPS 9/4.5				DE BRG 6205-2RS					
CODE K		P.F. 0.87		CODE H		P.F. 0.90		ODE BRG 6205-2RS					
EFF 86.5		MIN 84.0		EFF 85.5		MIN 83.0		SER NO.					
230V 		460V 								CC082A MADE IN CHINA			

Factory Certified for T2B
 Div 2. Class I, Gr. A , B , C & D
 and Class II, Gr. F & G

APPLICATIONS:

Applications include washdown applications, food processing, chemical processing, pharmaceuticals, poultry processing, meat processing, dairy applications, bakeries, snack foods, bottling and extremely corrosive environments.