

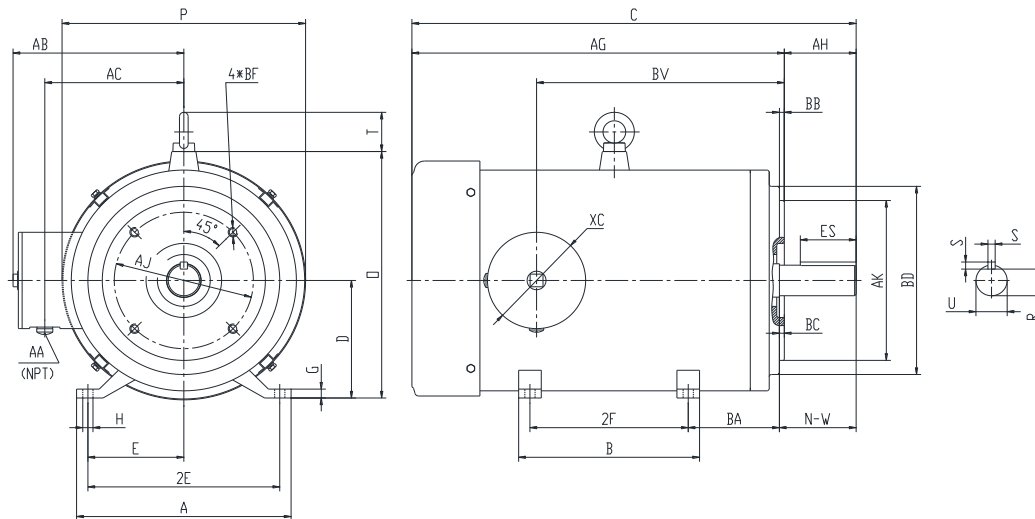

PES256TC20M-4-A

**WASHDOWN DUTY MOTOR
 NEMA PREMIUM EFFICIENCY
 STAINLESS STEEL CONSTRUCTION - C-FLANGE WITH FEET
 TOTALLY ENCLOSED FAN COOLED - IP66 CONSTRUCTION
 INVERTER DUTY 10:1 CT; 20:1 VT - NEMA MG1 PART 31**



DIMENSIONS

HP	RPM	Frame	MOUNTING														
			A	B	C	D	G	H	E	2E	2F1	2F2	O	P	T	AG	BA
20	1800	256TC	11.2	11.25	24.8	6.25	0.475	0.53	5	10	NA	10	13.1	12.7	2.1	21.05	4.75

FLANGE						Shaft Extension, Key Set					Conduit Box				
AH	AJ	AK	BB	BC	BF	U	R	S	ES	N-W	AA	AB	AC	BV	
3.75	7.25	8.5	0.25	0.25	4*1/2-13	1.625	1.416	0.375	2.91	4	0.75	8.9	7.25	14.25	

Bearings		Mount
DE	ODE	
6309-2RS	6309-2RS	F1

BEARING LUBRICATION: The bearings come lubricated with Mobil Polyrex EM Polyurea Grease.





PESS256TC20M-4-A

WASHDOWN DUTY MOTOR
NEMA PREMIUM EFFICIENCY
STAINLESS STEEL CONSTRUCTION - C-FLANGE WITH FEET
TOTALLY ENCLOSED FAN COOLED - IP66 CONSTRUCTION
INVERTER DUTY 10:1 CT; 20:1 VT - NEMA MG1 PART 31

PERFORMANCE DATA

HP	RPM	Frame	Voltage	Frequency (Hz)	Full Load S.F.	Insulation Class	NEMA Design	Slip (%)	NEMA Code	Enclosure Type	IP Rating	Max. Ambient
20	1765	256TC	230/460	60	1.15	F	B	1.9	G	TEFC	66	40 °C

Amps (460V)		Efficiency (%)			Power Factor			Torque (ft-lb)			DE Bearing	ODE Bearing	Connection	Weight (lbs.)
FLA	LRA	100%	75%	50%	100%	75%	50%	FLT	LRT %	BDT %				
24.5	145	93.0	92.5	92.0	0.88	0.75	0.63	58.6	200	250	6309-2RS	6309-2RS	12 Lead 2Δ/Δ	352

*Usable at 208 Volts

NAME PLATE

		THREE PHASE AC INDUCTION MOTOR INVERTER DUTY 20:1 VT; 10:1 CT						Hernando, MS 38632					
Model :		PESS256TC20M-4-A				IP	66	FRAME	256TC	LB/WT	352		
HZ	60	S.F.	1.15	HZ	50	S.F.	1.0	NEMA DESIGN		B			
HP	20	RPM	1765	HP	20	RPM	1465	ENCL.	TEFC	INS	F		
VOLTS		230/460			VOLTS		190/380		DUTY	CONT	AMB 40 °C		
AMPS		49/24.5			AMPS		58/29		DE BRG		6309-2RS		
CODE	G	P.F.	0.88	CODE	G	P.F.	0.90	ODE BRG		6309-2RS			
EFF	93.0	MIN	91.5	EFF	91.5	MIN	89.5	SER NO.					
								 C 272709		 E310089		CC082A MADE IN CHINA	

Factory Certified for T2B
 Div 2. Class I, Gr. A , B , C & D
 and Class II, Gr. F & G

APPLICATIONS:

Applications include washdown applications, food processing, chemical processing, pharmaceuticals, poultry processing, meat processing, dairy applications, bakeries, snack foods, bottling and extremely corrosive environments.