

PES182TC3M-2-B

WASHDOWN DUTY MOTOR WITH ENCAPSULATION
 NEMA PREMIUM EFFICIENCY
 STAINLESS STEEL CONSTRUCTION - C-FLANGE WITH FEET
 TOTALLY ENCLOSED FAN COOLED - IP66 CONSTRUCTION
 INVERTER DUTY 10:1 CT; 20:1 VT - NEMA MG1 PART 31

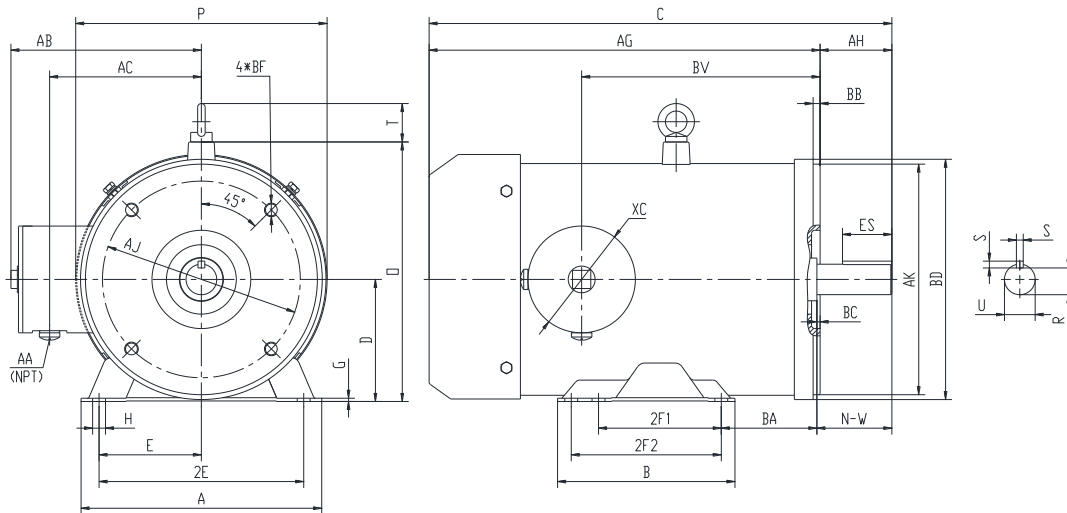

DIMENSIONS

HP	RPM	Frame	MOUNTING														
			A	B	C	D	G	H	E	2E	2F1	2F2	O	P	T	AG	BA
3	3600	182TC	8.8	6.5	17	4.5	0.118	0.71*0.47	3.75	7.5	4.5	5.5	9.55	9.25	1.45	14.38	3.5

FLANGE						Shaft Extension, Key Set					Conduit Box				
AH	AJ	AK	BB	BC	BF	U	R	S	ES	N-W	AA	AB	AC	BV	
2.62	7.25	8.5	0.25	0.12	4*1/2-13	1.125	0.986	0.25	1.78	2.75	0.5	7	5.55	8.5	

Bearings		Mount
DE	ODE	
6308-2RS	6306-2RS	F1

BEARING LUBRICATION: The bearings come lubricated with Mobil Polyrex EM Polyurea Grease.





PESS182TC3M-2-B

WASHDOWN DUTY MOTOR WITH ENCAPSULATION
NEMA PREMIUM EFFICIENCY
STAINLESS STEEL CONSTRUCTION - C-FLANGE WITH FEET
TOTALLY ENCLOSED FAN COOLED - IP66 CONSTRUCTION
INVERTER DUTY 10:1 CT; 20:1 VT - NEMA MG1 PART 31





PERFORMANCE DATA

HP	RPM	Frame	Voltage	Frequency (Hz)	Full Load S.F.	Insulation Class	NEMA Design	Slip (%)	NEMA Code	Enclosure Type	IP Rating	Max. Ambient
3	3510	182TC	230/460	60	1.15	F	B	2.5	K	TEFC	66	40 °C

Amps (460V)		Efficiency (%)			Power Factor			Torque (ft-lb)			DE Bearing	ODE Bearing	Connection	Weight (lbs.)
FLA	LRA	100%	75%	50%	100%	75%	50%	FLT	LRT %	BDT %				
4.05	32	86.5	87.0	86.0	0.89	0.75	0.63	4.4	270	290	6308-2RS	6306-2RS	9 Lead 2Y/Y	77

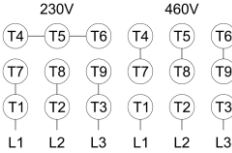
*Usable at 208 Volts

NAME PLATE

		THREE PHASE AC INDUCTION MOTOR INVERTER DUTY 20:1 VT; 10:1 CT						Hernando, MS 38632			
Model :		PESS182TC3M-2-B				IP	66	FRAME	182TC	LB/WT	77
HZ	60	S.F.	1.15	HZ	50	S.F.	1.0	NEMA DESIGN		B	
HP	3	RPM	3510	HP	3	RPM	2930	ENCL.	TEFC	INS	F
VOLTS		230/460		VOLTS		190/380		DUTY	CONT	AMB	40 °C
AMPS		8.1/4.05		AMPS		9/4.5		DE BRG		6308-2RS	
CODE	K	P.F.	0.89	CODE	K	P.F.	0.91	ODE BRG		6306-2RS	
EFF	86.5	MIN	84.0	EFF	84.0	MIN	81.5	SER NO.			
								CC082A		MADE IN CHINA	

Factory Certified for T2B
 Div 2. Class I, Gr. A , B , C & D
 and Class II, Gr. F & G

APPLICATIONS:

Applications include washdown applications, food processing, chemical processing, pharmaceuticals, poultry processing, meat processing, dairy applications, bakeries, snack foods, bottling and extremely corrosive environments.