



The **69M** pressure switch is used to regulate tank pressure between two preset valves on small (up to 175 psi) electrically driven air compressors. Unloader valve to prevent compressors from starting under load and auto-off disconnect lever for manual cut off are optional. A four port manifold which provides easy relief valve and gauge mounting is also available.

The rugged **69H** pressure switch is designed for the demanding requirements of larger, heavy duty commercial compressors (up to 250 psi). Sturdy painted steel case and cover resists the harsh conditions encountered in industrial applications. An unloader valve is also available on the 69H.

69M Switch Features Include:

- 3 and 5 HP 175 PSI maximum
- Corrosion resistant non-metallic cover
- 1/4 Female NPT

69H Switch Features Include:

- 5 Hp 250 PSI max.
- Rugged steel case and cover
- 3/8 Female NPT

Both Switches Feature:

- Easy adjustment
- No drift pressure settings
- Ample wiring room. 2 ground screws
- Visible contacts
- UL listed file #E14861
- CSA certified file LR36854
- Automatic unloader valve available

69M for Air Systems

Min. Close Cut-In	Max. Open Cut-Out	Differential Range	Pressure Setting Adjustment Table	Horsepower				Factory Setting	NEMA 1 General Purpose Cat No.
				1 Phase		3 Phase			
				120V	240V	240V	480/600V		
25 psi	100 psi	20-40 psi	E	1.5	2.0	3.0	–	80-100	69MB6
25 psi	100 psi	20-40 psi	E	2.0	3.0	5.0	1.0	80-100	69MC6
40 psi	150 psi	30-40 psi	F	1.5	2.0	3.0	–	95-125	69MB7
40 psi	150 psi	30-40 psi	F	2.0	3.0	5.0	1.0	95-125	69MC7
50 psi	175 psi	35-55 psi	G	1.5	2.0	3.0	–	115-150	69MB8
50 psi	175 psi	35-55 psi	G	2.0	3.0	5.0	1.0	115-150	69MC8

69H for Air Systems

Min. Close Cut-In	Max. Open Cut-Out	Differential Range	Pressure Adjustment Table	Horsepower				Factory Setting	NEMA 1 General Purpose Cat No.	NEMA 1—with Unloader Valve Cat. No.
				1 Phase		3 Phase				
				120V	240V	240V	480/600V			
40 psi	250 psi	35-60 psi	H	2.0	3.0	5.0	5.0	115-150	69HA1	69HAU1
40 psi	250 psi	35-60 psi	H	2.0	5.0	5.0	5.0	115-150	69HB1	69HBU1
10 psi	125 psi	20-35 psi	I	2.0	3.0	5.0	5.0	100-125	69HA2	69HAU2
10 psi	125 psi	20-35 psi	I	2.0	5.0	5.0	5.0	100-125	69HB2	69HBU2
15 psi	60 psi	7-15 psi	J	2.0	3.0	5.0	5.0	30-40	69HA3	69HAU3
15 psi	60 psi	7-15 psi	J	2.0	5.0	5.0	5.0	30-40	69HB3	69HBU3

PSI Table E

Cut-In A	Cut-Out-B	
	Min.	Max.
20	40	60
30	50	70
40	60	80
50	70	90
60	80	100
70	90	100
80	100	100

PSI Table F

Cut-In A	Cut-Out-B	
	Min.	Max.
35	65	80
40	70	85
50	80	95
60	90	105
70	100	115
80	110	125
90	120	135
100	130	145
110	140	150
120	150	150

PSI Table G

Cut-In A	Cut-Out-B	
	Min.	Max.
45	75	100
55	85	110
65	95	120
75	105	130
85	115	140
95	130	150
105	140	160
115	150	170
125	160	175

PSI Table H

Cut-In A	Cut-Out-B	
	Min.	Max.
40	70	100
60	90	121
80	110	141
100	131	161
120	152	181
140	173	201
160	194	222
180	215	242
200	236	250
215	250	250

PSI Table I

Cut-In A	Cut-Out-B	
	Min.	Max.
8	28	46
10	30	48
20	40	58
30	50	68
40	60	78
50	70	88
60	80	98
70	90	109
80	99	119
90	109	125
100	119	125
107	125	125

PSI Table J

Cut-In A	Cut-Out-B	
	Min.	Max.
14	20	30
20	26	36
25	31	41
30	36	46
35	41	51
40	46	57
45	51	60
50	57	60
53	60	60

Electrical Ratings

Cat. No.	Control Circuit	Horsepower				DC 32V-230V
		1 Phase 112V	240V	3 Phase 240V	480-600V	
69MB	A600	1.5	2.0	3.0	–	1/4
69MC	A600	2.0	3.0	5.0	1	1/2
69HA	A600	2.0	3.0	5.0	5	2
69HB	A600	2.0	5.0	5.0	5	2

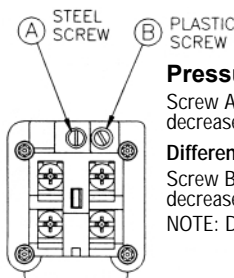

Pressure Adjustment Settings

Screw A—Turn clockwise to increase and counterclockwise to decrease pressure range (both cut-in and cut-out).

Differential Adjustment

Screw B—Turn clockwise to increase and counterclockwise to decrease cut-out pressure.

NOTE: Differentials shown on tables above are averages only.



Application

69M/69H Modifications

Description	Series	Catalog Number Suffix Add suffixes in order shown		
Auto-off disconnect lever	69M	L	No Min	
Unloader valve	69M	Y	NoMin	
Quick connects (load terminal only)	69M, 69H	A	24 Min	
Two grommets for 1/2" conduit hole	69M, 69H	G	24 Min	
NEMA 3 outdoor weatherproof enclosure— Cannot be used with Auto-Off disconnect lever		W	No Min	
NEMA 4 Cannot be used with Auto-Off disconnect lever		X	No Min	
Pipe Fittings				
1/4" male NPT	69M, 69H	2A	24 Min	
Four port manifold (each port is 1/4" NPT)	69M	2C	24 Min	
3/8" female NPT	69M	2J	24 Min	
1/4" female NPT	69H	2S	24 Min	
Special pressure settings: Suffix Z is followed by setting Example: 69MB7LYZ90120		Z†	24 Min	

† See Instruction Sheet included with switch for manual adjusting instructions.

69M Dimensions

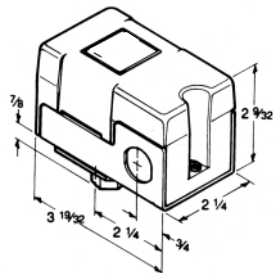

69M with Unloader Valve and/or Auto-Off Lever

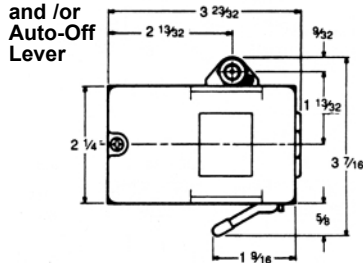

69M NEMA 3 & 4

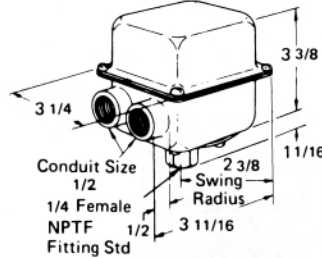

Connection Diagram

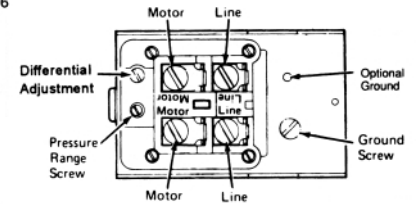

69H with Unloader Valve

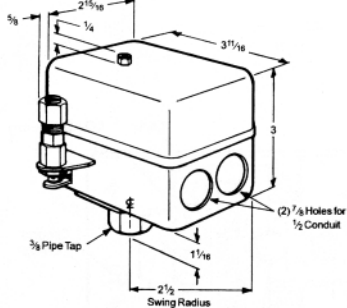

69M with 4 Port Manifold

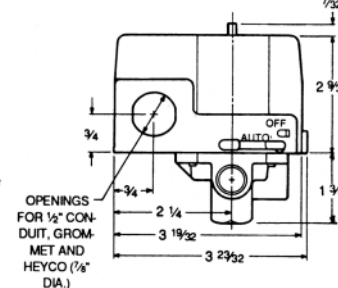

69HA3, 69HB3 NEMA 3 & 4

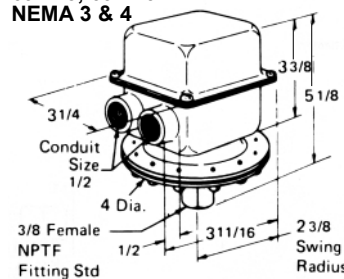

Replacement Parts

Description	Class	Cat No.	
Parts Kits (for 69HA1, 69HA2, 69HAU1, 69HAU2, 69HB1, 69HB2, 69HBU1, 69HBU2) Includes diaphragm and complete contact assembly	69H	75HB69	
Parts Kits (for 69HA3, 69HAU3, 69HB3, 69HBU3) Includes diaphragm and complete contact assembly	69H	75HB369	
Unloader valve	69M, 69H	69DCA	
Grommets for 1/2" conduit hole	69M, 69H	D00492001	

