

WORLDWIDE ELECTRIC CORPORATION
HdR SERIES PROGRAM - WORM GEAR SPEED REDUCERS
FLANGE INPUT - SHAFT OUTPUT - DIMENSIONS

MODEL # HdRF325-*-DE-145TC

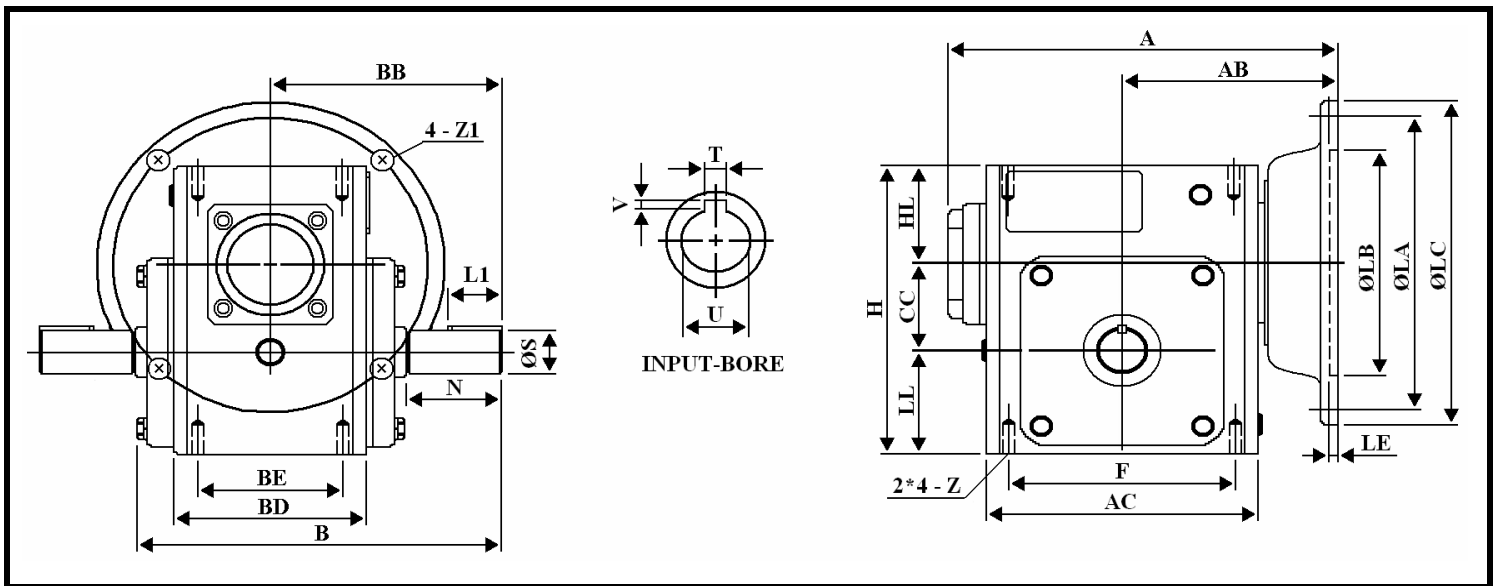
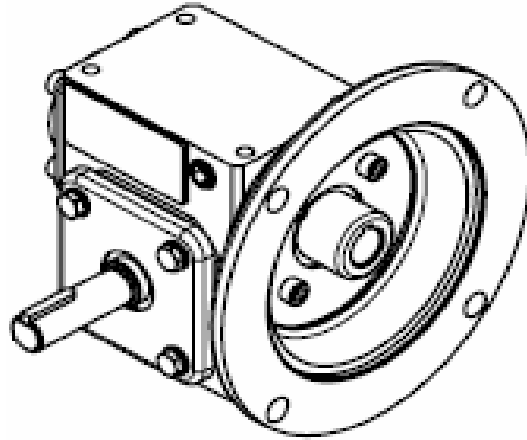

DOUBLE END OUTPUT - DIMENSIONS - Inches

Size	A	AB	AC	B	BB	BD	BE	CC	F	H	HL	LL	N	Z
325	11.42	6.063	9.016	11.014	7.059	5.748	4	3.25	7.5	9.375	2.625	3.5	3.25	7/16-14 UNC

Size	INPUT BORE		OUTPUT SHAFT			FLANGE					NEMA FRAME	OIL (OZ.)
	U	T*V	L1	S	W*Y	LA	LB	LC	LE	Z1		
325	0.875	3/16 * 3/32	2.438	1.375	5/16 * 5/32	5.875	4.5	6.496	0.157	0.433	145TC	73.75

* Suitable For Any Ratio

