

1 2 3 4 5 6 7 8 9

A

6.3 / ( 12.5 / )

B

C

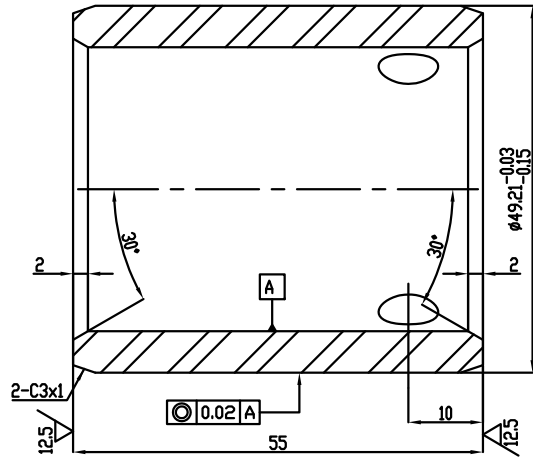

SECTION A-A

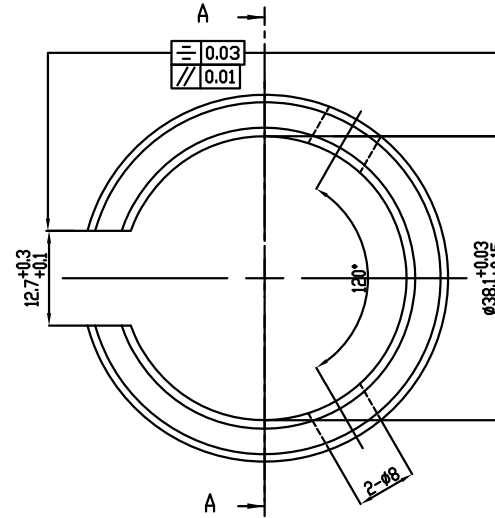

D

E

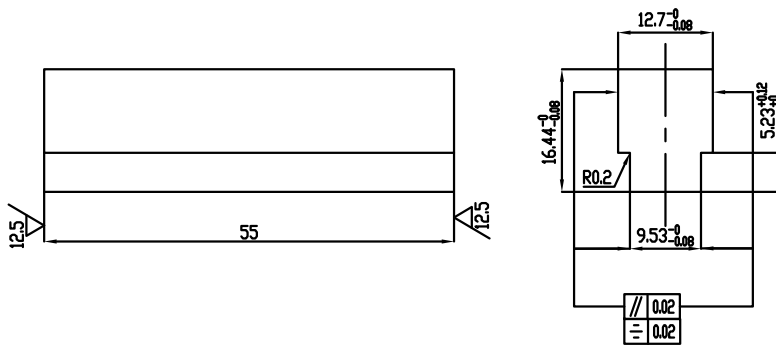

F

|           |      |                         |            |
|-----------|------|-------------------------|------------|
| WORLDWIDE |      |                         |            |
|           |      | TITLE : Bushing         |            |
| DWN.      | ALEX | DATE                    | 2022.02.10 |
|           |      | DWG. NO : HdrB11516.112 |            |
| DESN.     |      | PROJECTION              | 3RD. ANGLE |
| APPR.     |      | SCALE                   | 1:1        |
|           |      | E-mail:                 | REV: A     |