



WORLDWIDE ELECTRIC MOTOR DATA SHEET

OCCP30-18-286JM



HORSEPOWER	30		
RPM / POLES	1800 / 4		
VOLTAGE / PHASE	208 - 230 / 460 V / 3		
FRAME	286JM		
ENCLOSURE / DEGREE OF PROTECTION	ODP / IP23		
FREQUENCY	60 HZ Suitable For 50 HZ Operation With 1.0 SF		
FULL LOAD SPEED	1780 RPM		
SERVICE FACTOR	1.15 SF 60 HZ / 1.0 SF at 50 HZ		
INSULATION CLASS	F		
FULL LOAD AMPS; 230 / 460	71.8 / 35.9 A		
LOCKED ROTOR AMPS (STARTING); 230 / 460	499.6 / 249.8 A		
NO LOAD CURRENT	31.4 / 15.7 A		
NEMA CODE LETTER	H		
EFFICIENCY / POWER FACTOR	<u>LOAD</u>	<u>EFF.</u>	<u>P.F.</u>
	100%	94.1%	0.82
	75%	94.0%	0.77
	50%	93.3%	0.66
DUTY CYCLE	S1 / Continuous		
TORQUE	<u>FULL LOAD</u>	<u>LRT</u>	<u>BDT</u>
	3.03 lb.ft.	278.0%	319.0%
SLIP	1.09%		
NEMA DESIGN	B		
NUMBER OF STARTS (Hot / Cold)	2 Hot / 3 Cold		
MAX. AMBIENT TEMPERATURE	40° C		
MAX. ELEVATION	3300 Ft. Above Sea Level		
TEMPERATURE RISE (At Full Load)	80° C		
DE BEARING	6311Z		
ODE BEARING	6310Z		
GREASE TYPE	Multemp SRL		
MOUNTING	F1		
ROTATION	Bi-Directional		
APPROXIMATE WEIGHT	335 Lbs.		
AREA CLASSIFICATION	Non-Hazardous		
INVERTER RATING	10:1 CT / 20:1 VT PWM Type		
SPECIFICATION - In Accordance With	NEMA, UR		



JULY 16, 2020

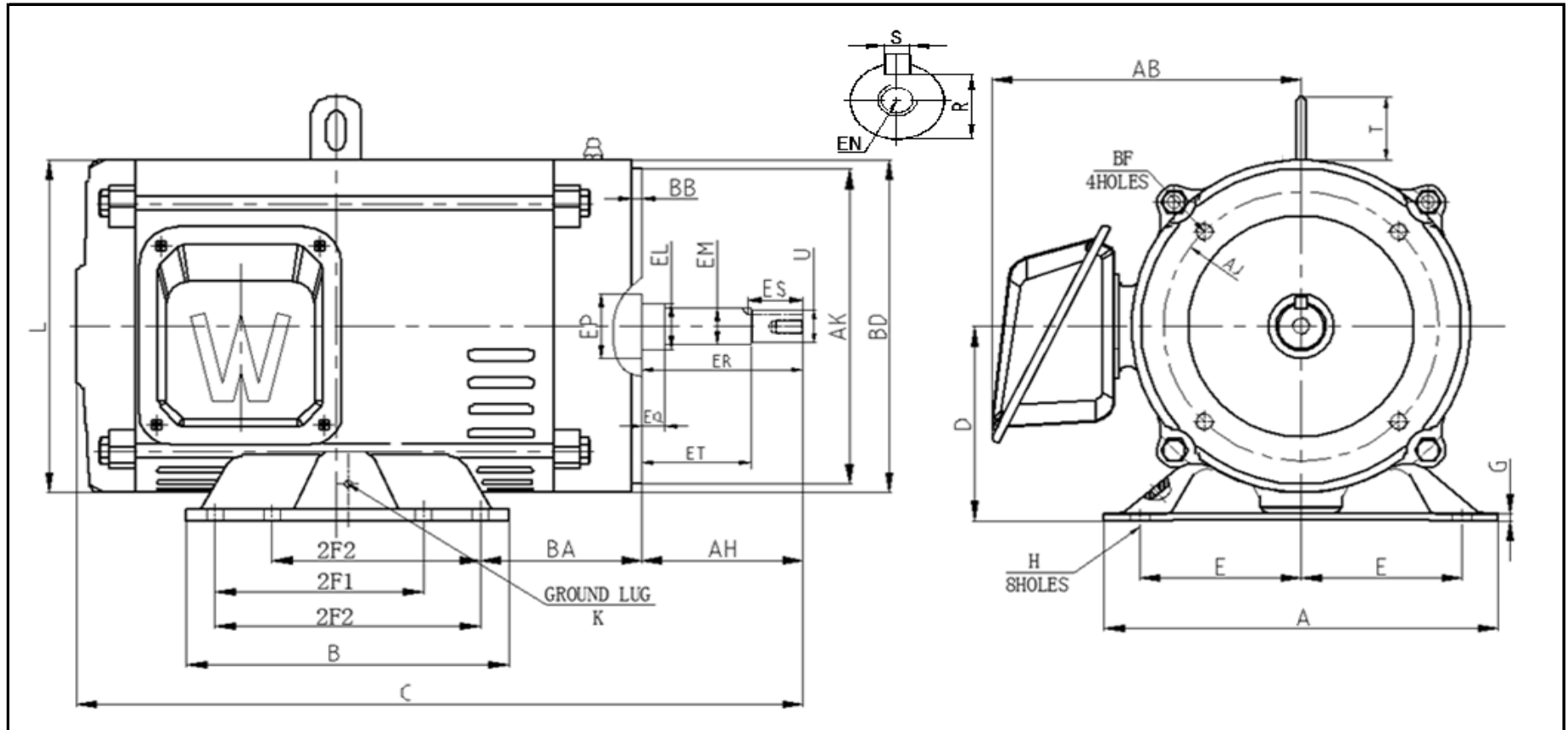

DIMENSIONS - INCHES

MOUNTING					A	B	C	D	G	AB	L	T	KEYSET	KEY	
E	2F1	2F2	H	BA									R	ES	S
5.5	9.5	11	0.53	4.75	12.8	12.8	25.6	7	0.24	11.1	12.2	2.48	1.1	2.53	0.25

FLANGE					AH	SHAFT EXTENSION								K
AK	AJ	BF	BB	BD		EL	EM	EP	EQ	ER	ET	EN	U	
12.5	11	5/8-11 * 0.94	0.28	14	5.25	1.75	1.375	2.13	0.625	5.25	3	1/2-13 * 1.0	1.25	M6