

WORLDWIDE ELECTRIC MOTOR DRAWING

OCCP-326JP

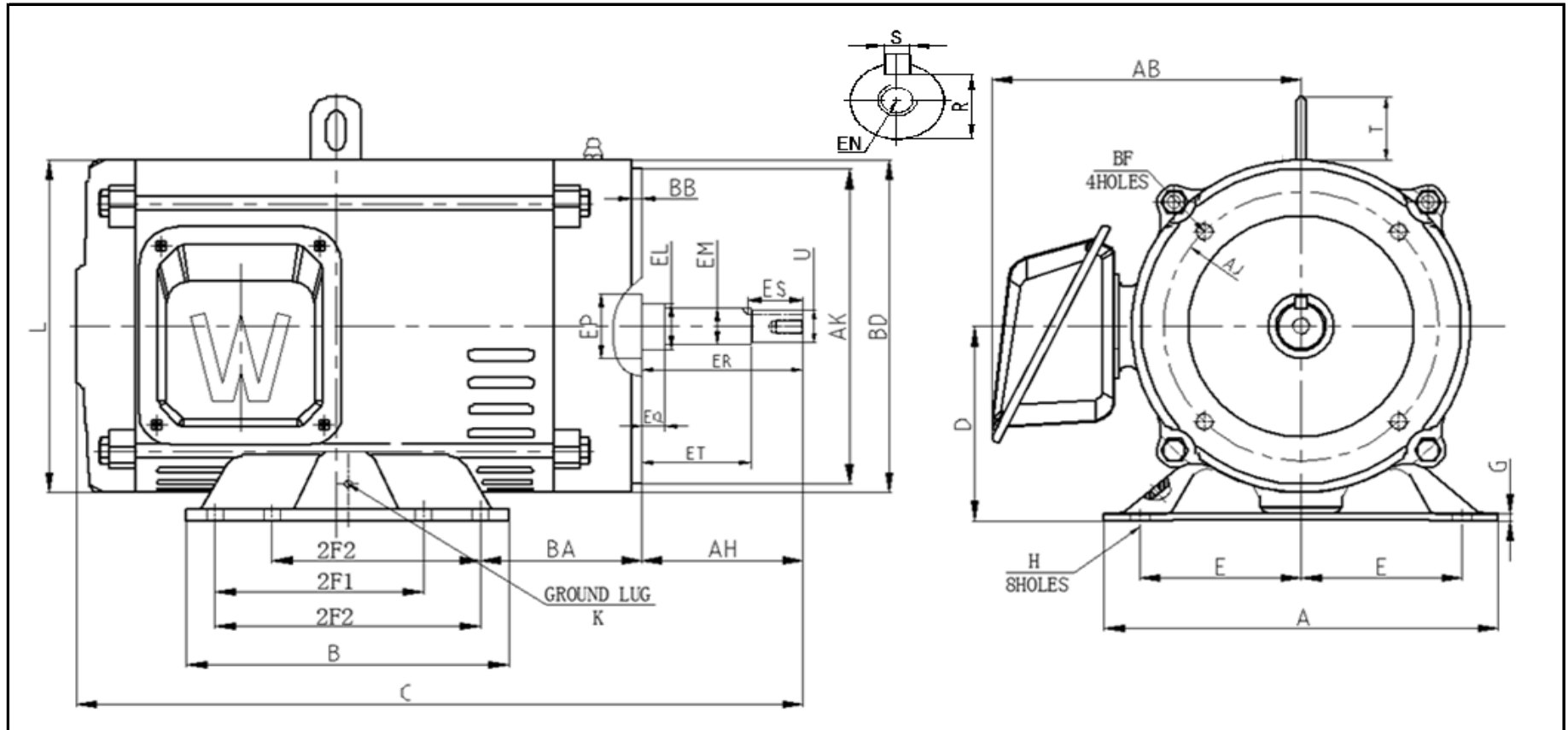

DIMENSIONS - INCHES

MOUNTING					A	B	C	D	G	AB	L	T	KEYSET		KEY	
E	2F1	2F2	H	BA									R	ES	S	
6.25	10.5	12	0.66	5.25	15.08	14	30.5	8	0.275	13.1	13.97	2.48	1.1	2.53	0.25	

FLANGE					AH	SHAFT EXTENSION								K
AK	AJ	BF	BB	BD		EL	EM	EP	EQ	ER	ET	EN	U	
12.5	11	5/8-11 * 0.94	0.28	14	8.125	1.75	1.375	2.13	2.375	8.13	5.875	1/2-13 * 1.0	1.25	M8