

WORLDWIDE ELECTRIC MOTOR DRAWING

OCCP-182JP

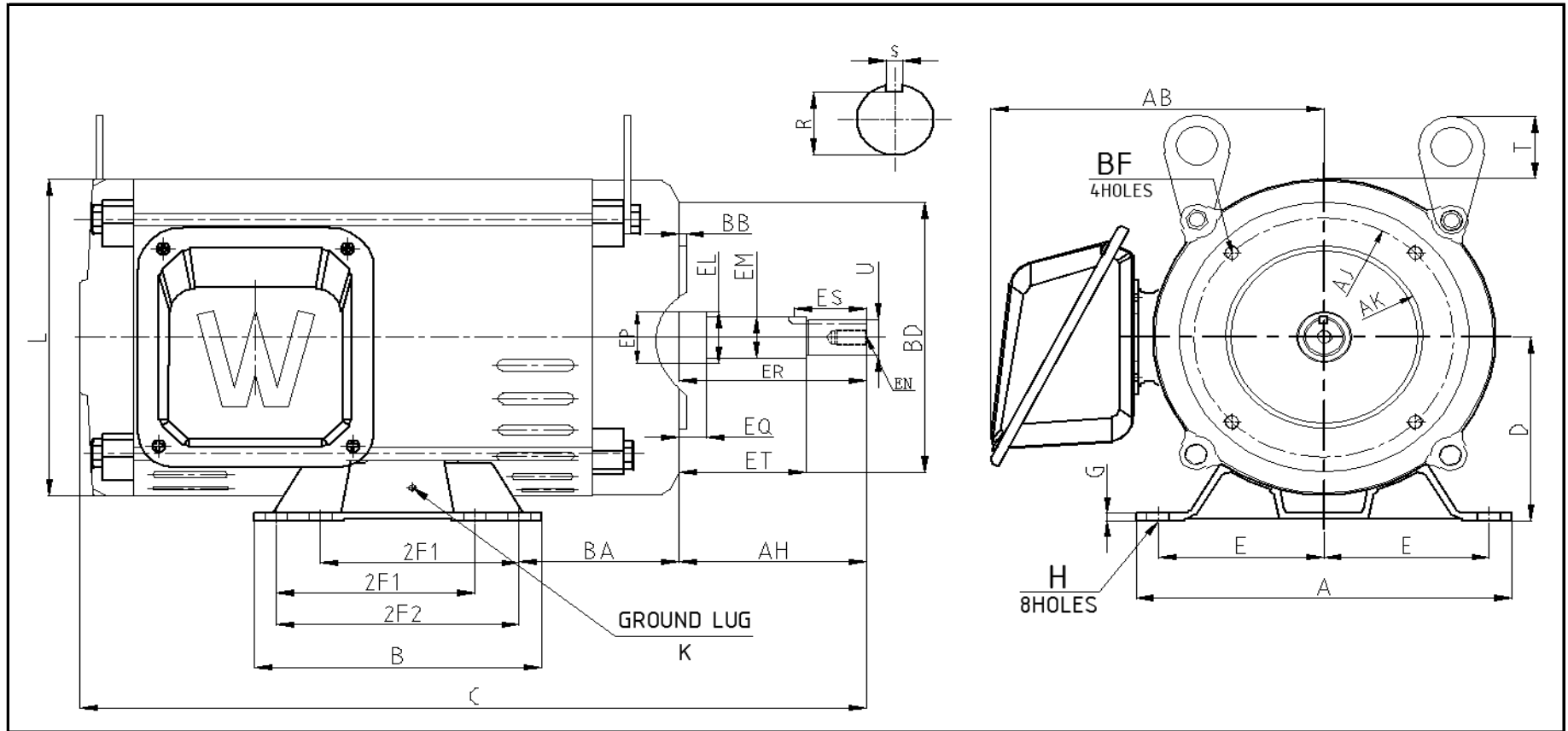

DIMENSIONS - INCHES

MOUNTING					A	B	C	D	G	AB	L	T	KEYSET	KEY	
E	2F1	2F2	H	BA									R	ES	S
3.75	5.5	4.5	0.41	3.63	8.5	6.5	20.873	4.5	0.41	6.5	7.8	1.53	0.771	1.65	0.188

FLANGE				AH	SHAFT EXTENSION								K	
AK	AJ	BF	BB		BD	EL	EM	EP	EQ	ER	ET	EN		U
4.5	5.875	3/8-16 * 0.75	0.156	6.63	7.313	1.25	1	1.25	1.563	7.31	5.938	3/8-16 * 0.75	.875	M5

REVISED - 02/10/18