

**WORLDWIDE ELECTRIC CORPORATION**  
**HdR SERIES PROGRAM - WORM GEAR SPEED REDUCERS**  
**FLANGE INPUT - SHAFT OUTPUT - DIMENSIONS**

**MODEL # HdRF325-\*-DE-184TC**

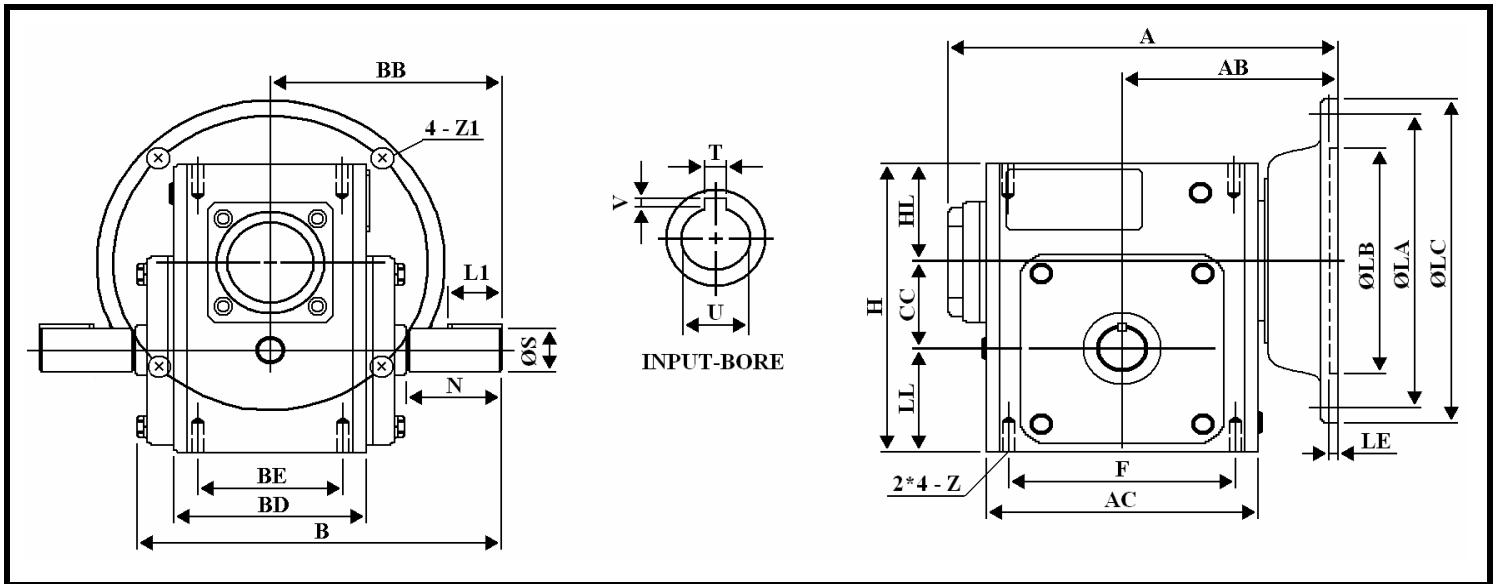
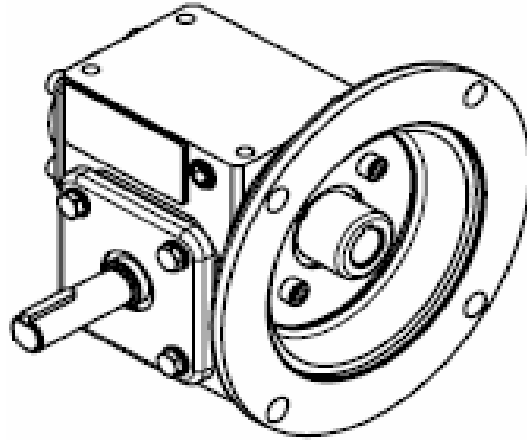

**DOUBLE END OUTPUT - DIMENSIONS - Inches**

Size	A	AB	AC	B	BB	BD	BE	CC	F	H	HL	LL	N	Z
325	12.59	7.244	9.016	11.014	7.059	5.748	4	3.25	7.5	9.375	2.625	3.5	3.25	7/16-14 UNC

Size	INPUT BORE		OUTPUT SHAFT			FLANGE					NEMA FRAME	OIL (OZ.)
	U	T*V	L1	S	W*Y	LA	LB	LC	LE	Z1		
325	1.125	1/4 * 1/8	2.438	1.375	5/16 * 5/32	7.25	8.5	9	0.197	0.551	184TC	73.75

\* Suitable For Any Ratio

