



WORLDWIDE ELECTRIC MOTOR DATA SHEET

IXPEWWE3-12-213T



| | | | |
|----------------------------------|--|-------------|-------------|
| HORSEPOWER | 3 | | |
| RPM / POLES | 1200 / 6 | | |
| VOLTAGE / PHASE | 230 / 460 V / 3 | | |
| FRAME | 213T | | |
| ENCLOSURE / DEGREE OF PROTECTION | TEFC / IP55 | | |
| FREQUENCY | 60 HZ Suitable For 50 HZ Operation With 1.0 SF | | |
| FULL LOAD SPEED | 1182 RPM | | |
| SERVICE FACTOR | 1.15 SF | | |
| INSULATION CLASS | F | | |
| FULL LOAD AMPS | 7.9 / 3.95 A | | |
| LOCKED ROTOR AMPS (STARTING) | 64.0 / 32.0 A | | |
| NO LOAD CURRENT | | | |
| NEMA CODE LETTER | K | | |
| EFFICIENCY / POWER FACTOR | <u>LOAD</u> | <u>EFF.</u> | <u>P.F.</u> |
| | 100% | 89.5% | 0.71 |
| | 75% | 89.0% | 0.65 |
| | 50% | 87.5% | 0.53 |
| DUTY CYCLE | S1 / Continuous | | |
| TORQUE | <u>FULL LOAD</u> | <u>LRT</u> | <u>BDT</u> |
| | 13.3 lb.ft. | 155% | 230% |
| SLIP | 1.50% | | |
| NEMA DESIGN | B | | |
| MOMENT OF INERTIA | | | |
| NUMBER OF STARTS (Hot / Cold) | 1 Hot / 2 Cold (Per Hour) | | |
| MAX. AMBIENT TEMPERATURE | 40° C | | |
| MAX. ELEVATION | 3300 Ft. Above Sea Level | | |
| TEMPERATURE RISE (At Full Load) | 80° C | | |
| DE BEARING | 6308-ZZ | | |
| ODE BEARING | 6308-ZZ | | |
| GREASE TYPE | Mobil Polyrex EM | | |
| MOUNTING | F1 | | |
| ROTATION | Bi-Directional | | |
| APPROXIMATE WEIGHT | 238 lbs. | | |
| TEMPERATURE CODE AT 40°C AMBIENT | T3C | | |
| TEMPERATURE CODE AT 55°C AMBIENT | T3C | | |
| AREA CLASSIFICATION | Class I, Division I, Groups C & D | | |
| | Class II, Division I, Groups F & G | | |
| INVERTER RATING | 5:1 CT / 10:1 VT PWM Type | | |





WORLDWIDE ELECTRIC MOTOR DRAWING

IXPEWWE-213T

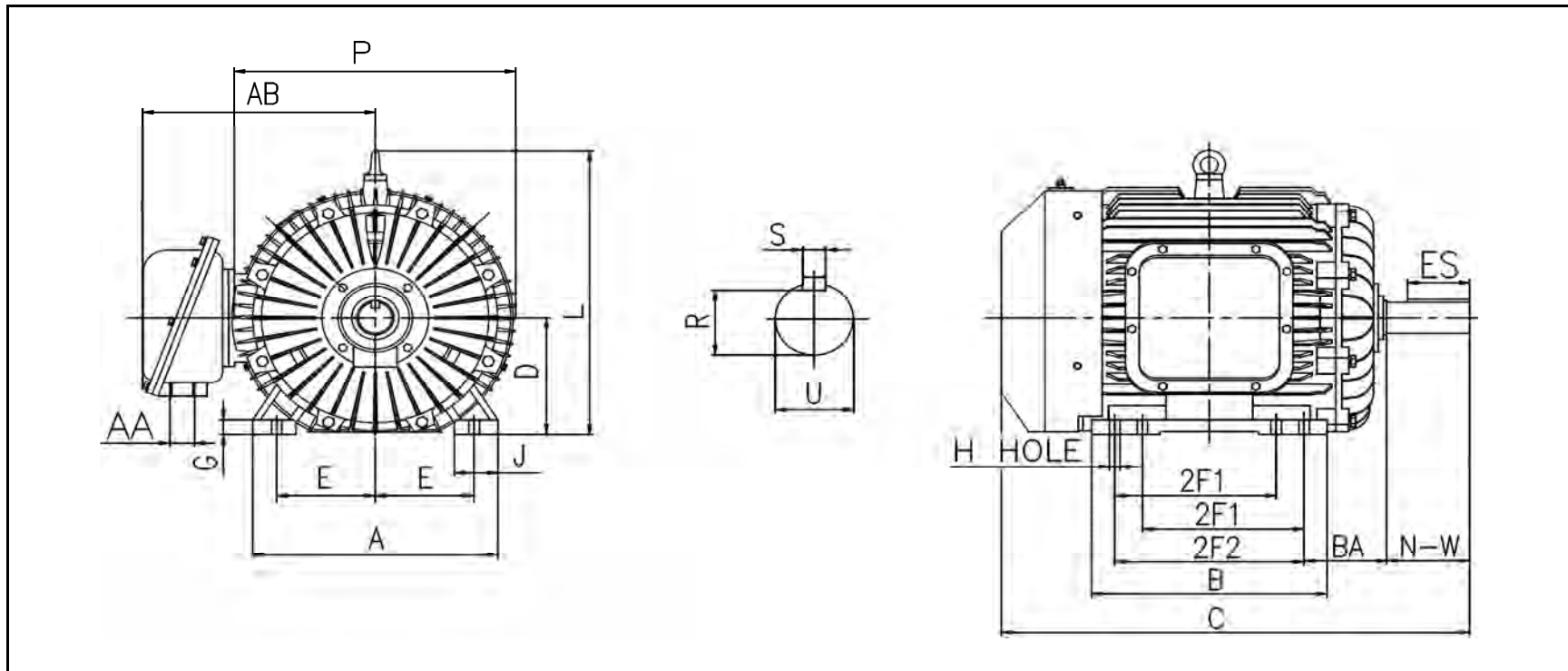

| MOUNTING | | | | | A | B | C | D | G | J |
|----------|-----|-----|------|-----|------|-----|-------|------|------|-----|
| E | 2F1 | 2F2 | H | BA | | | | | | |
| 4.25 | 5.5 | 7 | 0.41 | 3.5 | 10.4 | 9.3 | 21.85 | 5.25 | 0.83 | 2.4 |

| L | P | AA | AB | KEY | KEYSEAT | SHAFT | N-W | U |
|----|------|----|------|------|---------|-------|------|-------|
| | | | | ES | S | R | | |
| 13 | 12.2 | 1 | 11.4 | 2.44 | 0.312 | 1.201 | 3.38 | 1.375 |

ALL DIMENSIONS IN INCHES

REVISED - 09/16/16