



WORLDWIDE ELECTRIC MOTOR DATA SHEET

IXPEWWE40-12-364T



HORSEPOWER	40		
RPM / POLES	1200 / 6		
VOLTAGE / PHASE	230 / 460 V / 3		
FRAME	364T		
ENCLOSURE / DEGREE OF PROTECTION	TEFC / IP55		
FREQUENCY	60 HZ Suitable For 50 HZ Operation With 1.0 SF		
FULL LOAD SPEED	1188 RPM		
SERVICE FACTOR	1.15 SF		
INSULATION CLASS	F		
FULL LOAD AMPS	92.0 / 46.0 A		
LOCKED ROTOR AMPS (STARTING)	580 / 290 A		
NO LOAD CURRENT			
NEMA CODE LETTER	G		
EFFICIENCY / POWER FACTOR	<u>LOAD</u>	<u>EFF.</u>	<u>P.F.</u>
	100%	94.1%	0.83
	75%	94.3%	0.84
	50%	93.9%	0.78
DUTY CYCLE	S1 / Continuous		
TORQUE	<u>FULL LOAD</u>	<u>LRT</u>	<u>BDT</u>
	176.8 lb.ft.	135%	200%
SLIP	1.00%		
NEMA DESIGN	B		
MOMENT OF INERTIA			
NUMBER OF STARTS (Hot / Cold)	1 Hot / 2 Cold (Per Hour)		
MAX. AMBIENT TEMPERATURE	40° C		
MAX. ELEVATION	3300 Ft. Above Sea Level		
TEMPERATURE RISE (At Full Load)	80° C		
DE BEARING	6314		
ODE BEARING	6314		
GREASE TYPE	Mobil Polyrex EM		
MOUNTING	F1		
ROTATION	Bi-Directional		
APPROXIMATE WEIGHT	911 lbs.		
TEMPERATURE CODE AT 40°C AMBIENT	T3C		
TEMPERATURE CODE AT 55°C AMBIENT	T2C		
AREA CLASSIFICATION	Class I, Division I, Groups C & D		
	Class II, Division I, Groups F & G		
INVERTER RATING	5:1 CT / 10:1 VT PWM Type		





WORLDWIDE ELECTRIC MOTOR DRAWING

IXPEWWE-364T

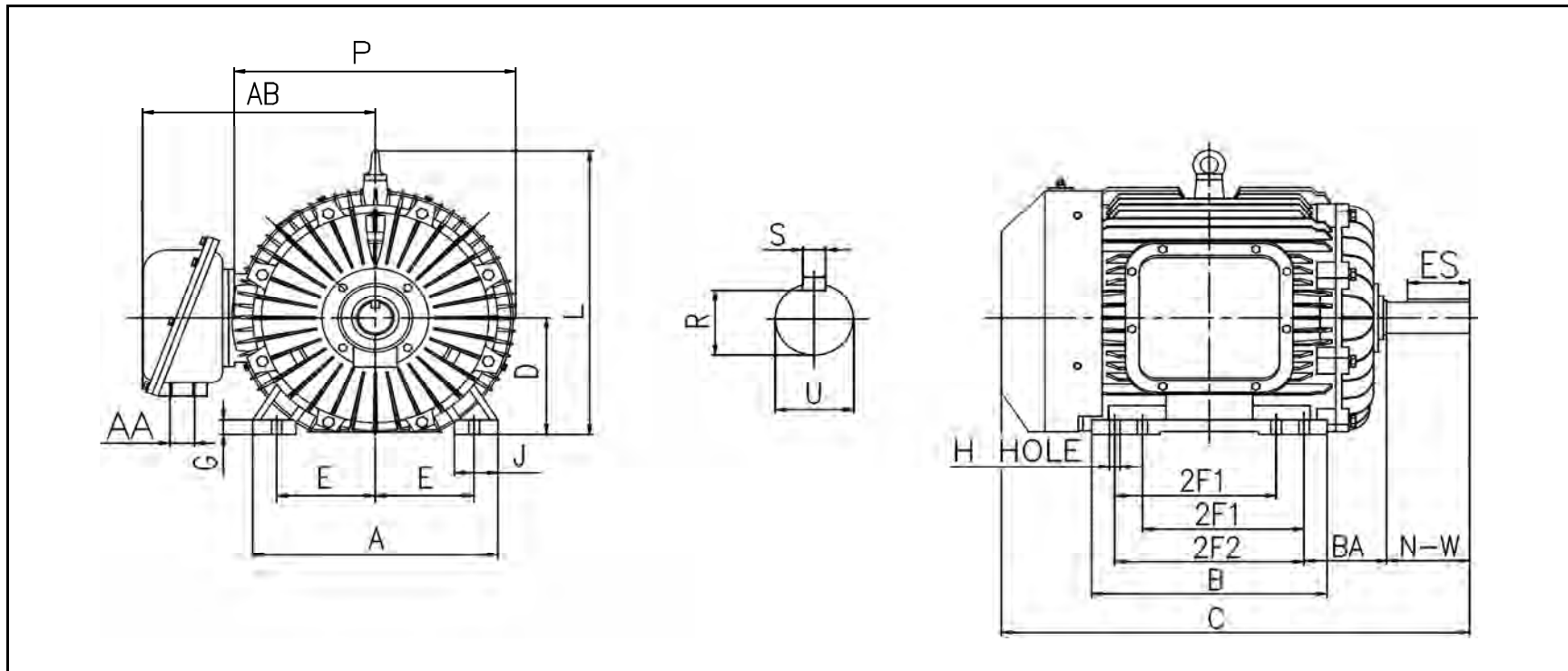

MOUNTING					A	B	C	D	G	J
E	2F1	2F2	H	BA	17.1	15.5	34.84	9	0.98	2.95
7	11.25	12.25	0.66	5.88						

L	P	AA	AB	KEY	KEYSEAT	SHAFT	N-W	U
22	19.7	3	17.1	ES	S	R	5.88	2.375
				4.29	0.625	2.021		

ALL DIMENSIONS IN INCHES

REVISED - 09/16/16