

DATA SHEET

Premium Efficiency Motor: **LAM10-18-215TC**

60 Hz

WorldWide Electric Corporation

1 (800) 808-2131

Worldwideelectric.net



Document Generated: 14-Sep-2023
Document ID:

Customer:

MOTOR INFORMATION	
HP	10
RPM	1800
Phase	3
Frequency	60 Hz
Voltage	230/460
Frame Size	213/5TC
Enclosure	TEFC
Degree of Protection	IP55
Service Factor	1.25
Poles	4
Full Load Speed	1750
Insulation Class	F
Temp Rise	80°C
NEMA Code Letter	H
Duty Cycle	S1 / Continuous
Slip	2.78%
NEMA Design	B
Moment of Inertia	0.906 lb.ft.^2
Locked Rotor Time (Hot)	12 seconds
Sound Pressure Level	79 dB(A)
Number of Starts	2 Cold/1 Hot
Max Ambient Temperature	40°C
Max Elevation	1000 m.a.s.l (3300 f.a.s.l)
Mounting	F1
Rotation	Bi-Directional
Area of Classification	Class 1 Division 2 Groups A,B,C,D T3B
Inverter Rating	10:1 CT / 20:1 VT
Standard	NEMA MG-1
Approvals	UL, CE, IEEE45, ABS

EFFICIENCY/POWER FACTOR		
LOAD	EFF	P. F.
100%	91.7 %	0.88
75%	92.7 %	0.85
50%	92.6 %	0.77

TORQUE		
FULL LOAD	LRT	BDT
30.06 lb.ft.	320 %	396 %

AMPERAGE INFORMATION		
	230V	460V
Full Load Amps	23.2A	11.6
Locked Rotor Amps	173.2A	86.6A
No Load Current	7.4A	3.7A
Usable at 208V	25.7 A	

BEARING INFORMATION	
DE Bearing	6308 ZZ
ODE Bearing	6306 ZZ
Grease Type	NSK SN7
DE Regreasing Interval	-- Hours
ODE Regreasing Interval	-- Hours
Grease Quantity	--

ADDITIONAL DATA	
F2 Suitable	Yes
Shaft Material	AISI 1045
Connection Diagram	9 Lead Wye
Approximate Weight	196.2 lbs.

MOTOR DRAWING

Premium Efficiency Motor: **LAM10-18-215TC**

WorldWide Electric Corporation

1 (800) 808-2131

Worldwideelectric.net

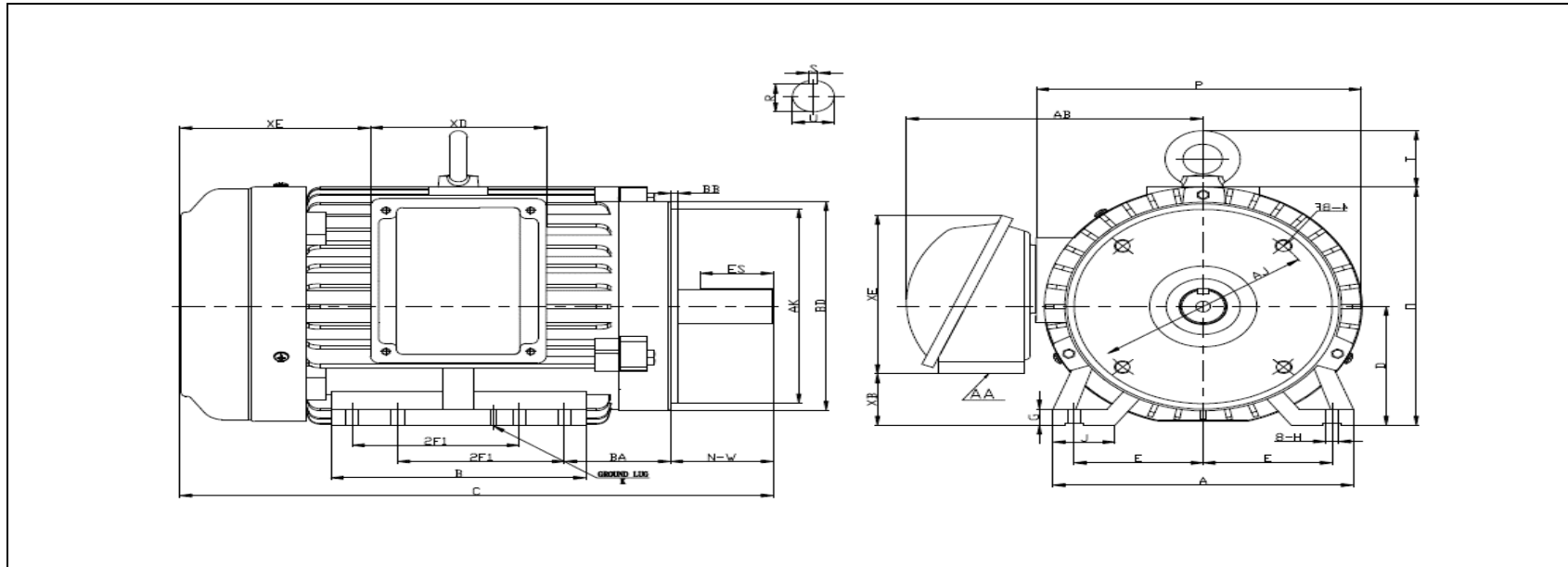

DIMENSION - INCHES

MOUNTING					A	B	C	D	G	P	O	T	AB
E	2F1	2F2	H	BA									
4.25	5.5	7	0.43	3.5	9.88	8.405	19.5	5.25	0.708	10.8	10.53	1.72	9.8

SHAFT & KEY				
S	ES	R	N-W	U
0.31	2.41	1.201	3.38	1.375

TERMINAL BOX				
AA	XB	XC	XD	XE
1 NPT	1.63	7.9	5.8	6.5

GROUND LUG
M5

FLANGE				
AK	BD	AJ	BF	BB
8.5	9	7.25	4*1/2-13	0.25

PERFORMANCE CURVES

Premium Efficiency Motor:

LAM10-18-215TC

WorldWide Electric Corporation

1 (800) 808-2131

Worldwideelectric.net



Document Generated: 14-Sep-2023
Document ID:

Customer:

Motor Type	LAM		FL Speed	1750	
Output Rating (HP)	10		LRT (%FLT)	320	
Full Load Torque	30.06	lb.ft	460 volt FLA	11.6	
Rotor Wk ²	0.906	lb-ft ²	230 volt FLA	23.2A	
			BDT (%FLT)	396	

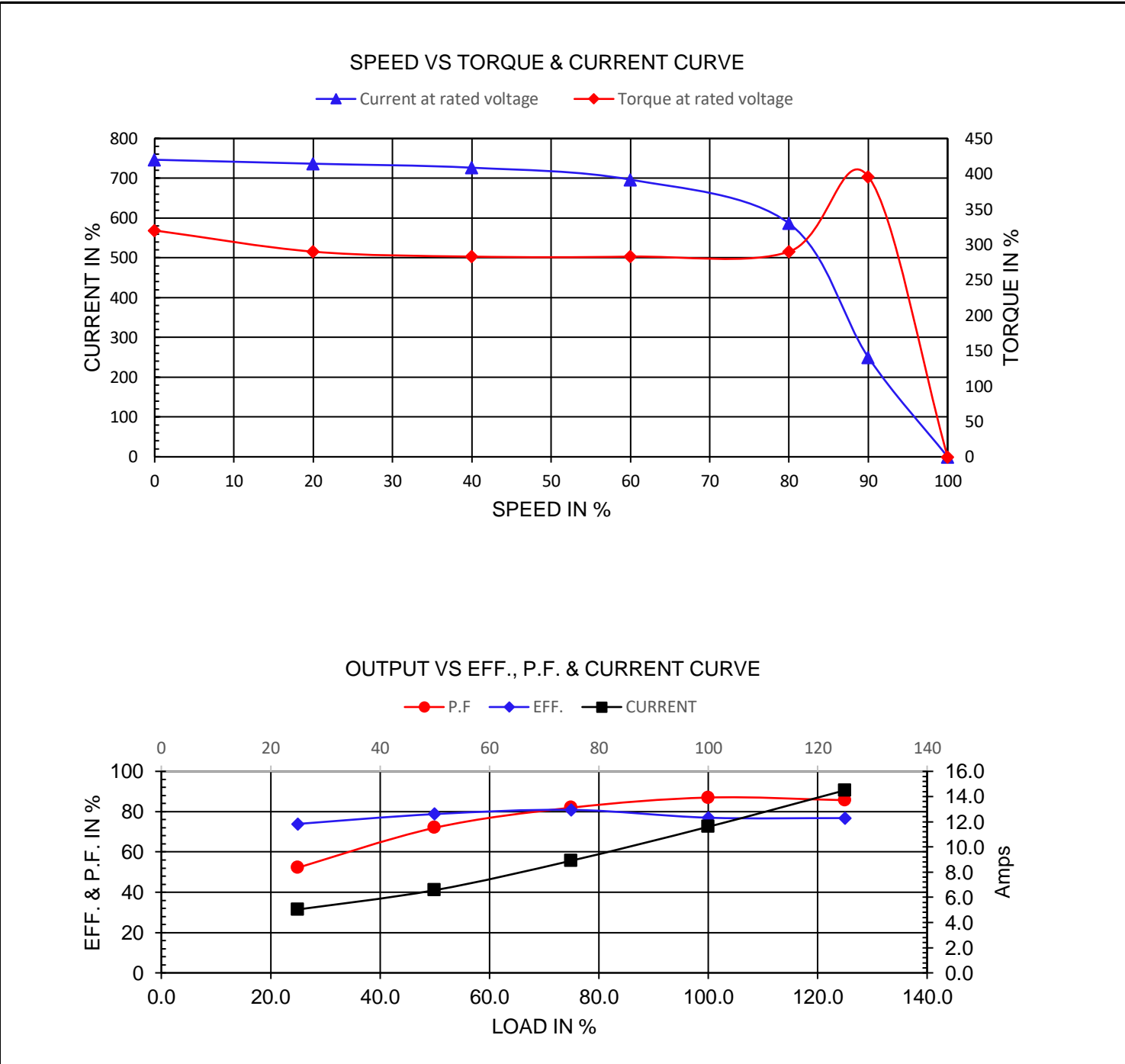

NAMEPLATE / WIRING

Premium Efficiency Motor: **LAM10-18-215TC**

WorldWide Electric Corporation

1 (800) 808-2131

Worldwideelectric.net



Document Generated: 14-Sep-2023
Document ID:

Customer:

SAMPLE NAMEPLATE DATA

		THREE PHASE SEVERE DUTY MOTOR IEE45																																						
Model :		Encl :	Type :	SN :			<table border="1"> <tr> <td>4</td> <td>5</td> <td>6</td> </tr> <tr> <td>7</td> <td>8</td> <td>9</td> </tr> <tr> <td>1</td> <td>2</td> <td>3</td> </tr> <tr> <td>L1</td> <td>L2</td> <td>L3</td> </tr> <tr> <td colspan="3" style="text-align: center;">230 V</td> </tr> <tr> <td>7</td> <td>8</td> <td>9</td> </tr> <tr> <td>4</td> <td>5</td> <td>6</td> </tr> <tr> <td>1</td> <td>2</td> <td>3</td> </tr> <tr> <td>L1</td> <td>L2</td> <td>L3</td> </tr> <tr> <td colspan="3" style="text-align: center;">460 V</td> </tr> </table>				4	5	6	7	8	9	1	2	3	L1	L2	L3	230 V			7	8	9	4	5	6	1	2	3	L1	L2	L3	460 V		
4	5	6																																						
7	8	9																																						
1	2	3																																						
L1	L2	L3																																						
230 V																																								
7	8	9																																						
4	5	6																																						
1	2	3																																						
L1	L2	L3																																						
460 V																																								
HP :	Poles :	FR :	Ins :	Duty: Cont	IP :	Max Amb 40°C																																		
Hz :		CODE :	Hz :		Design :																																			
Volts :		P.F :	Volts :		DE BRG :																																			
Amps :		Eff :	Amps :		ODE BRG :																																			
RPM :		S.F :	RPM :		WT :																																			
			S.F :		Date :																																			
CC306B					LOUIS ALLIS		196			UL certified Class I, Division II, Groups A,B,C,D T3B																														

Model:	LAM10-18-215TC	Encl:	TEFC	Type:	AEH3	
HP:	10	Poles	4	FR:	213/5TC	Ins: F
Hz:	60	CODE:	H	Hz	50	HP: 10
Volts:	230/460	P.F:	0.88	Volts:	190/380	Design: B
Amps:	23.2/11.6	Eff:	0.917	Amps	27.8/13.9	DE BRG: 6308 ZZ
RPM:	1750	S.F:	1.25	RPM	1450	ODE BRG: 6306 ZZ
				S.F:	1.00	WT: 196.2 lbs.