

DATA SHEET

Premium Efficiency Motor: **LAM2-18-145T**

60 Hz

WorldWide Electric Corporation

1 (800) 808-2131

Worldwideelectric.net



Document Generated: 8-Sep-2023
Document ID:

Customer:

MOTOR INFORMATION	
HP	2
RPM	1800
Phase	3
Frequency	60 Hz
Voltage	230/460
Frame Size	143/5T
Enclosure	TEFC
Degree of Protection	IP55
Service Factor	1.25
Poles	4
Full Load Speed	1730
Insulation Class	F
Temp Rise	80°C
NEMA Code Letter	L
Duty Cycle	S1 / Continuous
Slip	3.89%
NEMA Design	B
Moment of Inertia	0.101122630331754 lb.ft.^2
Locked Rotor Time (Hot)	12 seconds
Sound Pressure Level	70 dB(A)
Number of Starts	2 Cold/1 Hot
Max Ambient Temperature	40°C
Max Elevation	1000 m.a.s.l (3300 f.a.s.l)
Mounting	Rigid
Rotation	Bi-Directional
Area of Classification	Class 1 Division 2 Groups A,B,C,D T3B
Inverter Rating	10:1 CT / 20:1 VT
Standard	NEMA MG-1
Approvals	UL, CE, IEEE45, ABS

EFFICIENCY/POWER FACTOR		
LOAD	EFF	P. F.
100%	86.5 %	0.8
75%	87.5 %	0.73
50%	86.4 %	0.6

TORQUE		
FULL LOAD	LRT	BDT
6 lb.ft.	395 %	471 %

AMPERAGE INFORMATION		
	230V	460V
Full Load Amps	5.4A	2.7A
Locked Rotor Amps	45.6A	22.8A
No Load Current	2.8A	1.4A
Usable at 208V		6 A

BEARING INFORMATION	
DE Bearing	6205 ZZ
ODE Bearing	6204 ZZ
Grease Type	NSK SN7
DE Regreasing Interval	-- Hours
ODE Regreasing Interval	-- Hours
Grease Quantity	--

ADDITIONAL DATA	
F2 Suitable	Yes
Shaft Material	AISI 1045
Connection Diagram	9 Lead Wye
Approximate Weight	58.4 lbs.

MOTOR DRAWING

Premium Efficiency Motor: **LAM2-18-145T**

WorldWide Electric Corporation

1 (800) 808-2131

Worldwideelectric.net

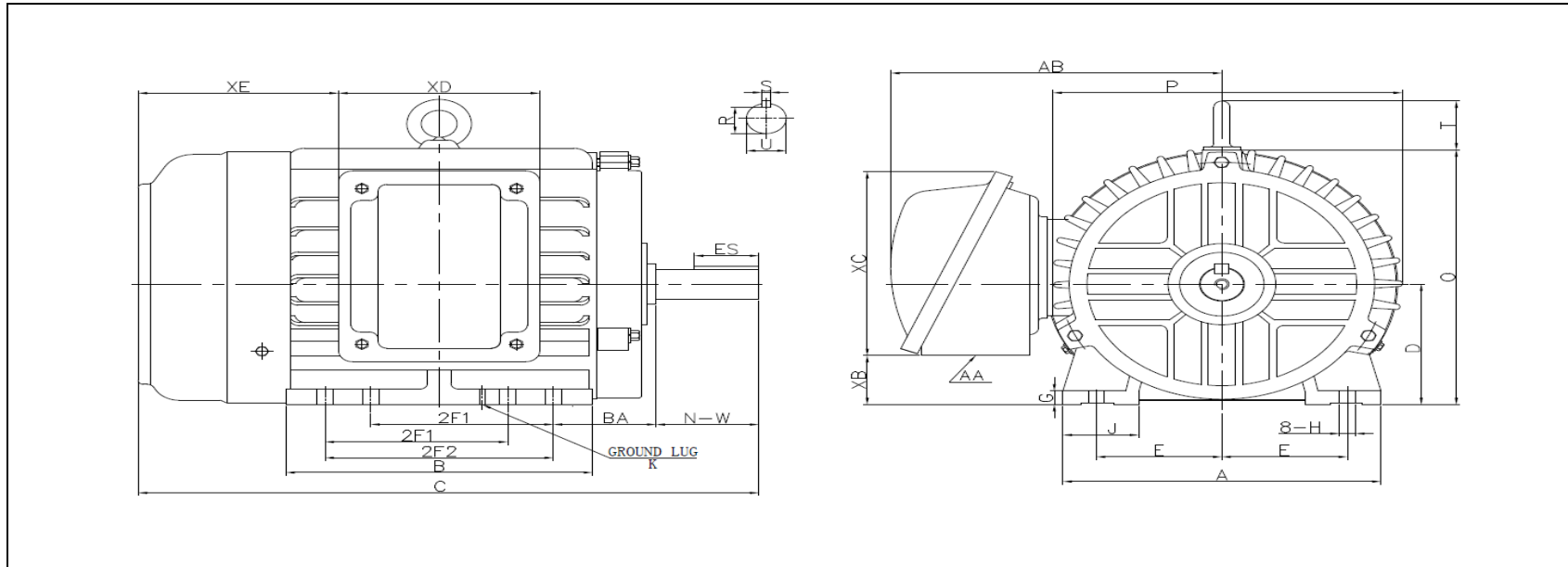

DIMENSION - INCHES

MOUNTING					A	B	C	D	G	J	P	O	T	AB
E	2F1	2F2	H	BA										
2.75	4	5	0.34	2.25	7	6.77	13.59	3.5	0.39	1.66	7.66	7.41	1.4	7.3

SHAFT & KEY				
S	ES	R	N-W	U
0.188	1.41	0.771	2.25	0.875

TERMINAL BOX				
AA	XB	XC	XD	XE
3/4 NPT	1.42	5.4	4.4	4.4

GROUND LUG
M5

PERFORMANCE CURVES

WorldWide Electric Corporation

1 (800) 808-2131

Worldwideelectric.net



Premium Efficiency Motor:

LAM2-18-145T

Document Generated: 8-Sep-2023
Document ID:

Customer:

Motor Type	AEH3		FL Speed	1730	
Output Rating (HP)	2		LRT (%FLT)	395	
Full Load Torque	6	lb.ft	460 volt FLA	2.7	
Rotor Wk^2	0.101123	lb-ft^2	230 volt FLA	5.4	
			BDT (%FLT)	471	

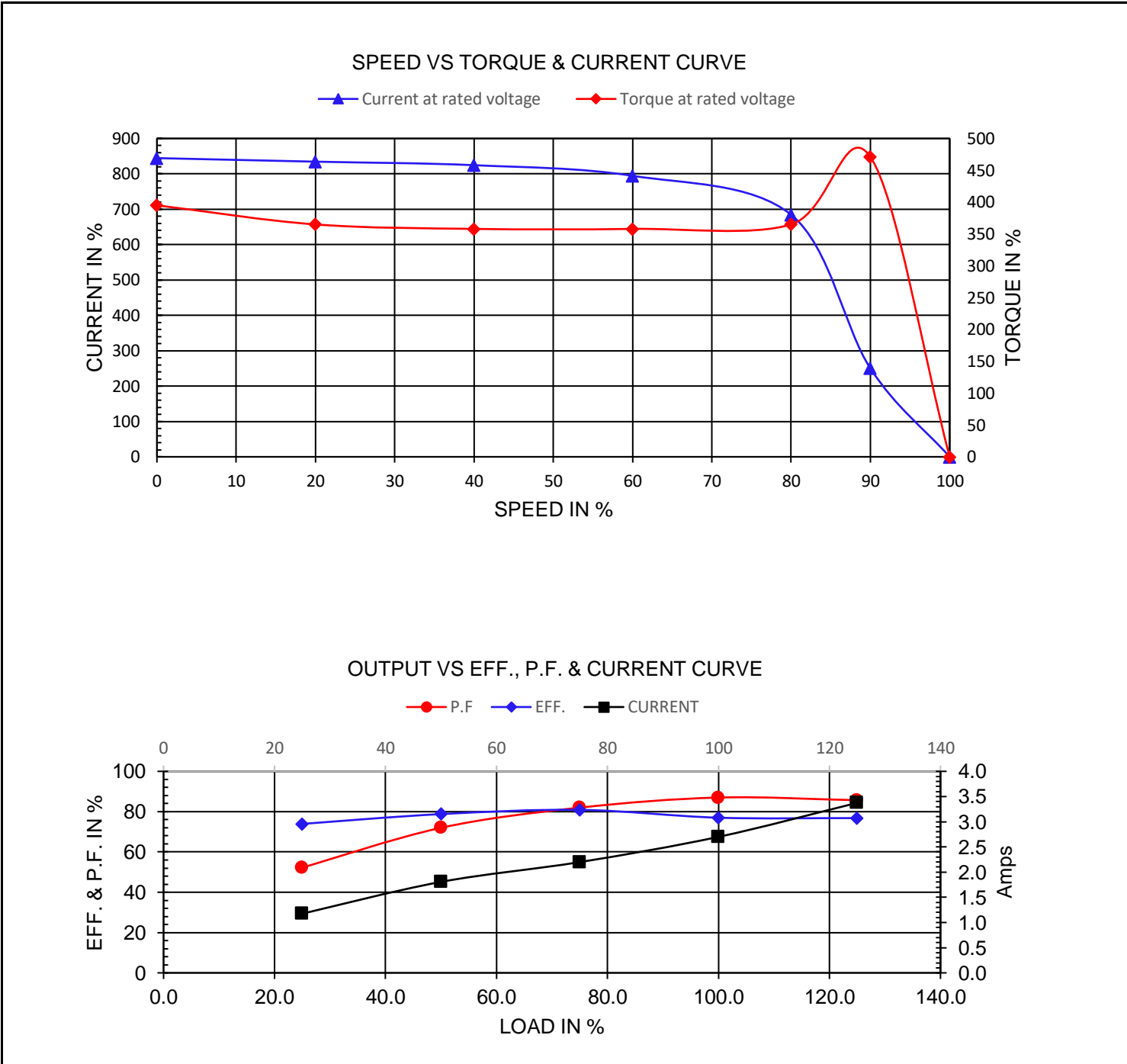

NAMEPLATE / WIRING

Premium Efficiency Motor: **LAM2-18-145T**

WorldWide Electric Corporation

1 (800) 808-2131

Worldwideelectric.net



Document Generated: 8-Sep-2023
Document ID:

Customer:

SAMPLE NAMEPLATE DATA

		THREE PHASE SEVERE DUTY MOTOR I EEE45					
Model :		Encl :	Type :		SN :		
HP :	Poles :	FR :	Ins :	Duty: Cont	IP :	Max Amb 40°C	
Hz :	CODE :	Hz :	Design :				UL certified Class I, Division II, Groups A,B,C,D T3B
Volts :	P.F. :	Volts :	DE BRG :				
Amps :	Eff :	Amps :	ODE BRG :				
RPM :	S.F. :	RPM :	WT :				
				S.F. :	Date :		
CC306B				LOUIS ALLIS			
				A WORLDWIDE ELECTRIC COMPANY			

Model:	LAM2-18-145T	Encl:	TEFC	Type:	AEH3
HP:	2	Poles	4	FR:	143/5T
Hz:	60	CODE:	L	Ins:	F
Volts:	230/460	P.F.:	0.8	HP:	2
Amps:	5.4/2.7	Eff:	0.865	Design:	B
RPM:	1730	S.F.:	1.25	DE BRG:	6205 ZZ
				ODE BRG:	6204 ZZ
				WT:	58.4 lbs.
				S.F.:	1.00