

DATA SHEET

Premium Efficiency Motor: **LAM3-12-213T**

60 Hz

WorldWide Electric Corporation

1 (800) 808-2131

Worldwideelectric.net



Document Generated: 8-Sep-2023
Document ID:

Customer:

MOTOR INFORMATION	
HP	3
RPM	1200
Phase	3
Frequency	60 Hz
Voltage	230/460
Frame Size	213/5T
Enclosure	TEFC
Degree of Protection	IP55
Service Factor	1.25
Poles	6
Full Load Speed	1175
Insulation Class	F
Temp Rise	80°C
NEMA Code Letter	K
Duty Cycle	S1 / Continuous
Slip	2.08%
NEMA Design	B
Moment of Inertia	0.785 lb.ft.^2
Locked Rotor Time (Hot)	12 seconds
Sound Pressure Level	71 dB(A)
Number of Starts	2 Cold/1 Hot
Max Ambient Temperature	40°C
Max Elevation	1000 m.a.s.l (3300 f.a.s.l)
Mounting	Rigid
Rotation	Bi-Directional
Area of Classification	Class 1 Division 2 Groups A,B,C,D T3B
Inverter Rating	10:1 CT / 20:1 VT
Standard	NEMA MG-1
Approvals	UL, CE, IEEE45, ABS

EFFICIENCY/POWER FACTOR		
LOAD	EFF	P. F.
100%	89.5 %	0.75
75%	89.6 %	0.68
50%	87.9 %	0.56

TORQUE		
FULL LOAD	LRT	BDT
13.17 lb.ft.	242 %	429 %

AMPERAGE INFORMATION		
	230V	460V
Full Load Amps	8.2A	4.1A
Locked Rotor Amps	64.6A	32.3A
No Load Current	4.4A	2.2A
Usable at 208V		9.1 A

BEARING INFORMATION	
DE Bearing	6308 ZZ
ODE Bearing	6306 ZZ
Grease Type	NSK SN7
DE Regreasing Interval	-- Hours
ODE Regreasing Interval	-- Hours
Grease Quantity	--

ADDITIONAL DATA	
F2 Suitable	Yes
Shaft Material	AISI 1045
Connection Diagram	9 Lead Wye
Approximate Weight	169 lbs.

MOTOR DRAWING

Premium Efficiency Motor: **LAM3-12-213T**

WorldWide Electric Corporation

1 (800) 808-2131

Worldwideelectric.net

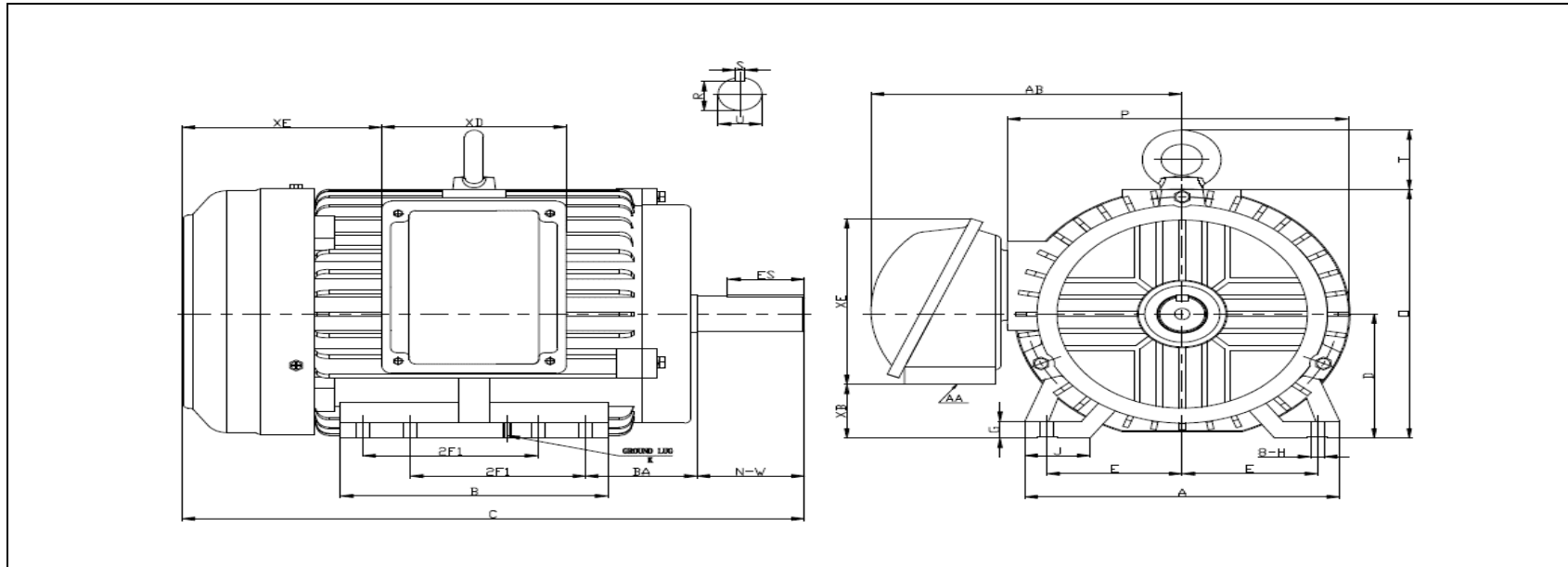

DIMENSION - INCHES

MOUNTING					A	B	C	D	G	J	P	O	T	AB
E	2F1	2F2	H	BA										
4.25	5.5	7	0.43	3.5	9.88	8.405	19.8	5.25	0.708	1.91	10.8	10.53	1.72	9.8

SHAFT & KEY				
S	ES	R	N-W	U
0.31	2.41	1.201	3.38	1.375

TERMINAL BOX				
AA	XB	XC	XD	XE
1 NPT	2.25	7.9	5.8	6.5

GROUND LUG
M5

PERFORMANCE CURVES

Premium Efficiency Motor:

LAM3-12-213T

WorldWide Electric Corporation

1 (800) 808-2131

Worldwideelectric.net



Document Generated: 8-Sep-2023
Document ID:

Customer:

Motor Type	AEH3		FL Speed	1175	
Output Rating (HP)	3		LRT (%FLT)	242	
Full Load Torque	13.17	lb.ft	460 volt FLA	4.1	
Rotor Wk ²	0.785	lb-ft ²	230 volt FLA	8.2	
			BDT (%FLT)	429	

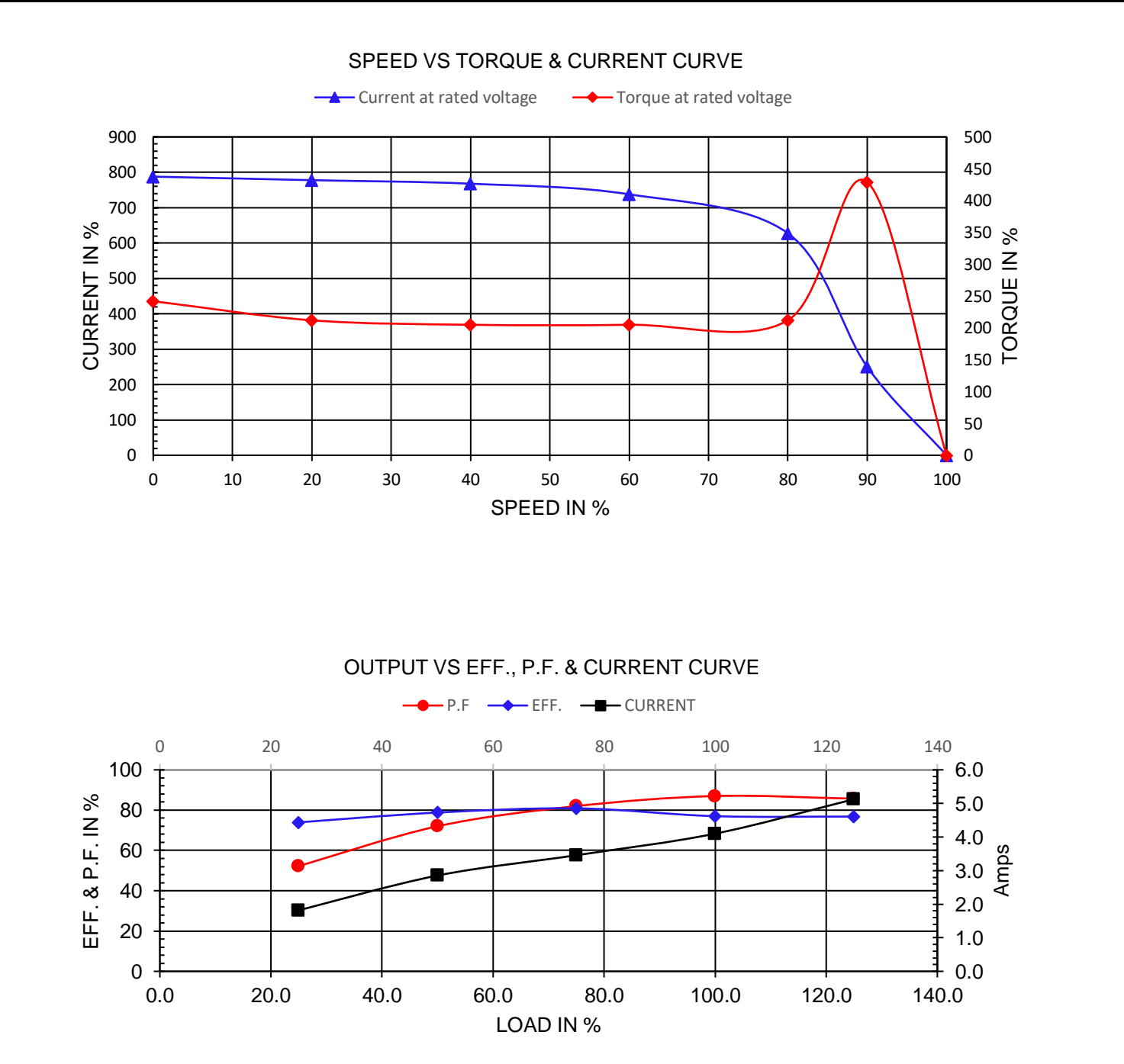

NAMEPLATE / WIRING

Premium Efficiency Motor: **LAM3-12-213T**

WorldWide Electric Corporation

1 (800) 808-2131

Worldwideelectric.net



Document Generated: 8-Sep-2023
Document ID:

Customer:

SAMPLE NAMEPLATE DATA

		THREE PHASE SEVERE DUTY MOTOR I EEE45																						
Model :		Encl :	Type :	SN :			<table style="width: 100%; text-align: center;"> <tr><td>4</td><td>5</td><td>6</td></tr> <tr><td>7</td><td>8</td><td>9</td></tr> <tr><td>↓1</td><td>↓2</td><td>↓3</td></tr> <tr><td>L1</td><td>L2</td><td>L3</td></tr> <tr><td colspan="3">230 V</td></tr> </table>			4	5	6	7	8	9	↓1	↓2	↓3	L1	L2	L3	230 V		
4	5	6																						
7	8	9																						
↓1	↓2	↓3																						
L1	L2	L3																						
230 V																								
HP :	Poles :	FR :	Ins :	Duty: Cont	IP :	Max Amb 40°C																		
Hz :		CODE :	Hz :		Design :																			
Volts :		P.F :	Volts :		DE BRG :																			
Amps :		Eff :	Amps :		ODE BRG :																			
RPM :		S.F :	RPM :		WT :																			
			S.F :		Date :																			
CC306B					LOUIS ALLIS				UL certified Class I, Division II, Groups A,B,C,D T3B															
					A WORLDWIDE ELECTRIC COMPANY																			

Model:	LAM3-12-213T	Encl:	TEFC	Type:	AEH3	
HP:	3	Poles	6	FR:	213/5T	IP: 55
Hz:	60	CODE:	K	Hz	50	HP: 3
Volts:	230/460	P.F:	0.75	Volts:	190/380	Design: B
Amps:	8.2/4.1	Eff:	0.895	Amps	9.8/4.9	DE BRG: 6308 ZZ
RPM:	1175	S.F:	1.25	RPM	975	ODE BRG: 6306 ZZ
				S.F:	1.00	WT: 169 lbs.