

DATA SHEET

Premium Efficiency Motor: **LAM3-18-182TCRD**

60 Hz

WorldWide Electric Corporation

1 (800) 808-2131

Worldwideelectric.net



Document Generated: 14-Sep-2023
Document ID:

Customer:

MOTOR INFORMATION	
HP	3
RPM	1800
Phase	3
Frequency	60 Hz
Voltage	230/460
Frame Size	182/4TC
Enclosure	TEFC
Degree of Protection	IP55
Service Factor	1.25
Poles	4
Full Load Speed	1750
Insulation Class	F
Temp Rise	80°C
NEMA Code Letter	K
Duty Cycle	S1 / Continuous
Slip	2.78%
NEMA Design	B
Moment of Inertia	0.36 lb.ft.^2
Locked Rotor Time (Hot)	12 seconds
Sound Pressure Level	74 dB(A)
Number of Starts	2 Cold/1 Hot
Max Ambient Temperature	40°C
Max Elevation	1000 m.a.s.l (3300 f.a.s.l)
Mounting	F1
Rotation	Bi-Directional
Area of Classification	Class 1 Division 2 Groups A,B,C,D T3B
Inverter Rating	10:1 CT / 20:1 VT
Standard	NEMA MG-1
Approvals	UL, CE, IEEE45, ABS

EFFICIENCY/POWER FACTOR		
LOAD	EFF	P. F.
100%	89.5 %	0.81
75%	89.4 %	0.75
50%	88.1 %	0.64

TORQUE		
FULL LOAD	LRT	BDT
8.8 lb.ft.	421 %	481 %

AMPERAGE INFORMATION		
	230V	460V
Full Load Amps	7.6A	3.8
Locked Rotor Amps	67.4A	33.7A
No Load Current	3.6A	1.8A
Usable at 208V		8.4 A

BEARING INFORMATION	
DE Bearing	6306 ZZ
ODE Bearing	6305 ZZ
Grease Type	NSK SN7
DE Regreasing Interval	-- Hours
ODE Regreasing Interval	-- Hours
Grease Quantity	--

ADDITIONAL DATA	
F2 Suitable	Yes
Shaft Material	AISI 1045
Connection Diagram	9 Lead Wye
Approximate Weight	91.9 lbs.

MOTOR DRAWING

Premium Efficiency Motor: **LAM3-18-182TRD**

WorldWide Electric Corporation

1 (800) 808-2131

Worldwideelectric.net

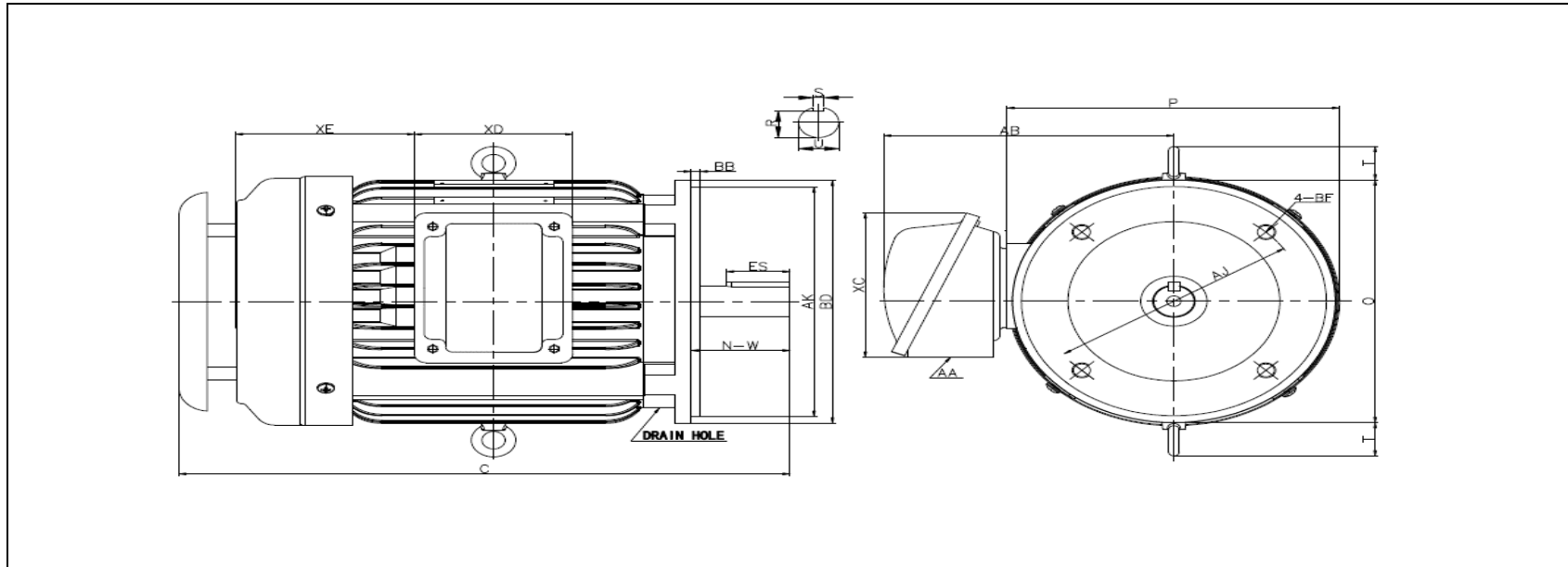

DIMENSION - INCHES

FLANGE MOUNTING					C	P	O	T	AB
AK	BD	AJ	BF	BB					
8.5	9	7.25	4*1/2-13	0.25	17.4	9.37	9.17	1.4	7.5

SHAFT & KEY				
S	ES	R	N-W	U
0.25	1.78	0.986	2.75	1.125

TERMINAL BOX			
AA	XC	XD	XE
3/4 NPT	5.2	4.4	4.9

PERFORMANCE CURVES

Premium Efficiency Motor:

LAM3-18-182CRD

WorldWide Electric Corporation

1 (800) 808-2131

Worldwideelectric.net



Document Generated: 14-Sep-2023
Document ID:

Customer:

Motor Type	LAM		FL Speed	1750	
Output Rating (HP)	3		LRT (%FLT)	421	460 volt FLA 3.8
Full Load Torque	8.8	lb.ft	BDT (%FLT)	481	230 volt FLA 7.6A
Rotor Wk^2	0.36	lb-ft^2			

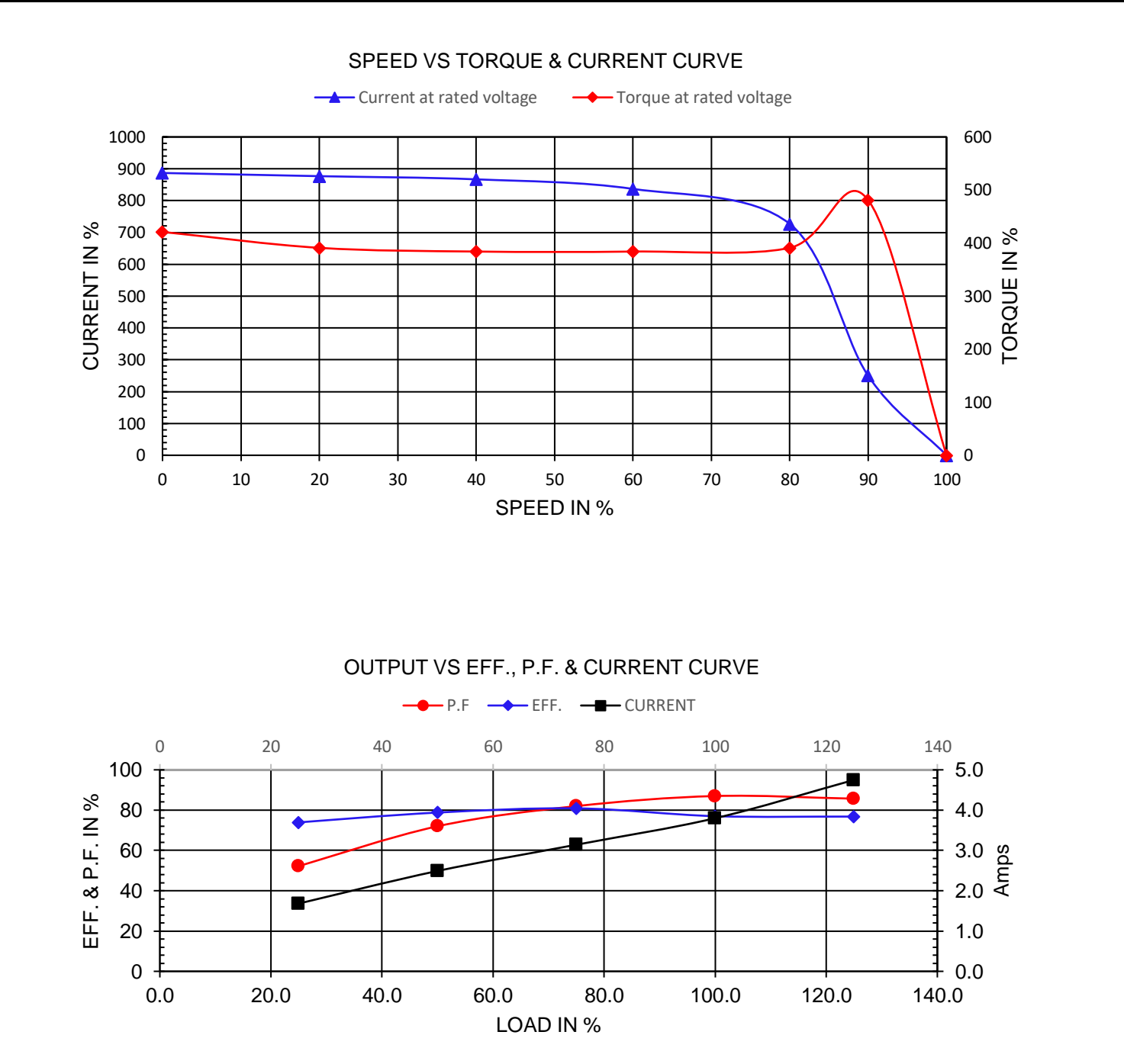

NAMEPLATE / WIRING

Premium Efficiency Motor: **LAM3-18-182TCRD**

WorldWide Electric Corporation

1 (800) 808-2131

Worldwideelectric.net



Document Generated: 14-Sep-2023
Document ID:

Customer:

SAMPLE NAMEPLATE DATA

		THREE PHASE SEVERE DUTY MOTOR							
Model :		Encl :	Type :		SN :				
HP :	Poles :	FR :	Ins:	Duty:	Cont	IP :	Max Amb 40°C		
Hz :		CODE :		Hz :		Design :			230 V
Volts :		P.F. :		Volts :		DE BRG :			460 V
Amps :		Eff :		Amps :		ODE BRG :			WT :
RPM :		S.F. :		RPM :		Date :			UL certified Class I, Division II, Groups A,B,C,D T3B
CC306B				LOUIS ALLIS		A WORLDWIDE ELECTRIC COMPANY			

Model:	LAM3-18-182TCRD	Encl:	TEFC	Type:	AEH3		
HP:	3	Poles	4	FR:	182/4TC	Ins:	F
Hz:	60	CODE:	K	Hz	50	HP:	3
Volts:	230/460	P.F.:	0.81	Volts:	190/380	Design:	B
Amps:	7.6/3.8	Eff:	0.895	Amps	9.2/4.6	ODE BRG:	6305 ZZ
RPM:	1750	S.F.:	1.25	RPM	1430	WT:	91.9 lbs.
				S.F.:	1.00		