

DATA SHEET

Premium Efficiency Motor: **LAM30-18-286T**

60 Hz

WorldWide Electric Corporation

1 (800) 808-2131

Worldwideelectric.net



Document Generated: 8-Sep-2023
Document ID:

Customer:

MOTOR INFORMATION	
HP	30
RPM	1800
Phase	3
Frequency	60 Hz
Voltage	230/460
Frame Size	284/6T
Enclosure	TEFC
Degree of Protection	IP55
Service Factor	1.25
Poles	4
Full Load Speed	1770
Insulation Class	F
Temp Rise	80°C
NEMA Code Letter	G
Duty Cycle	S1 / Continuous
Slip	1.67%
NEMA Design	B
Moment of Inertia	3.69 lb.ft.^2
Locked Rotor Time (Hot)	12 seconds
Sound Pressure Level	88 dB(A)
Number of Starts	2 Cold/1 Hot
Max Ambient Temperature	40°C
Max Elevation	1000 m.a.s.l (3300 f.a.s.l)
Mounting	Rigid
Rotation	Bi-Directional
Area of Classification	Class 1 Division 2 Groups A,B,C,D T3B
Inverter Rating	10:1 CT / 20:1 VT
Standard	NEMA MG-1
Approvals	UL, CE, IEEE45, ABS

EFFICIENCY/POWER FACTOR		
LOAD	EFF	P. F.
100%	93.6 %	0.83
75%	94.0 %	0.79
50%	93.7 %	0.69

TORQUE		
FULL LOAD	LRT	BDT
87.33 lb.ft.	266 %	311 %

AMPERAGE INFORMATION		
	230V	460V
Full Load Amps	71.4A	35.7A
Locked Rotor Amps	441.8A	220.9A
No Load Current	27.2A	13.6A
Usable at 208V		79 A

BEARING INFORMATION	
DE Bearing	6311 C3
ODE Bearing	6310 C3
Grease Type	Mobil Polyrex EM
DE Regreasing Interval	2400 Hours
ODE Regreasing Interval	3600 Hours
Grease Quantity	17g/15g

ADDITIONAL DATA	
F2 Suitable	Yes
Shaft Material	AISI 1045
Connection Diagram	12 Lead Delta
Approximate Weight	459.7 lbs.

MOTOR DRAWING

Premium Efficiency Motor: **LAM30-18-286T**

WorldWide Electric Corporation

1 (800) 808-2131

Worldwideelectric.net

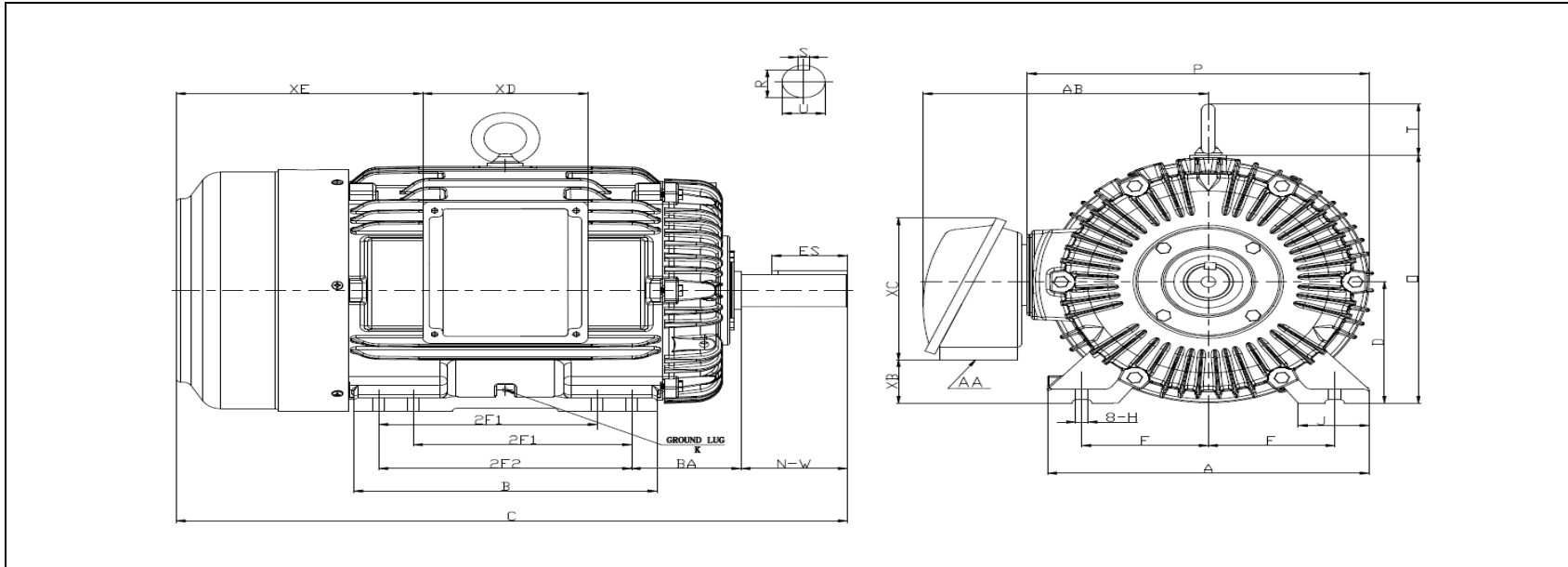

DIMENSION - INCHES

MOUNTING					A	B	C	D	G	J	P	O	T	AB
E	2F1	2F2	H	BA										
5.5	9.5	11	0.53	4.75	13.97	13.18	29.1	7	0.7795	3.07	14.56	14.04	2.42	12.02

SHAFT & KEY				
S	ES	R	N-W	U
0.5	3.28	1.59	4.62	1.875

TERMINAL BOX				
AA	XB	XC	XD	XE
1-1/2 NPT	2.75	8.17	6.85	10.3

GROUND LUG
M8

PERFORMANCE CURVES

Premium Efficiency Motor:

LAM30-18-286T

WorldWide Electric Corporation

1 (800) 808-2131

Worldwideelectric.net



Document Generated: 8-Sep-2023	Customer:
Document ID:	

Motor Type	AEH3		FL Speed	1770	
Output Rating (HP)	30		LRT (%FLT)	266	
Full Load Torque	87.33	lb.ft	460 volt FLA	35.7	
Rotor Wk ²	3.69	lb-ft ²	230 volt FLA	71.4	
			BDT (%FLT)	311	

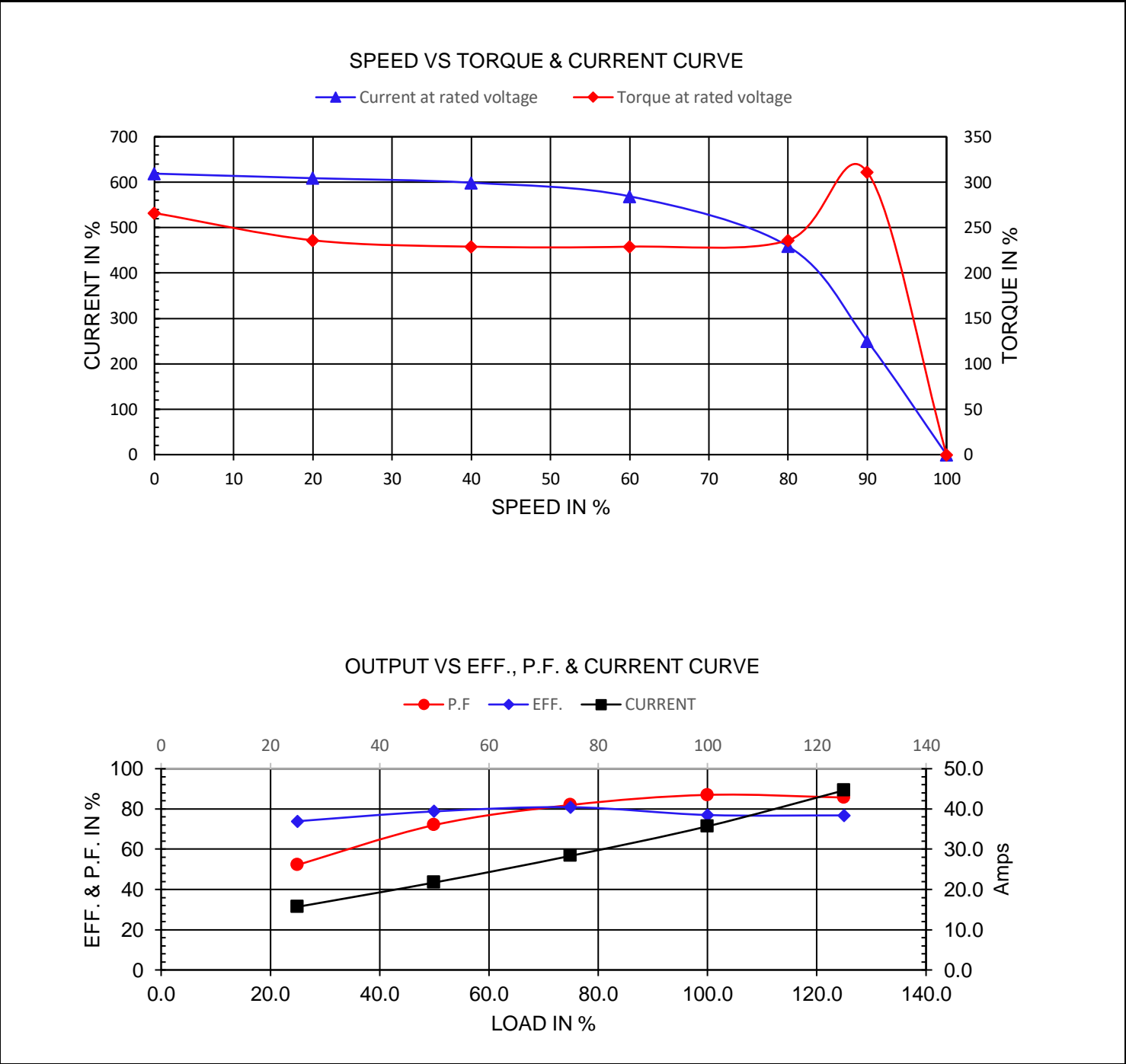

NAMEPLATE / WIRING

Premium Efficiency Motor: **LAM30-18-286T**

WorldWide Electric Corporation

1 (800) 808-2131

Worldwideelectric.net



Document Generated: 8-Sep-2023
Document ID:

Customer:

SAMPLE NAMEPLATE DATA

		THREE PHASE SEVERE DUTY MOTOR I EEE45																									
Model :		Encl :		Type :		SN :		<table border="0"> <tr><td>7</td><td>8</td><td>9</td></tr> <tr><td>6</td><td>4</td><td>5</td></tr> <tr><td>12</td><td>10</td><td>11</td></tr> <tr><td>1</td><td>2</td><td>3</td></tr> <tr><td>L1</td><td>L2</td><td>L3</td></tr> <tr><td colspan="3" style="text-align: center;">230 V</td></tr> </table>		7	8	9	6	4	5	12	10	11	1	2	3	L1	L2	L3	230 V		
7	8	9																									
6	4	5																									
12	10	11																									
1	2	3																									
L1	L2	L3																									
230 V																											
HP :	Poles :	FR:	Ins:	Duty: Cont	IP :	Max Amb 40°C		<table border="0"> <tr><td>7</td><td>8</td><td>9</td></tr> <tr><td>4</td><td>5</td><td>6</td></tr> <tr><td>12</td><td>10</td><td>11</td></tr> <tr><td>1</td><td>2</td><td>3</td></tr> <tr><td>L1</td><td>L2</td><td>L3</td></tr> <tr><td colspan="3" style="text-align: center;">460 V</td></tr> </table>		7	8	9	4	5	6	12	10	11	1	2	3	L1	L2	L3	460 V		
7	8	9																									
4	5	6																									
12	10	11																									
1	2	3																									
L1	L2	L3																									
460 V																											
Hz :	CODE :		Hz :	HP :	Design :		<p>UL certified Class I, Division II, Groups A,B,C,D T3B</p>																				
Volts :	P.F :		Volts :	DE BRG :																							
Amps :	Eff :		Amps :	ODE BRG :																							
RPM :	S.F :		RPM :	WT :																							
CC306B				LOUIS ALLIS A WORLDWIDE ELECTRIC COMPANY																							

Model:	LAM30-18-286T	Encl:	TEFC	Type:	AEH3	
HP:	30	Poles	4	FR:	284/6T	IP: 55
Hz:	60	CODE:	G	Hz	50	HP: 30
Volts:	230/460	P.F:	0.83	Volts:	190/380	Design: B
Amps:	71.4/35.7	Eff:	0.936	Amps	86.0/43.0	DE BRG: 6311 C3
RPM:	1770	S.F:	1.25	RPM	1460	ODE BRG: 6310 C3
				S.F:	1.00	WT: 459.7 lbs.