

DATA SHEET

Premium Efficiency Motor: **LAM30-36-286TS**

60 Hz

WorldWide Electric Corporation

1 (800) 808-2131

Worldwideelectric.net



Document Generated: 8-Sep-2023
Document ID:

Customer:

MOTOR INFORMATION	
HP	30
RPM	3600
Phase	3
Frequency	60 Hz
Voltage	230/460
Frame Size	284/6TS
Enclosure	TEFC
Degree of Protection	IP55
Service Factor	1.25
Poles	2
Full Load Speed	3560
Insulation Class	F
Temp Rise	80°C
NEMA Code Letter	G
Duty Cycle	S1 / Continuous
Slip	1.11%
NEMA Design	B
Moment of Inertia	2.525 lb.ft.^2
Locked Rotor Time (Hot)	12 seconds
Sound Pressure Level	94 dB(A)
Number of Starts	2 Cold/1 Hot
Max Ambient Temperature	40°C
Max Elevation	1000 m.a.s.l (3300 f.a.s.l)
Mounting	Rigid
Rotation	Bi-Directional
Area of Classification	Class 1 Division 2 Groups A,B,C,D T3B
Inverter Rating	10:1 CT / 20:1 VT
Standard	NEMA MG-1
Approvals	UL, CE, IEEE45, ABS

EFFICIENCY/POWER FACTOR		
LOAD	EFF	P. F.
100%	91.7 %	0.89
75%	93.4 %	0.89
50%	92.8 %	0.85

TORQUE		
FULL LOAD	LRT	BDT
43.4 lb.ft.	386 %	399 %

AMPERAGE INFORMATION		
	230V	460V
Full Load Amps	66.4A	33.2A
Locked Rotor Amps	470.6A	235.3A
No Load Current	13.6A	6.8A
Usable at 208V		73.4 A

BEARING INFORMATION	
DE Bearing	6311 C3
ODE Bearing	6310 C3
Grease Type	Mobil Polyrex EM
DE Regreasing Interval	2400 Hours
ODE Regreasing Interval	3600 Hours
Grease Quantity	17g/15g

ADDITIONAL DATA	
F2 Suitable	Yes
Shaft Material	AISI 1045
Connection Diagram	12 Lead Delta
Approximate Weight	396.8 lbs.

MOTOR DRAWING

Premium Efficiency Motor: **LAM30-36-286TS**

WorldWide Electric Corporation

1 (800) 808-2131

Worldwideelectric.net

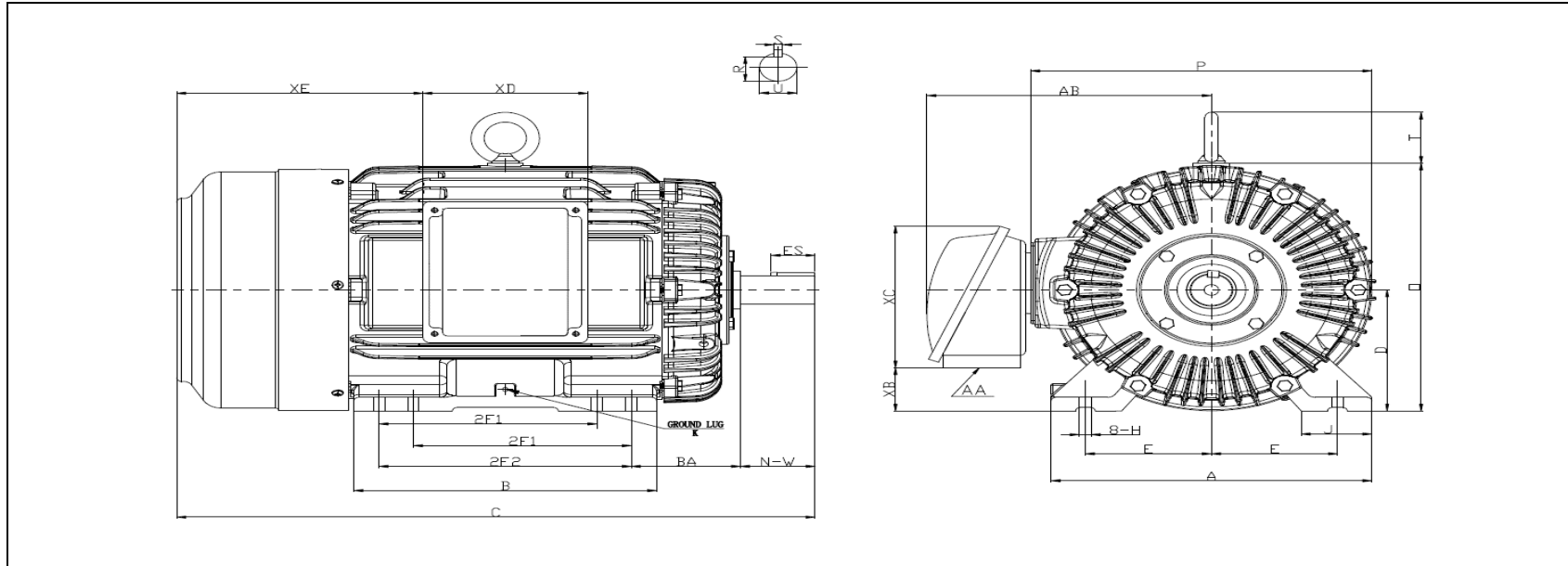

DIMENSION - INCHES

MOUNTING					A	B	C	D	G	J	P	O	T	AB
E	2F1	2F2	H	BA										
5.5	9.5	11	0.53	4.75	13.97	13.18	27.73	7	0.7795	3.07	14.56	14.04	2.42	12.02

SHAFT & KEY				
S	ES	R	N-W	U
0.375	1.91	1.416	3.25	1.625

TERMINAL BOX				
AA	XB	XC	XD	XE
1-1/2 NPT	2.75	8.17	6.85	10.3

GROUND LUG
M8

PERFORMANCE CURVES

WorldWide Electric Corporation

1 (800) 808-2131

Worldwideelectric.net



Premium Efficiency Motor:

LAM30-36-286TS

Document Generated: 8-Sep-2023
Document ID:

Customer:

Motor Type	AEH3		FL Speed	3560	
Output Rating (HP)	30		LRT (%FLT)	386	460 volt FLA 33.2
Full Load Torque	43.4	lb.ft	BDT (%FLT)	399	230 volt FLA 66.4
Rotor Wk ²	2.525	lb-ft ²			

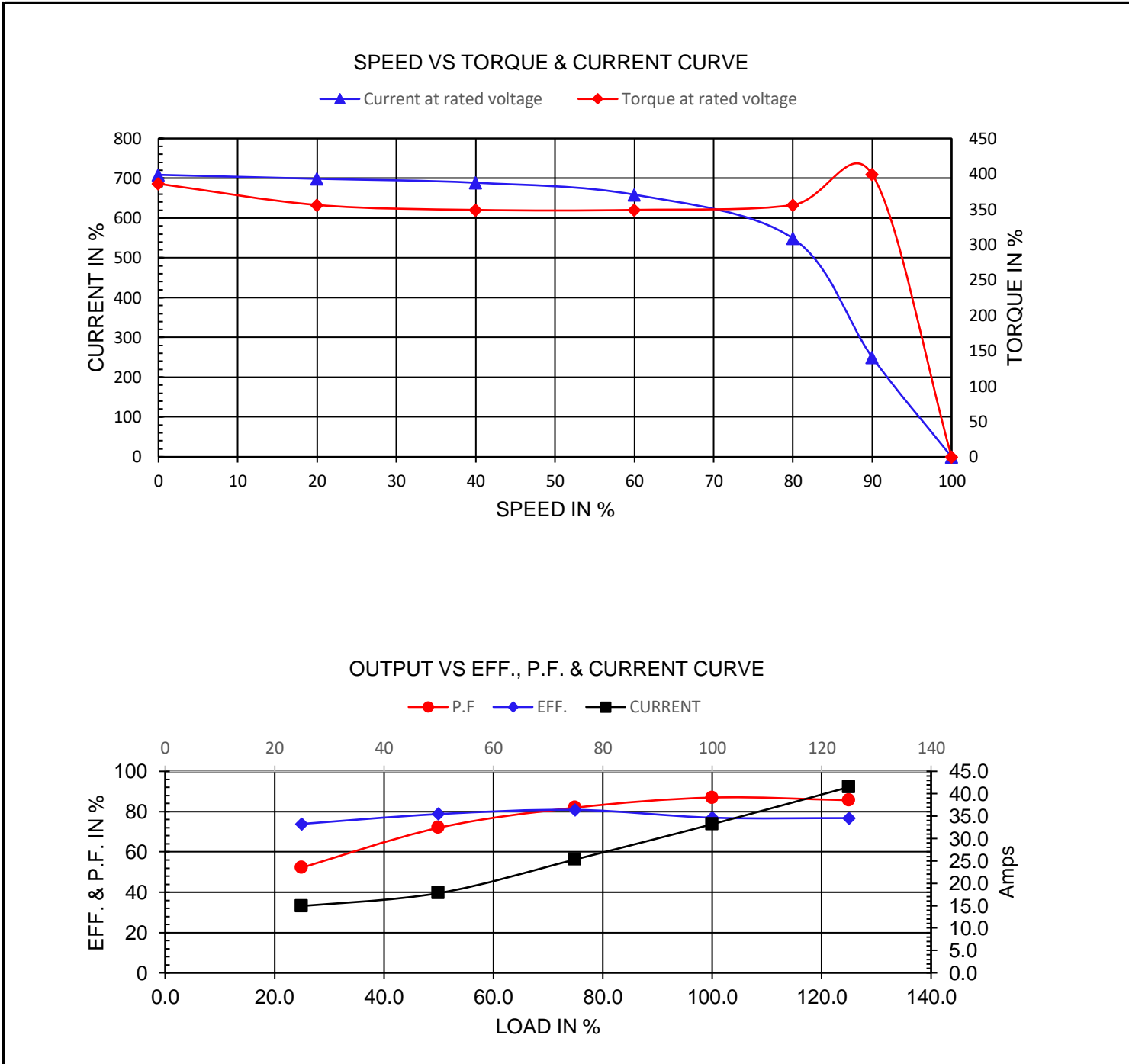

NAMEPLATE / WIRING

Premium Efficiency Motor: **LAM30-36-286TS**

WorldWide Electric Corporation

1 (800) 808-2131

Worldwideelectric.net



Document Generated: 8-Sep-2023
Document ID:

Customer:

SAMPLE NAMEPLATE DATA

		THREE PHASE SEVERE DUTY MOTOR I EEE45																																											
Model :		Encl :		Type :		SN :		<table style="width: 100%; text-align: center;"> <tr> <td>7</td><td>8</td><td>9</td></tr> <tr> <td>6</td><td>4</td><td>5</td></tr> <tr> <td>12</td><td>10</td><td>11</td></tr> <tr> <td>1</td><td>2</td><td>3</td></tr> <tr> <td>L1</td><td>L2</td><td>L3</td></tr> <tr> <td colspan="3">230 V</td></tr> <tr> <td>7</td><td>8</td><td>9</td></tr> <tr> <td>4</td><td>5</td><td>6</td></tr> <tr> <td>12</td><td>10</td><td>11</td></tr> <tr> <td>1</td><td>2</td><td>3</td></tr> <tr> <td>L1</td><td>L2</td><td>L3</td></tr> <tr> <td colspan="3">460 V</td></tr> </table>		7	8	9	6	4	5	12	10	11	1	2	3	L1	L2	L3	230 V			7	8	9	4	5	6	12	10	11	1	2	3	L1	L2	L3	460 V		
7	8	9																																											
6	4	5																																											
12	10	11																																											
1	2	3																																											
L1	L2	L3																																											
230 V																																													
7	8	9																																											
4	5	6																																											
12	10	11																																											
1	2	3																																											
L1	L2	L3																																											
460 V																																													
HP :	Poles :	FR:	Ins:	Duty: Cont	IP :	Max Amb 40°C																																							
Hz :	CODE :		Hz :	HP :	Design :																																								
Volts :	P.F :		Volts :	DE BRG :																																									
Amps :	Eff :		Amps :	ODE BRG :																																									
RPM :	S.F :		RPM :	WT :																																									
			S.F :	Date :		UL certified Class I, Division II, Groups A,B,C,D T3B																																							
CC306B		LOUIS ALLIS A WORLDWIDE ELECTRIC COMPANY																																											

Model:	LAM30-36-286TS	Encl:	TEFC	Type:	AEH3		
HP:	30	Poles	2	FR:	284/6TS	IP:	55
Hz:	60	CODE:	G	Hz	50	HP:	30
Volts:	230/460	P.F:	0.89	Volts:	190/380	Design:	B
Amps:	66.4/33.2	Eff:	0.917	Amps	81.8/40.9	DE BRG:	6311 C3
RPM:	3560	S.F:	1.25	RPM	2950	ODE BRG:	6310 C3
				S.F:	1.00	WT:	396.8 lbs.