

DATA SHEET

Premium Efficiency Motor: **LAM350-12-L449T**

60 Hz

WorldWide Electric Corporation

1 (800) 808-2131

Worldwideelectric.net



Document Generated: 8-Sep-2023
Document ID:

Customer:

MOTOR INFORMATION	
HP	350
RPM	1200
Phase	3
Frequency	60 Hz
Voltage	460
Frame Size	L447/9T
Enclosure	TEFC
Degree of Protection	IP55
Service Factor	1.15
Poles	6
Full Load Speed	1195
Insulation Class	F
Temp Rise	80°C
NEMA Code Letter	H
Duty Cycle	S1 / Continuous
Slip	0.52%
NEMA Design	A
Moment of Inertia	225.7 lb.ft.^2
Locked Rotor Time (Hot)	12 seconds
Sound Pressure Level	100 dB(A)
Number of Starts	2 Cold/1 Hot
Max Ambient Temperature	40°C
Max Elevation	1000 m.a.s.l (3300 f.a.s.l)
Mounting	Rigid
Rotation	Bi-Directional
Area of Classification	Class 1 Division 2 Groups A,B,C,D T3B
Inverter Rating	10:1 CT / 20:1 VT
Standard	NEMA MG-1
Approvals	UL, CE, IEEE45, ABS

EFFICIENCY/POWER FACTOR		
LOAD	EFF	P. F.
100%	95.8 %	0.83
75%	95.8 %	0.79
50%	95.2 %	0.7

TORQUE		
FULL LOAD	LRT	BDT
1541 lb.ft.	168 %	346 %

AMPERAGE INFORMATION		
	230V	460V
Full Load Amps	--A	410.6A
Locked Rotor Amps	--A	2885A
No Load Current	--A	160.9A
Usable at 208V		-- A

BEARING INFORMATION	
DE Bearing	NU320 C3
ODE Bearing	6320 C3
Grease Type	Mobil Polyrex EM
DE Regreasing Interval	2400 Hours
ODE Regreasing Interval	2400 Hours
Grease Quantity	51g/51g

ADDITIONAL DATA	
F2 Suitable	Yes
Shaft Material	4140
Connection Diagram	6 Lead Delta
Approximate Weight	4031 lbs.

MOTOR DRAWING

Premium Efficiency Motor: **LAM350-12-L449T**

WorldWide Electric Corporation

1 (800) 808-2131

Worldwideelectric.net

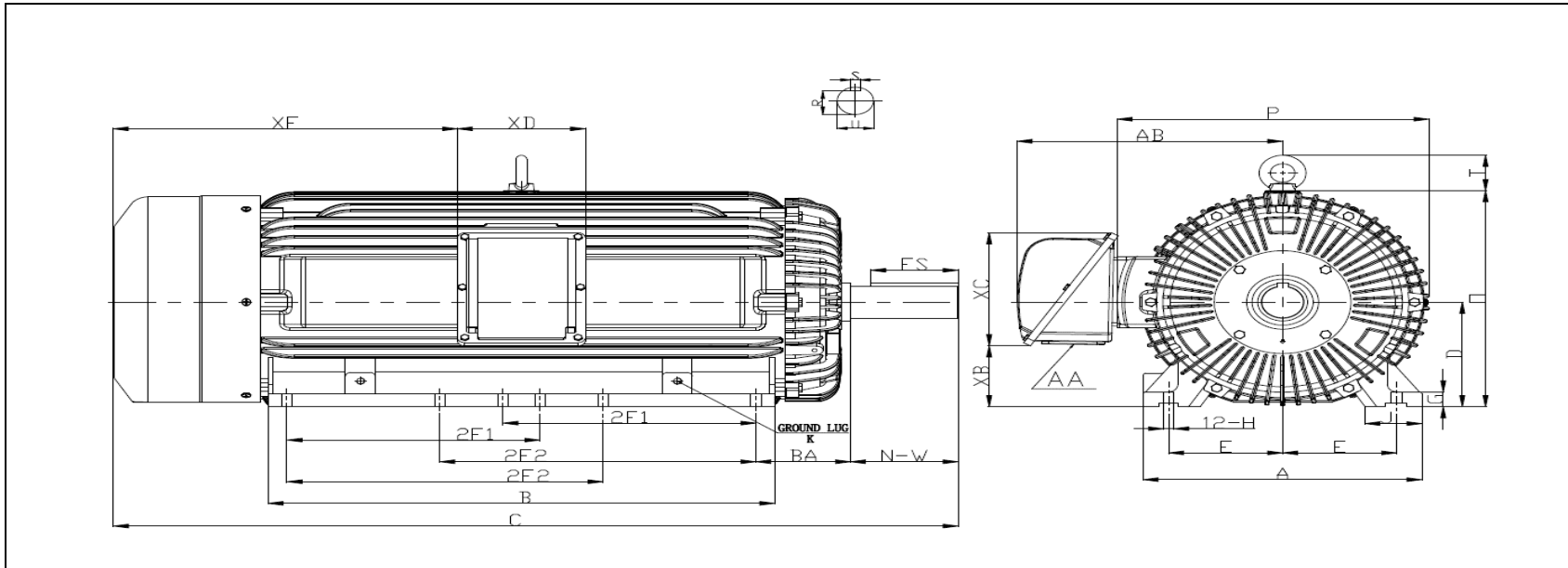

DIMENSION - INCHES

MOUNTING					A	B	C	D	G	J	P	O	T	AB
E	2F1	2F2	H	BA										
9	20	25	0.81	7.5	22	40	66.9	11	1.417	4.33	25.8	23.8	4.85	23.4

SHAFT & KEY				
S	ES	R	N-W	U
0.875	6.91	2.88	8.5	3.375

TERMINAL BOX				
AA	XB	XC	XD	XE
3 NPT	4.13	16.2	11.6	27.2

GROUND LUG
M12

PERFORMANCE CURVES

Premium Efficiency Motor:

LAM350-12-L449T

WorldWide Electric Corporation

1 (800) 808-2131

Worldwideelectric.net



Document Generated: 8-Sep-2023
Document ID:

Customer:

Motor Type	AEH3		FL Speed	1195	
Output Rating (HP)	350		LRT (%FLT)	168	460 volt FLA 410.6
Full Load Torque	1541 lb.ft		BDT (%FLT)	346	230 volt FLA --
Rotor Wk ²	225.7 lb-ft ²				

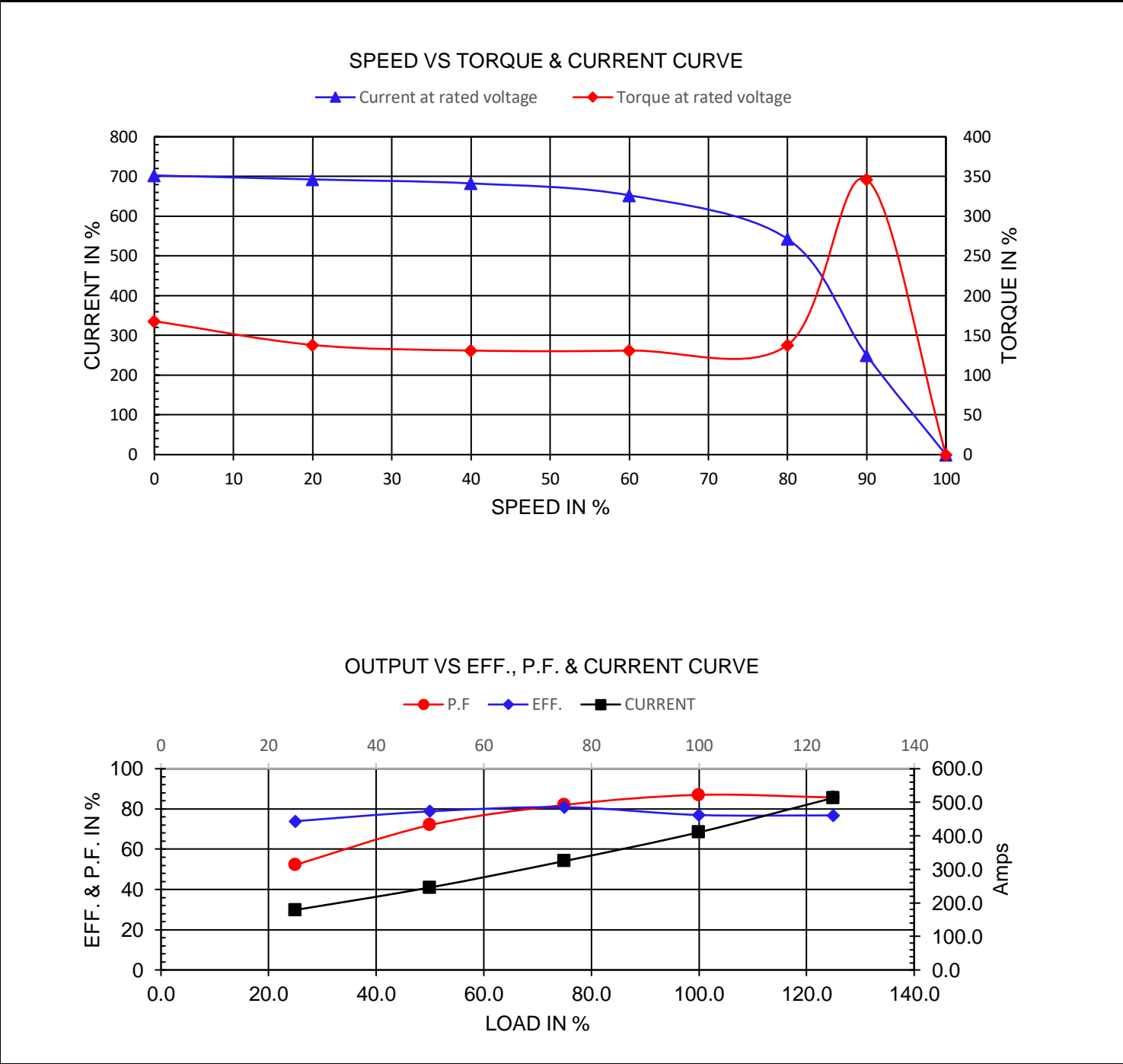

NAMEPLATE / WIRING

Premium Efficiency Motor: **LAM350-12-L449T**

WorldWide Electric Corporation

1 (800) 808-2131

Worldwideelectric.net



Document Generated: 8-Sep-2023
Document ID:

Customer:

SAMPLE NAMEPLATE DATA

		THREE PHASE SEVERE DUTY MOTOR IEEE45								
Model :			Encl :		Type :		SN :			
HP :	Poles :	FR:	Ins:	Duty: Cont	IP :	Max Amb 40°C				
Hz :	CODE :		Hz :	HP :	Design :					
Volts :	P.F :		Volts :	DE BRG :						
Amps :	Eff :		Amps :	ODE BRG :						
RPM :	S.F :		RPM :	WT :						
			S.F :	Date :						
CC306B		LOUIS ALLIS A WORLDWIDE ELECTRIC COMPANY								
UL certified Class I, Division II, Groups A,B,C,D T3B										

Model:	LAM350-12-L449T	Encl:	TEFC	Type:	AEH3		
HP:	350	Poles	6	FR:	L447/9T	IP:	55
Hz:	60	CODE:	H	Hz	50	HP:	300
Volts:	460	P.F:	0.83	Volts:	380	Design:	B
Amps:	410.6	Eff:	0.958	Amps	426	DE BRG:	NU320 C3
RPM:	1195	S.F:	1.15	RPM	995	ODE BRG:	6320 C3
				S.F:	1.00	WT:	4031 lbs.