

DATA SHEET

Premium Efficiency Motor: **LAM400-12-L449T-IB-F2**

60 Hz

WorldWide Electric Corporation

1 (800) 808-2131

Worldwideelectric.net



Document Generated: 8-Sep-2023
Document ID:

Customer:

MOTOR INFORMATION	
HP	400
RPM	1200
Phase	3
Frequency	60 Hz
Voltage	460
Frame Size	L447/9T
Enclosure	TEFC
Degree of Protection	IP55
Service Factor	1.15
Poles	6
Full Load Speed	1190
Insulation Class	F
Temp Rise	80°C
NEMA Code Letter	G
Duty Cycle	S1 / Continuous
Slip	0.68%
NEMA Design	--
Moment of Inertia	236.6 lb.ft.^2
Locked Rotor Time (Hot)	12 seconds
Sound Pressure Level	103 dB(A)
Number of Starts	2 Cold/1 Hot
Max Ambient Temperature	40°C
Max Elevation	1000 m.a.s.l (3300 f.a.s.l)
Mounting	Rigid
Rotation	Bi-Directional
Area of Classification	Class 1 Division 2 Groups A,B,C,D T3B
Inverter Rating	10:1 CT / 20:1 VT
Standard	NEMA MG-1
Approvals	UL, CE, IEEE45, ABS

EFFICIENCY/POWER FACTOR		
LOAD	EFF	P. F.
100%	95.8 %	0.85
75%	95.7 %	0.82
50%	95.3 %	0.74

TORQUE		
FULL LOAD	LRT	BDT
1763.1 lb.ft.	191 %	318 %

AMPERAGE INFORMATION		
	230V	460V
Full Load Amps	--A	461.5A
Locked Rotor Amps	--A	3114A
No Load Current	--A	156.5A
Usable at 208V		-- A

BEARING INFORMATION	
DE Bearing	NU320 C3
ODE Bearing	6320 C3-INS
Grease Type	Mobil Polyrex EM
DE Regreasing Interval	2400 Hours
ODE Regreasing Interval	2400 Hours
Grease Quantity	51g/51g

ADDITIONAL DATA	
F2 Suitable	Yes
Shaft Material	4140
Connection Diagram	6 Lead Delta
Approximate Weight	3999 lbs.

MOTOR DRAWING

Premium Efficiency Motor: **LAM400-12-L449T-IB-F2**

WorldWide Electric Corporation

1 (800) 808-2131

Worldwideelectric.net

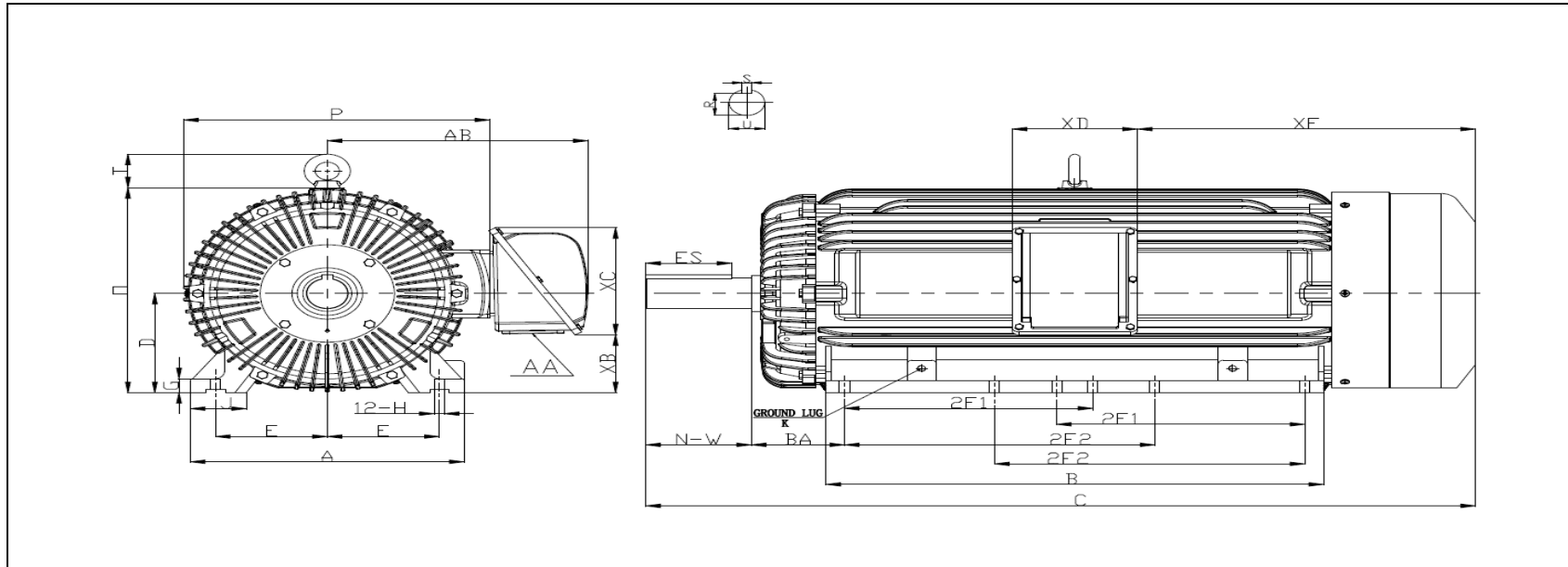

DIMENSION - INCHES

MOUNTING					A	B	C	D	G	J	P	O	T	AB
E	2F1	2F2	H	BA										
9	20	25	0.81	7.5	22	40	66.9	11	1.417	4.33	25.8	23.8	4.85	23.4

SHAFT & KEY				
S	ES	R	N-W	U
0.875	6.91	2.88	8.5	3.375

TERMINAL BOX				
AA	XB	XC	XD	XE
3 NPT	4.13	16.2	11.6	27.2

GROUND LUG
M12

PERFORMANCE CURVES

WorldWide Electric Corporation

1 (800) 808-2131

Worldwideelectric.net



Premium Efficiency Motor:

LAM400-12-L449T-IB-F2

Document Generated: 8-Sep-2023
Document ID:

Customer:

Motor Type	AEH3		FL Speed	1190	
Output Rating (HP)	400		LRT (%FLT)	191	460 volt FLA 461.5
Full Load Torque	1763.1 lb.ft		BDT (%FLT)	318	230 volt FLA --
Rotor Wk ²	236.6 lb-ft ²				

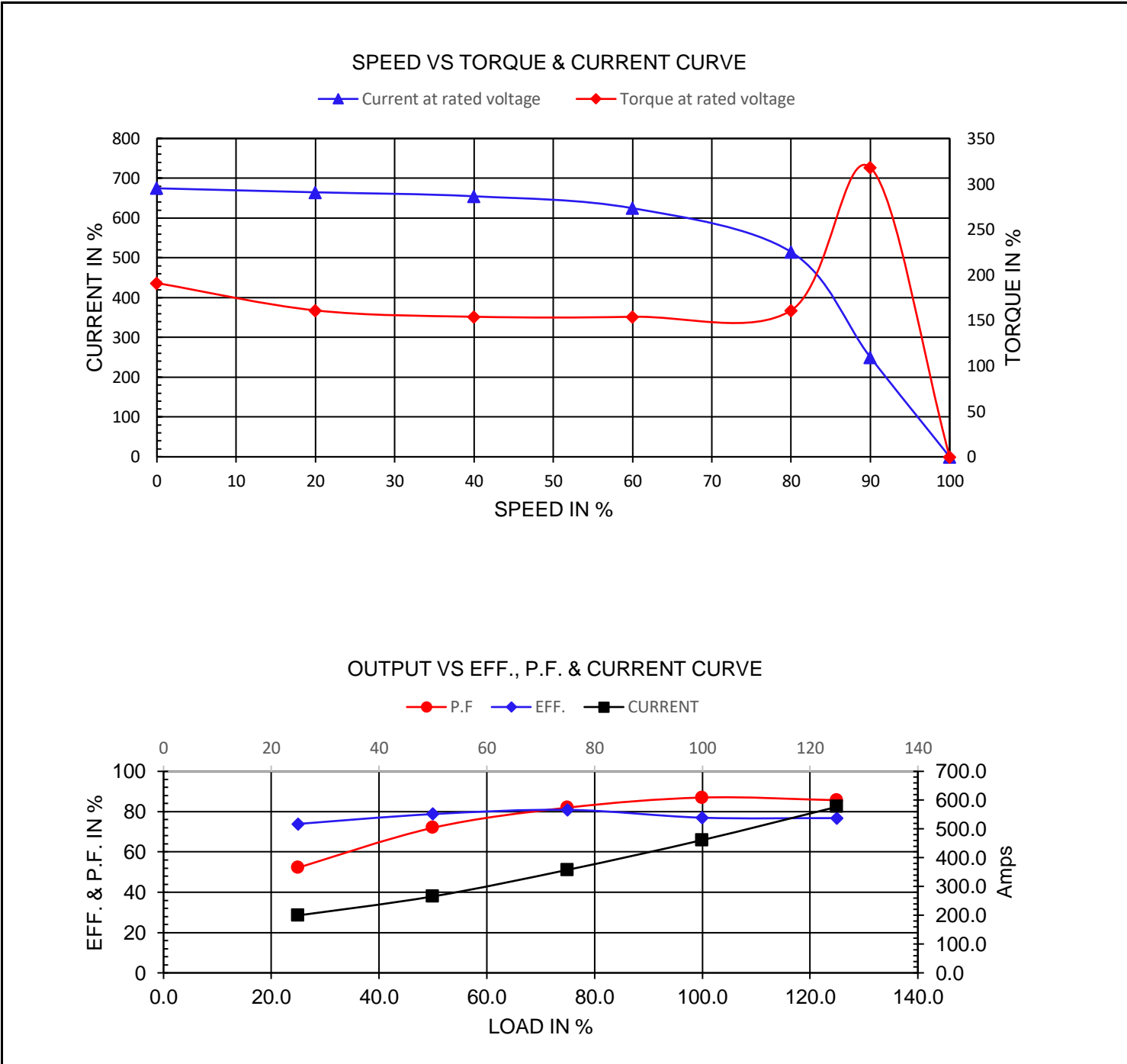

NAMEPLATE / WIRING

Premium Efficiency Motor: **LAM400-12-L449T-IB-F2**

WorldWide Electric Corporation

1 (800) 808-2131

Worldwideelectric.net



Document Generated: 8-Sep-2023
Document ID:

Customer:

SAMPLE NAMEPLATE DATA

THREE PHASE SEVERE DUTY MOTOR I EEE45							
Model :		Encl :	Type :	SN :			
HP :	Poles :	FR:	Ins:	Duty: Cont	IP :		Max Amb 40°C
Hz :	CODE :		Hz :	HP :	Design :		
Volts :	P.F. :		Volts :	DE BRG :			
Amps :	Eff :		Amps :	ODE BRG :			
RPM :	S.F. :		RPM :	WT :			
			S.F. :	Date :			
LOUIS ALLIS A WORLDWIDE ELECTRIC COMPANY							

Model:	LAM400-12-L449T-IB-F2	Encl:	TEFC	Type:	AEH3	
HP:	400	Poles	6	FR:	L447/9T	IP: 55
Hz:	60	CODE:	G	Hz	50	HP: 350
Volts:	460	P.F.:	0.85	Volts:	380	Design: B
Amps:	461.5	Eff:	0.958	Amps	486.3	DE BRG: NU320 C3
RPM:	1190	S.F.:	1.15	RPM	990	ODE BRG: 6320 C3-INS
				S.F.:	1.00	WT: 3999 lbs.