

DATA SHEET

Premium Efficiency Motor: **LAM7.5-18-213TC**

60 Hz

WorldWide Electric Corporation

1 (800) 808-2131

Worldwideelectric.net



Document Generated: 14-Sep-2023
Document ID:

Customer:

MOTOR INFORMATION	
HP	7.5
RPM	1800
Phase	3
Frequency	60 Hz
Voltage	230/460
Frame Size	213/5TC
Enclosure	TEFC
Degree of Protection	IP55
Service Factor	1.25
Poles	4
Full Load Speed	1750
Insulation Class	F
Temp Rise	80°C
NEMA Code Letter	H
Duty Cycle	S1 / Continuous
Slip	2.78%
NEMA Design	B
Moment of Inertia	0.716 lb.ft.^2
Locked Rotor Time (Hot)	12 seconds
Sound Pressure Level	79 dB(A)
Number of Starts	2 Cold/1 Hot
Max Ambient Temperature	40°C
Max Elevation	1000 m.a.s.l (3300 f.a.s.l)
Mounting	F1
Rotation	Bi-Directional
Area of Classification	Class 1 Division 2 Groups A,B,C,D T3B
Inverter Rating	10:1 CT / 20:1 VT
Standard	NEMA MG-1
Approvals	UL, CE, IEEE45, ABS

EFFICIENCY/POWER FACTOR		
LOAD	EFF	P. F.
100%	91.7 %	0.85
75%	92.3 %	0.80
50%	92.0 %	0.7

TORQUE		
FULL LOAD	LRT	BDT
21.9 lb.ft.	332 %	344 %

AMPERAGE INFORMATION		
	230V	460V
Full Load Amps	17.8A	8.9
Locked Rotor Amps	130.2A	65.1A
No Load Current	7A	3.5A
Usable at 208V	19.7 A	

BEARING INFORMATION	
DE Bearing	6308 ZZ
ODE Bearing	6306 ZZ
Grease Type	NSK SN7
DE Regreasing Interval	-- Hours
ODE Regreasing Interval	-- Hours
Grease Quantity	--

ADDITIONAL DATA	
F2 Suitable	Yes
Shaft Material	AISI 1045
Connection Diagram	9 Lead Wye
Approximate Weight	176.4 lbs.

MOTOR DRAWING

Premium Efficiency Motor: **LAM7.5-18-213TC**

WorldWide Electric Corporation

1 (800) 808-2131

Worldwideelectric.net

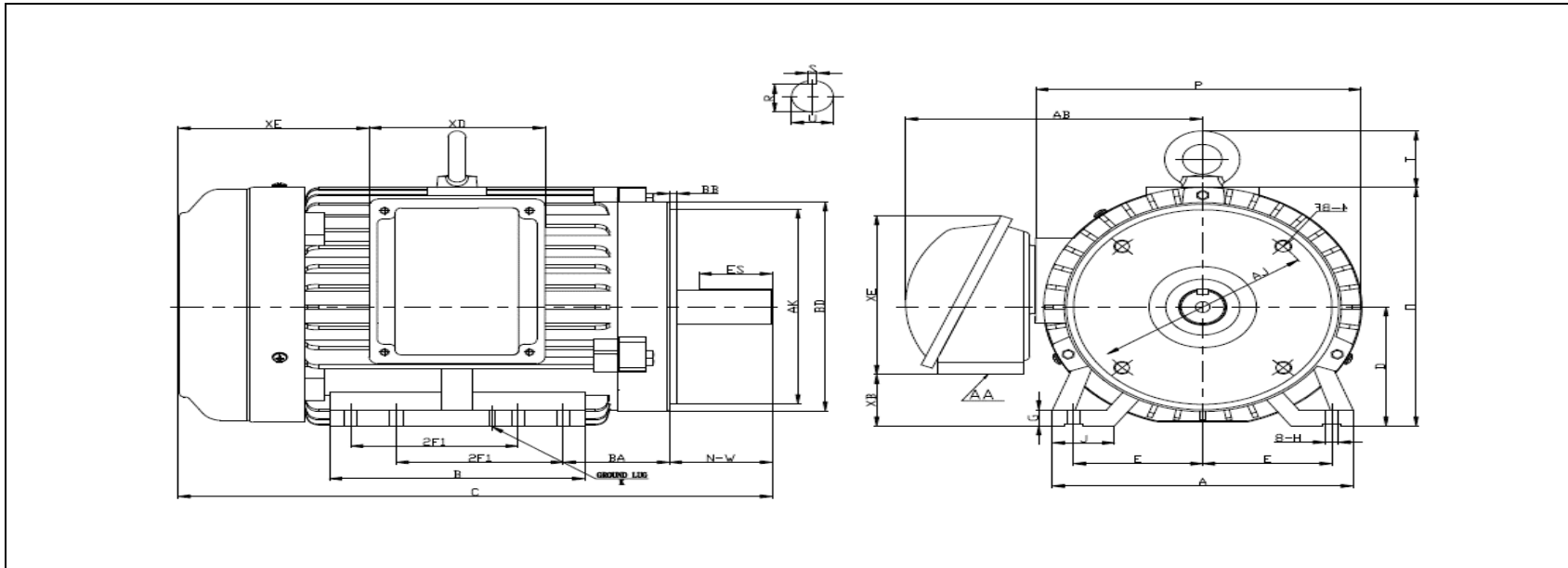

DIMENSION - INCHES

MOUNTING					A	B	C	D	G	P	O	T	AB
E	2F1	2F2	H	BA									
4.25	5.5	7	0.43	3.5	9.88	8.405	19.5	5.25	0.708	10.8	10.53	1.72	9.8

SHAFT & KEY				
S	ES	R	N-W	U
0.31	2.41	1.201	3.38	1.375

TERMINAL BOX				
AA	XB	XC	XD	XE
1 NPT	1.63	7.9	5.8	6.5

GROUND LUG
M5

FLANGE				
AK	BD	AJ	BF	BB
8.5	9	7.25	4*1/2-13	0.25

PERFORMANCE CURVES

Premium Efficiency Motor:

LAM7.5-18-213TC

WorldWide Electric Corporation

1 (800) 808-2131

Worldwideelectric.net



Document Generated: 14-Sep-2023
Document ID:

Customer:

Motor Type	LAM		FL Speed	1750	
Output Rating (HP)	7.5		LRT (%FLT)	332	460 volt FLA 8.9
Full Load Torque	21.9	lb.ft	BDT (%FLT)	344	230 volt FLA 17.8A
Rotor Wk ²	0.716	lb-ft ²			

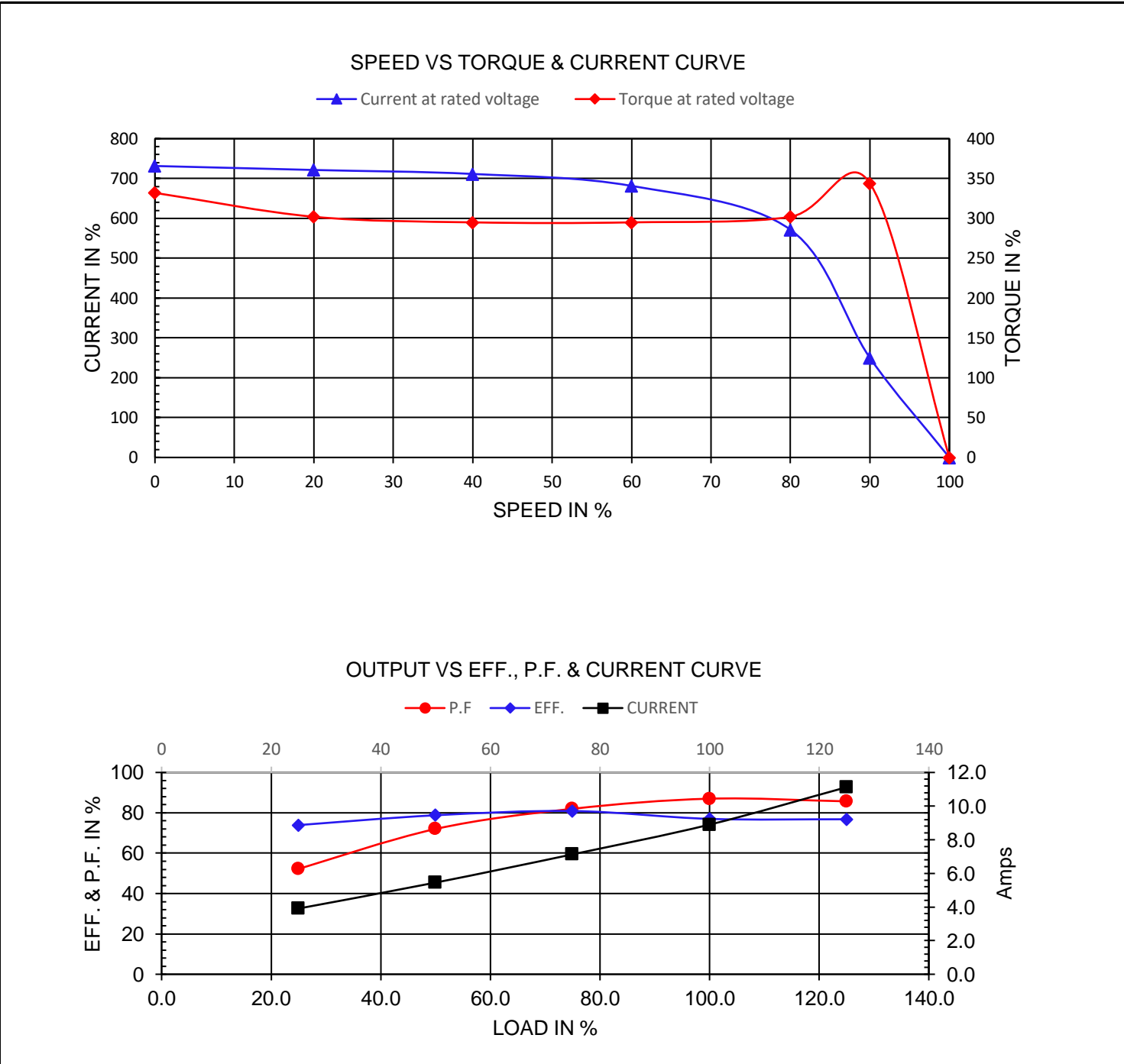

NAMEPLATE / WIRING

Premium Efficiency Motor: **LAM7.5-18-213TC**

WorldWide Electric Corporation

1 (800) 808-2131

Worldwideelectric.net



Document Generated: 14-Sep-2023
Document ID:

Customer:

SAMPLE NAMEPLATE DATA

		THREE PHASE SEVERE DUTY MOTOR IEE45																							
Model :		Encl :	Type :	SN :			<table style="width: 100%; text-align: center;"> <tr> <td>4</td><td>5</td><td>6</td> </tr> <tr> <td>7</td><td>8</td><td>9</td> </tr> <tr> <td>1</td><td>2</td><td>3</td> </tr> <tr> <td>L1</td><td>L2</td><td>L3</td> </tr> <tr> <td colspan="3">230 V</td> </tr> </table>				4	5	6	7	8	9	1	2	3	L1	L2	L3	230 V		
4	5	6																							
7	8	9																							
1	2	3																							
L1	L2	L3																							
230 V																									
HP :	Poles :	FR :	Ins :	Duty: Cont	IP :	Max Amb 40°C																			
Hz :		CODE :	Hz :		Design :																				
Volts :		P.F. :	Volts :		DE BRG :																				
Amps :		Eff :	Amps :		ODE BRG :																				
RPM :		S.F. :	RPM :		WT :																				
			S.F. :		Date :																				
CC306B		LOUIS ALLIS A WORLDWIDE ELECTRIC COMPANY			176				UL certified Class I, Division II, Groups A,B,C,D T3B																

Model:	LAM7.5-18-213TC	Encl:	TEFC	Type:	AEH3
HP:	7.5	Poles	4	FR:	213/5TC
Hz:	60	CODE:	H	Ins:	F
Volts:	230/460	P.F.:	0.85	HP:	7.5
Amps:	17.8/8.9	Eff:	0.917	Design:	B
RPM:	1750	S.F.:	1.25	DE BRG:	6308 ZZ
				ODE BRG:	6306 ZZ
				WT:	176.4 lbs.
				S.F.:	1.00