



WORLDWIDE ELECTRIC MOTOR DATA SHEET



OCCP25-36-256JM

HORSEPOWER	25		
RPM / POLES	3600 / 2		
VOLTAGE / PHASE	208 - 230 / 460 V / 3		
FRAME	256JM		
ENCLOSURE / DEGREE OF PROTECTION	ODP / IP23		
FREQUENCY	60 HZ Suitable For 50 HZ Operation With 1.0 SF		
FULL LOAD SPEED	3530 RPM		
SERVICE FACTOR	1.15 SF 60 HZ / 1.0 SF at 50 HZ		
INSULATION CLASS	F		
FULL LOAD AMPS; 230 / 460	54.0 / 27.0 A		
LOCKED ROTOR AMPS (STARTING); 230 / 460	402 / 201 A		
NO LOAD CURRENT	10.0 / 5.0 A		
NEMA CODE LETTER	H		
EFFICIENCY / POWER FACTOR	<u>LOAD</u>	<u>EFF.</u>	<u>P.F.</u>
	100%	91.7%	0.93
	75%	93.6%	0.92
	50%	93.9%	0.88
DUTY CYCLE	S1 / Continuous		
TORQUE	<u>FULL LOAD</u>	<u>LRT</u>	<u>BDT</u>
	37.0 lb.ft.	287.0%	347.0%
SLIP	1.934%		
NEMA DESIGN	B		
NUMBER OF STARTS (Hot / Cold)	2 Hot / 3 Cold		
MAX. AMBIENT TEMPERATURE	40° C		
MAX. ELEVATION	3300 Ft. Above Sea Level		
TEMPERATURE RISE (At Full Load)	80° C		
DE BEARING	6309Z		
ODE BEARING	6307Z		
GREASE TYPE	Multemp SRL		
MOUNTING	F1		
ROTATION	Bi-Directional		
APPROXIMATE WEIGHT	270 Lbs..		
AREA CLASSIFICATION	Non-Hazardous		
INVERTER RATING	10:1 CT / 20:1 VT PWM Type		
SPECIFICATION - In Accordance With	NEMA, UR		



WORLDWIDE ELECTRIC MOTOR DRAWING

OCCP-256JM

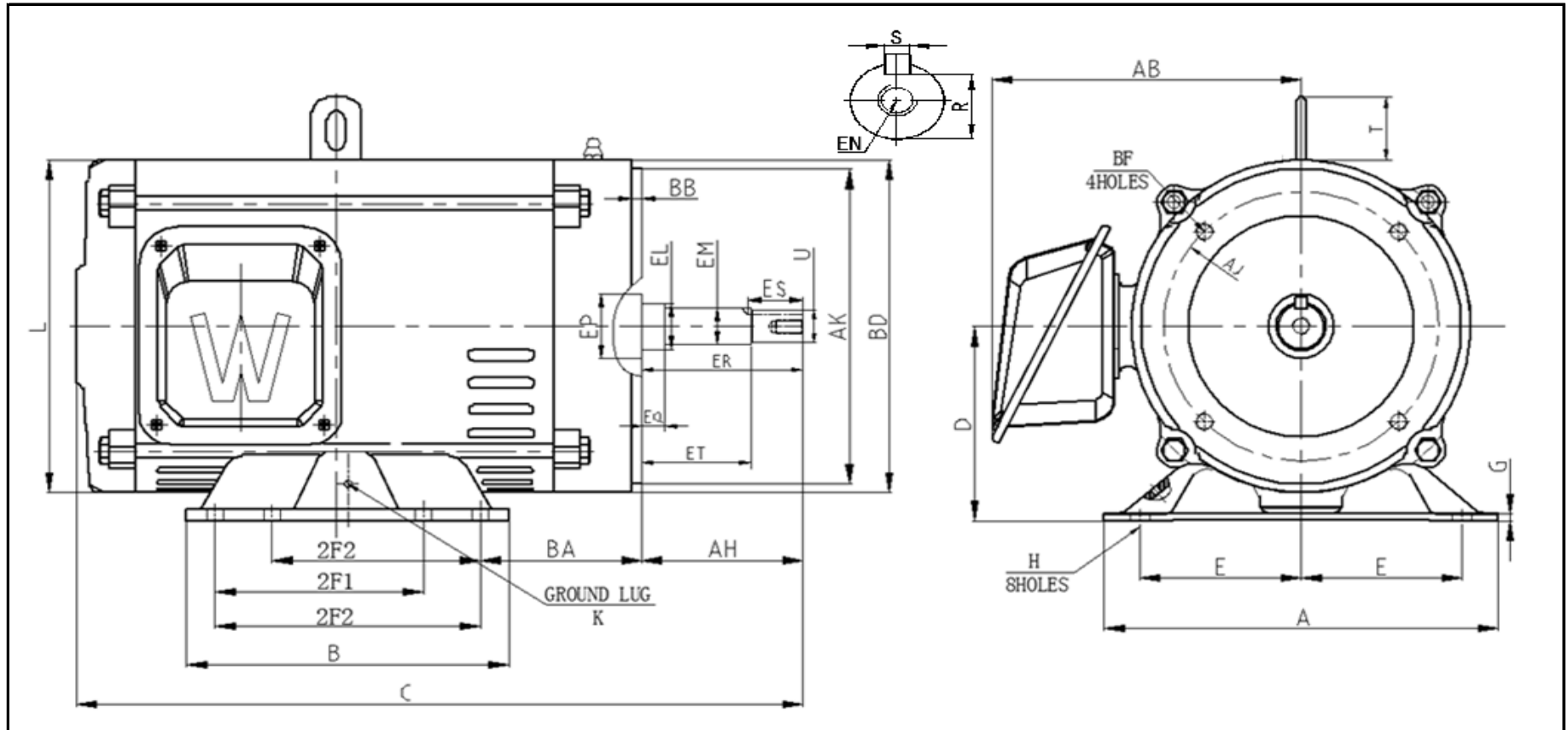

DIMENSIONS - INCHES

MOUNTING					A	B	C	D	G	AB	L	T	KEYSET	KEY	
E	2F1	2F2	H	BA									R	ES	S
5	8.25	10	0.53	4.75	12.05	11.57	23.94	6.25	0.47	9.7	10.6	2.48	1.1	2.53	0.25

FLANGE					AH	SHAFT EXTENSION								K
AK	AJ	BF	BB	BD		EL	EM	EP	EQ	ER	ET	EN	U	
8.5	7.25	1/2-13 * 0.75	0.256	10	5.25	1.75	1.375	1.75	0.625	5.25	3	1/2-13 * 1.0	1.25	M6