

DATA SHEET

Premium Efficiency Motor: **ODP30-36-284TS,**

60 Hz

WorldWide Electric Corporation

1 (800) 808-2131

Worldwideelectric.net



Document Generated: 8-Dec-2023
Document ID:

Customer:

MOTOR INFORMATION	
HP	30
RPM	3600
Phase	3
Frequency	60
Voltage	230/460
Frame Size	284/6TS
Enclosure	ODP
Degree of Protection	IP23
Service Factor	1.15
Poles	2
Full Load Speed	3558
Insulation Class	F
Temp Rise	80°C
NEMA Code Letter	G
Duty Cycle	S1 / Continuous
Slip	1.17%
NEMA Design	B
Moment of Inertia	2.35 lb.ft.^2
Locked Rotor Time (Hot)	12 seconds
Sound Pressure Level	78 dB(A)
Number of Starts	2 Cold / 1 Hot
Max Ambient Temperature	40°C
Max Elevation	1000 m.a.s.l (3300 f.a.s.l)
Mounting	F1
Rotation	Bi-Directional
Area of Classification	Safe Area
Inverter Rating	10:1 CT / 20:1 VT
Standard	NEMA MG 1
Approvals	UL, CE

EFFICIENCY/POWER FACTOR		
LOAD	EFF	P. F.
100%	91.7 %	0.9
75%	93.2 %	0.90
50%	93.2 %	0.87

TORQUE		
FULL LOAD	LRT	BDT
43.45 lb.ft.	333 %	397 %

AMPERAGE INFORMATION		
	230V	460V
Full Load Amps	66.4A	33.2A
Locked Rotor Amps	473.8A	236.9A
No Load Current	12.2A	6.1A
Usable at 208V	36.71A	

BEARING INFORMATION	
DE Bearing	6311Z
ODE Bearing	6310Z
Grease Type	Mobil Polyrex EM
DE Regreasing Interval	2400 Hours
ODE Regreasing Interval	3600 Hours
Grease Quantity	17g/15g

ADDITIONAL DATA	
F2 Suitable	Yes
Shaft Material	AISI 1045
Connection Diagram	12 Lead Delta
Approximate Weight	329 lbs.

MOTOR DRAWING

Premium Efficiency Motor: **ODP30-36-284TS**

WorldWide Electric Corporation

1 (800) 808-2131

Worldwideelectric.net

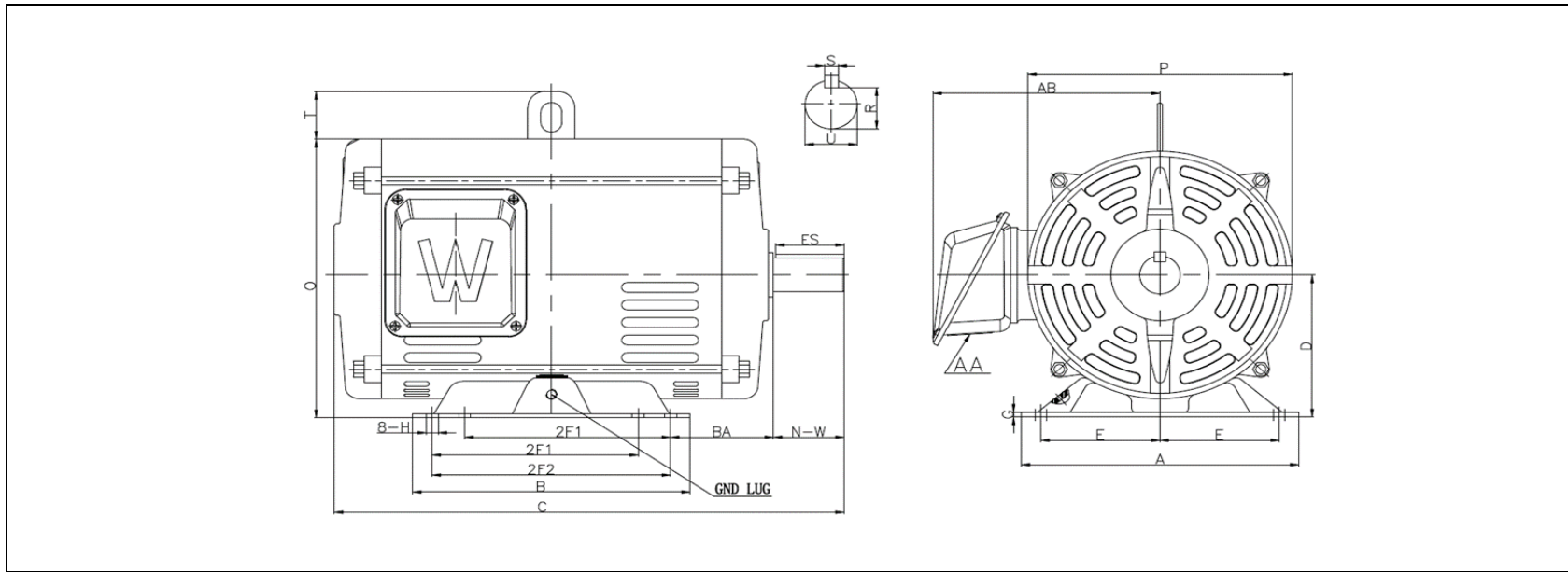

DIMENSION - INCHES

MOUNTING					A	B	C	D	G	P	O	T	AB
E	2F1	2F2	H	BA									
5.5	9.5	11	0.53	4.75	12.8	12.8	22.6	7	0.24	12.2	13.1	2.36	11.1

SHAFT & KEY				
S	ES	R	N-W	U
0.375	1.91	1.416	3.25	1.625

T-BOX	GND LUG
AA	LUG
2	M6*P1.0

PERFORMANCE CURVES

Premium Efficiency Motor:

ODP30-36-284TS

WorldWide Electric Corporation

1 (800) 808-2131

Worldwideelectric.net



Document Generated: 8-Dec-2023
Document ID:

Customer:

Motor Type	ODP		FL Speed	3558	
Output Rating (HP)	30		LRT (%FLT)	333	
Full Load Torque	43.45	lb.ft	460 volt FLA	33.2	
Rotor Wk ²	0.917	lb-ft ²	230 volt FLA	66.4	
			BDT (%FLT)	397	

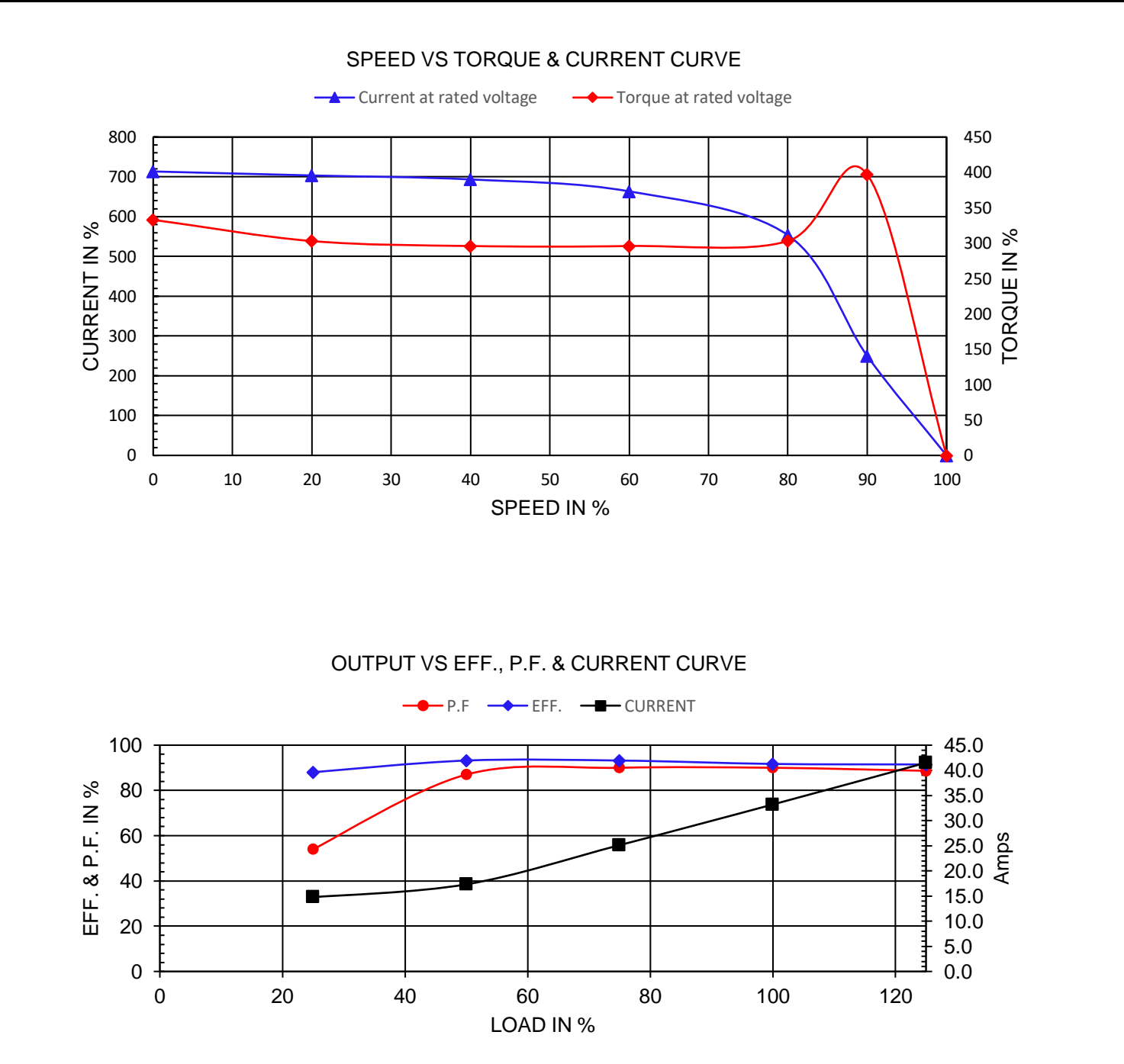

NAMEPLATE / WIRING

WorldWide Electric Corporation

1 (800) 808-2131

Worldwideelectric.net



Premium Efficiency Motor: **ODP30-36-284TS**

Document Generated: 8-Dec-2023
Document ID:

Customer:

SAMPLE NAMEPLATE DATA

		OPEN DRIP PROOF 3 PHASE MOTOR						
Model :		Encl : ODP		SN :				
HP :	Poles :	FR :	Ins : F	IP 23	Max Amb 40°C	Duty:Cont		
Hz : 60	CODE:		Hz : 50	Design : B		L1 L2 L3 230 V		
Volts : 230/460	P.F. :		Volts : 190/380	DE BRG :				
Amps :	Eff: %		Amps :	ODE BRG :				
RPM :	S.F. : 1.15		RPM :	WT: LBS				
WorldWide Electric Corporation							460 V	

Model: ODP30-36-284TS		Encl: ODP					
HP: 30	Poles: 2	Frame 284/6TS	Ins Cl: F	IP IP23			
Hz: 60	Code: G	Hz: 50	Design: B				
Volts: 230/460	P.F.: 0.9	Volts: 190/380	DE Brg: 6311Z				
Amps: 66.4/33.2	Eff: 91.7%	Amps: 79.6/39.8	ODE Brg: 6310Z				
RPM: 3558	S.F.: 1.15	RPM: 2922	WT: 329 lbs.				
		S.F.: 1.0					