

DATA SHEET

Premium Efficiency Motor: **PEWWE20-18-575-256T**

60 Hz

WorldWide Electric Corporation

1 (800) 808-2131

Worldwideelectric.net



Document Generated: 15-Feb-2023
Document ID:

Customer:

MOTOR INFORMATION	
HP	20
RPM	1800
Phase	3
Frequency	60 Hz
Voltage	575 V
Frame Size	256T
Enclosure	TEFC
Degree of Protection	IP55
Service Factor	1.25
Poles	4
Full Load Speed	1765
Insulation Class	F
Temp Rise	80°C
NEMA Code Letter	G
Duty Cycle	S1 / Continuous
Slip	1.94%
NEMA Design	B
Moment of Inertia	2.32 lb.ft.^2
Locked Rotor Time (Hot)	22 seconds
Sound Pressure Level	68 dB(A)
Number of Starts	2 Cold/ 1 Hot
Max Ambient Temperature	40°C
Max Elevation	1000 m.a.s.l (3300 f.a.s.l)
Mounting	F1
Rotation	Bi-Directional
Area of Classification	Class I, Division 2, Groups A, B, C, D
Inverter Rating	10:1 CT / 20:1 VT PWM Type
Standard	NEMA MG-1
Approvals	CSA-US, CE

EFFICIENCY/POWER FACTOR		
LOAD	EFF	P. F.
100%	93.0 %	0.85
75%	93.2 %	0.82
50%	92.9 %	0.72

TORQUE		
FULL LOAD	LRT	BDT
59.5 lb.ft.	180 %	250 %

AMPERAGE INFORMATION		
	575V	
Full Load Amps	19A	
Locked Rotor Amps	116A	
No Load Current	7.5A	

BEARING INFORMATION	
DE Bearing	6309 C3
ODE Bearing	6209 C3
Grease Type	SKF LGHP 2
DE Regreasing Interval	5000 Hours
ODE Regreasing Interval	5000 Hours

ADDITIONAL DATA	
F2 Suitable	Yes
Shaft Material	1045 Carbon Steel
Connection Diagram	575V - 3 Lead Y
Approximate Weight	297 lbs.

MOTOR DRAWING

Premium Efficiency Motor: **PEWWE20-18-575-256T**

WorldWide Electric Corporation

1 (800) 808-2131

Worldwideelectric.net

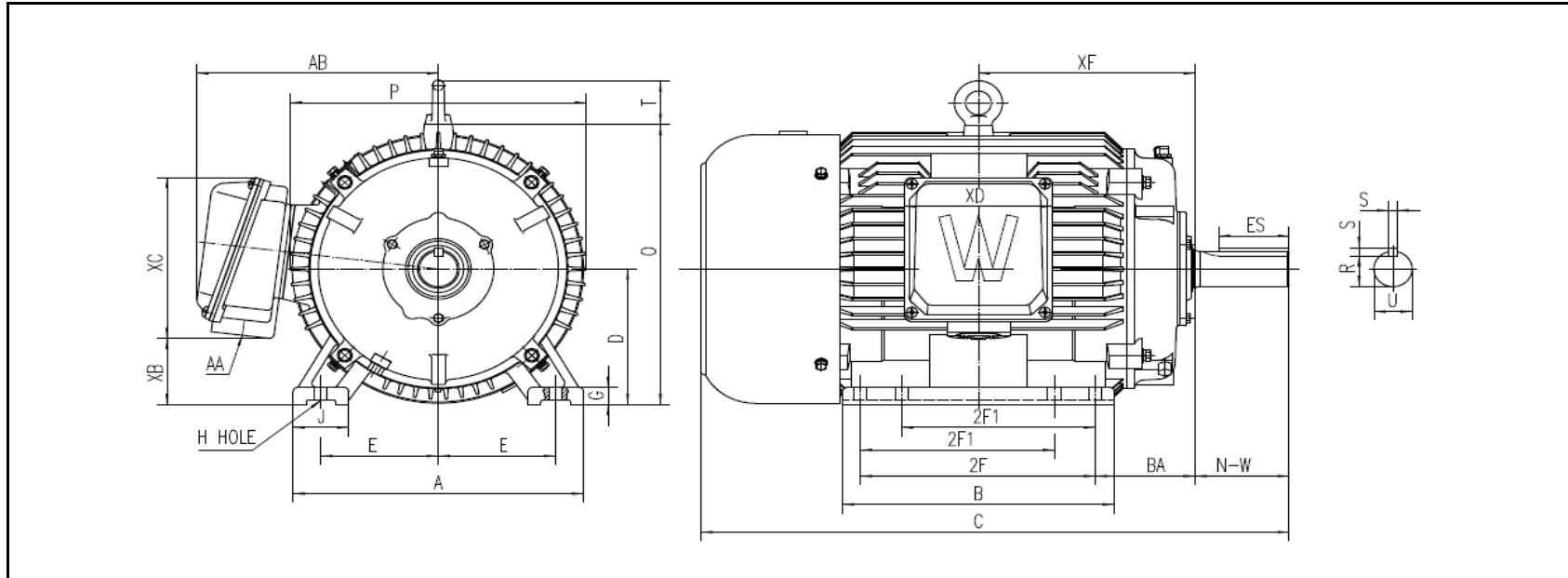

DIMENSION - INCHES

MOUNTING					A	B	C	D	G	J	P	O	T	AB
E	2F1	2F	H	BA										
5	8.25	10	0.53	4.25	12.362	11.575	25.041	6.25	0.787	2.362	12.598	12.894	2.006	10.276

SHAFT & KEY				
S	ES	R	N-W	U
0.375	2.91	1.416	4	1.625

TERMINAL BOX				
AA	XB	XC	XD	XF
1.5	3.047	7.406	6.299	9.23

PERFORMANCE CURVES

WorldWide Electric Corporation

1 (800) 808-2131

Worldwideelectric.net



Premium Efficiency Motor:

PEWWE20-18-575-256T

Document Generated: 15-Feb-2023
Document ID:

Customer:

Motor Type	PEWWE		
Output Rating (HP)	20	FL Speed	1765
Full Load Torque	165 lb.ft	LRT (%FLT)	180
Rotor Wk ²	1.94 lb-ft ²	BDT (%FLT)	250
		575 Volt FLA	19A

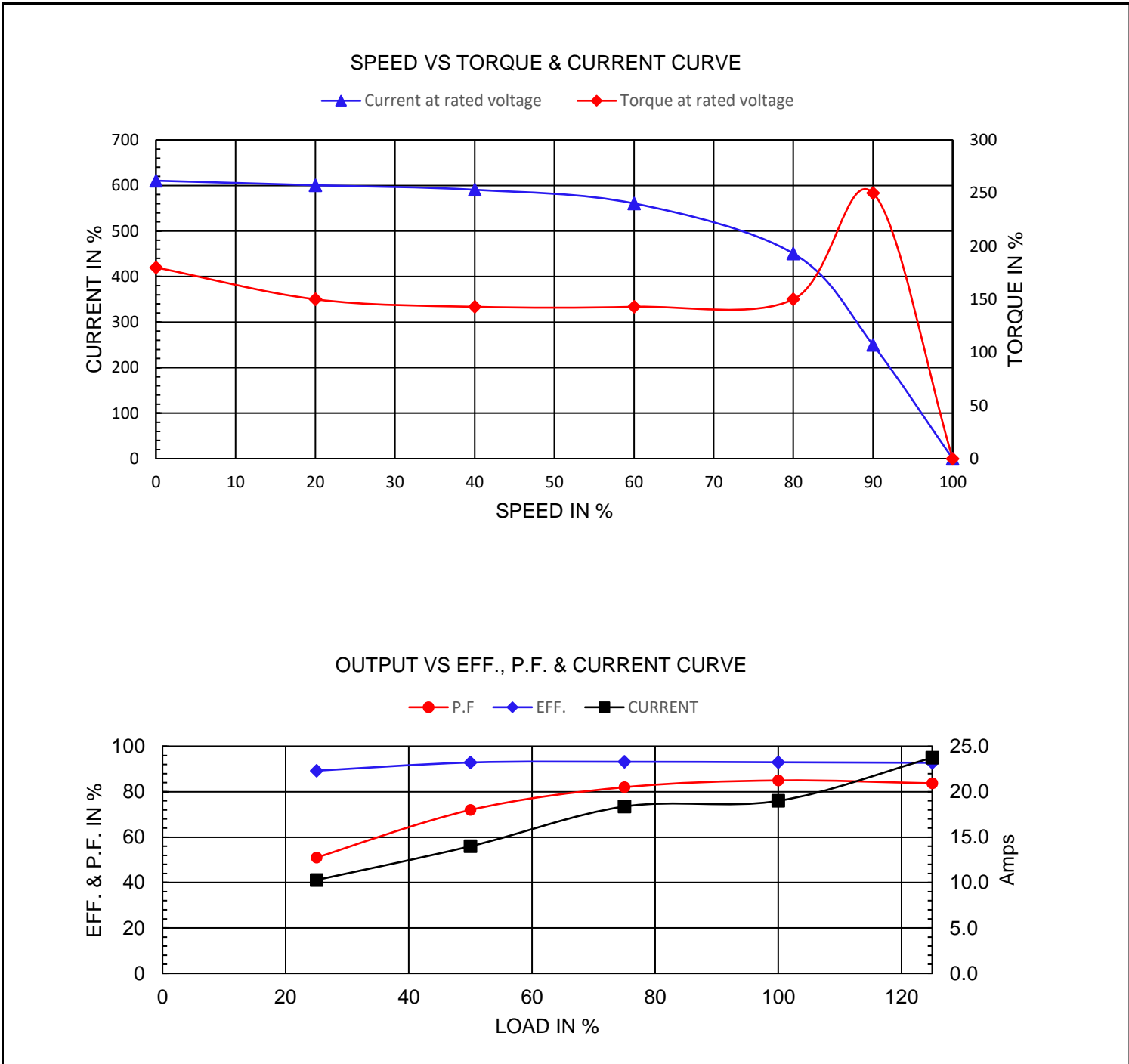

NAMEPLATE / WIRING

WorldWide Electric Corporation

1 (800) 808-2131

Worldwideelectric.net



Premium Efficiency Motor: **PEWWE20-18-575-256T**

Document Generated: 15-Feb-2023
Document ID:

Customer:

SAMPLE NAMEPLATE DATA

		NEMA Premium		3-PHASE INDUCTION MOTOR		259277 	CE CC006A
Model				Ser No.			
HP		S.F.		IP		Encl	
Frame		P.F.		Code		Type	
Voltage		Hz		Ins Cl		Rating	°C Amb Cont
Amps		RPM		Design		Date	
Nom.Eff.	FL	% 3/4	%	V	10:1 CT	20:1 VT	PWM VFD 1.0SF
Class I DIV. 2 Groups A B C D		Amb.40°C	T3C(160°C)	DE Brng			
Class I Zone 2 IIC		Amb.55°C	T3A(180°C)	ODE Brng			
				Grease type:			
50Hz		HP	V	A	rpm	S.F1.0	
WorldWide Electric Corporation							

Model	PEWWE20-18-575-256T						
HP	20	S.F.	1.25	IP	IP55	Encl	TEFC
Frame	256T	P.F.	0.85	Code	G	Amb.	40°C
Voltage	575 V	Hz	60 Hz	Ins Cl	F	DE Brng	6309 C3
Amps	19A	RPM	1765	Design	B	ODE Brng	6209 C3
Nom. Eff.	FL	93.0%	3/4	93.2%			

50Hz 20 HP 500 V 22.4 A 1460 RPM