

DATA SHEET

Premium Efficiency Motor: **PEWWE3-9-215T**

60 Hz

WorldWide Electric Corporation

1 (800) 808-2131

Worldwideelectric.net



Document Generated: 31-Jul-2023

Document ID:

Customer:

MOTOR INFORMATION

HP	3
RPM	900
Phase	3
Frequency	60 Hz
Voltage	230/460 V
Frame Size	215T
Enclosure	TEFC
Degree of Protection	IP55
Service Factor	1.25
Poles	8
Full Load Speed	870
Insulation Class	F
Temp Rise	80°C
NEMA Code Letter	K
Duty Cycle	S1 / Continuous
Slip	3.33%
NEMA Design	B
Moment of Inertia	0.815 lb.ft. ²
Locked Rotor Time (Hot)	15 seconds
Sound Pressure Level	62 dB(A)
Number of Starts	2 Cold/ 1 Hot
Max Ambient Temperature	40°C
Max Elevation	1000 m.a.s.l (3300 f.a.s.l)
Mounting	F1
Rotation	Bi-Directional
Area of Classification	Class 1 Division 2 Groups A,B,C,D T3C(160°C)
Inverter Rating	10:1 CT / 20:1 VT PWM Type
Standard	NEMA MG-1
Approvals	CSA-US, CE

EFFICIENCY/POWER FACTOR

LOAD	EFF	P. F.
100%	85.5 %	0.68
75%	85.4 %	0.58
50%	83.0 %	0.45

TORQUE

FULL LOAD	LRT	BDT
18.1 lb.ft.	210 %	280 %

AMPERAGE INFORMATION

	230V	460V
Full Load Amps	9.66A	4.83A
Locked Rotor Amps	64A	32A
No Load Current	6.9A	3.45A
Usable at 208V	10.7A	

BEARING INFORMATION

DE Bearing	6308ZZ C3
ODE Bearing	6207ZZ C3
Grease Type	-
DE Regreasing Interval	- Hours
ODE Regreasing Interval	- Hours

ADDITIONAL DATA

F2 Suitable	Yes
Shaft Material	1045 Carbon Steel
Connection Diagram	230 / 460 V - 9 Lead Y
Approximate Weight	154 lbs.

MOTOR DRAWING

Premium Efficiency Motor: **PEWWE3-9-215T**

WorldWide Electric Corporation

1 (800) 808-2131

Worldwideelectric.net

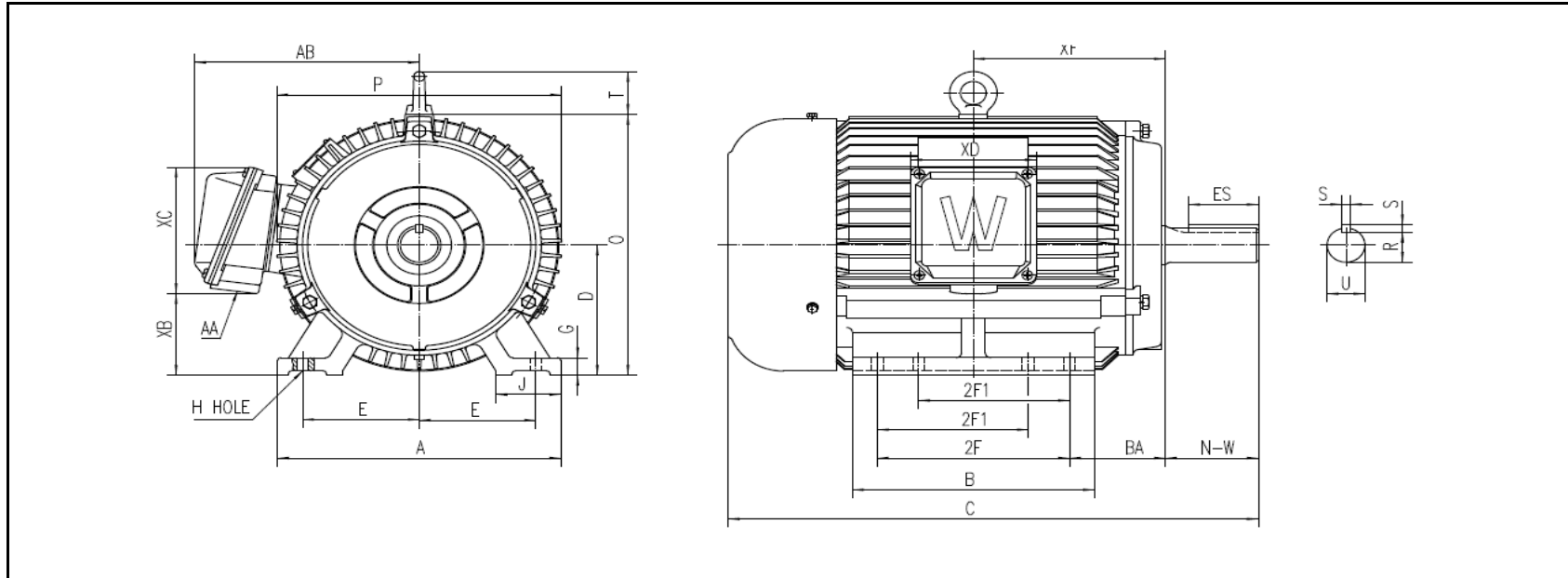

DIMENSION - INCHES

MOUNTING					A	B	C	D	G	J	P	O	T	AB
E	2F1	2F	H	BA										
4.25	5.5	7	0.41	3.5	10.315	8.819	19.319	5.25	0.709	2.362	10.389	10.526	1.732	8.178

SHAFT & KEY				
S	ES	R	N-W	U
0.312	2.41	1.201	3.38	1.375

TERMINAL BOX				
AA	XB	XC	XD	XF
1	3.296	5.098	4.567	7.002

PERFORMANCE CURVES

WorldWide Electric Corporation

1 (800) 808-2131

Worldwideelectric.net



Premium Efficiency Motor:

PEWWE3-9-215T

Document Generated: 31-Jul-2023
 Document ID:

Customer:

Motor Type	PEWWE		FL Speed	870	
Output Rating (HP)	3		LRT (%FLT)	210	460 volt FLA 4.83 A
Full Load Torque	18.1	lb.ft	BDT (%FLT)	280	230 volt FLA 9.66 A
Rotor Wk ²	0.815	lb-ft ²			

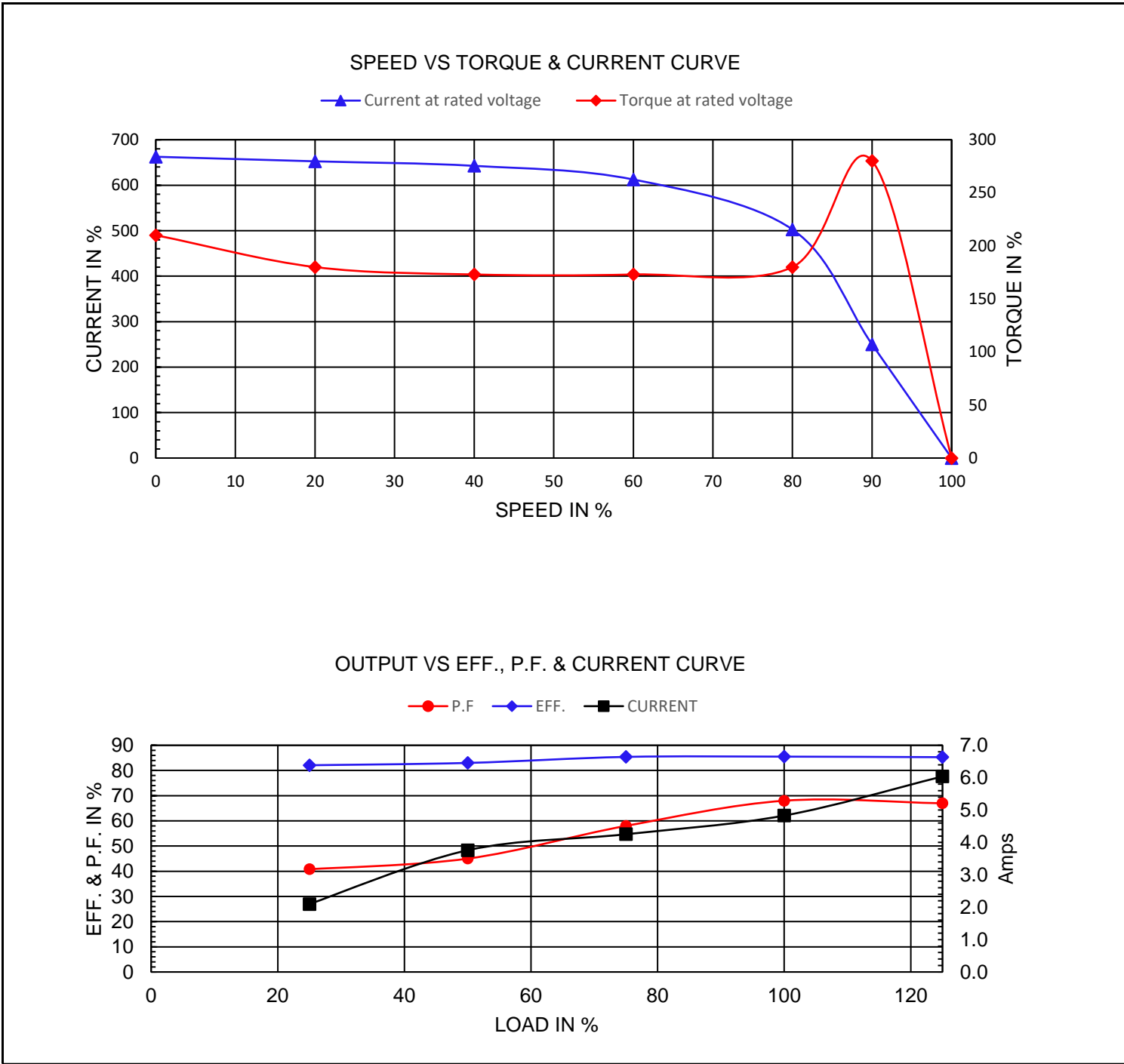

NAMEPLATE / WIRING

WorldWide Electric Corporation

1 (800) 808-2131

Worldwideelectric.net



Premium Efficiency Motor:

PEWWE3-9-215T

Document Generated: 31-Jul-2023
Document ID:

Customer:

SAMPLE NAMEPLATE DATA

		NEMA Premium		3-PHASE INDUCTION MOTOR		259277 		CC006A
Model			Ser No.			Low Voltage		
HP		S.F.		IP		Encl		
Frame		P.F.		Code		Type		
Voltage	230/460	Hz		Ins Cl		Rating	°C Amb Cont	
Amps		RPM		Design		Date		
Nom. Eff.	FL	% 3/4		% 230/460V		10:1 CT 20:1 VT PWM VFD	1.0SF	
Class I DIV. 2 Groups A B C D				Amb.40°C	T3C(160°C)	DE Brng		
Class I Zone 2 IIC				Amb.55°C	T3A(180°C)	ODE Brng		
						Grease type:		
50Hz		HP	V	A	rpm	S.F1.0		

Model	PEWWE3-9-215T							
HP	3	S.F.	1.25	IP	IP55	Encl	TEFC	
Frame	215T	P.F.	0.68	Code	K	Type		
Voltage	230/460 V	Hz	60 Hz	Ins Cl	F	Ambient	40°C	
Amps	9.66/4.83	RPM	870	Design	B	DE Brng 6308ZZ C3		
Nom. Eff.	FL	85.5%	3/4	85.4%	ODE Brng 6207ZZ C3			
Class 1 Division 2 Groups A,B,C,D					T3C(160°C)	Grease type: -		
50Hz	3 HP	200/400 V	12.2/6.12 A	715 rpm				