

DATA SHEET

Premium Efficiency Motor: **PEWWE350-18-449TBB-IB**

60 Hz

WorldWide Electric Corporation

1 (800) 808-2131

Worldwideelectric.net



Document Generated: 31-Jul-2023
Document ID:

Customer:

MOTOR INFORMATION	
HP	350
RPM	1800
Phase	3
Frequency	60 Hz
Voltage	460 V
Frame Size	449T
Enclosure	TEFC
Degree of Protection	IP55
Service Factor	1.15
Poles	4
Full Load Speed	1790
Insulation Class	F
Temp Rise	80°C
NEMA Code Letter	G
Duty Cycle	S1 / Continuous
Slip	0.56%
NEMA Design	B
Moment of Inertia	93.9 lb.ft.^2
Locked Rotor Time (Hot)	14 seconds
Sound Pressure Level	85 dB(A)
Number of Starts	2 Cold/ 1 Hot
Max Ambient Temperature	40°C
Max Elevation	1000 m.a.s.l (3300 f.a.s.l)
Mounting	F1
Rotation	Bi-Directional
Area of Classification	Class 1 Division 2 Groups A,B,C,D T3(200°C)
Inverter Rating	10:1 CT / 20:1 VT PWM Type
Standard	NEMA MG-1
Approvals	CSA-US, CE

EFFICIENCY/POWER FACTOR		
LOAD	EFF	P. F.
100%	96.2 %	0.87
75%	96.3 %	0.85
50%	96.0 %	0.77

TORQUE		
FULL LOAD	LRT	BDT
1027 lb.ft.	190 %	250 %

AMPERAGE INFORMATION		
	230V	460V
Full Load Amps	--A	392A
Locked Rotor Amps	--A	2550A
No Load Current	--A	125A
Usable at 208V	--A	

BEARING INFORMATION	
DE Bearing	6322 C3
ODE Bearing	6320 M/C3
Grease Type	SKF LGHP 2
DE Regreasing Interval	1300 Hours
ODE Regreasing Interval	1800 Hours

ADDITIONAL DATA	
F2 Suitable	Yes
Shaft Material	4140 Carbon Steel
Connection Diagram	460 V - 6 Lead Δ
Approximate Weight	2870 lbs.

MOTOR DRAWING

Premium Efficiency Motor: **PEWWE350-18-449TBB-IB**

WorldWide Electric Corporation

1 (800) 808-2131

Worldwideelectric.net

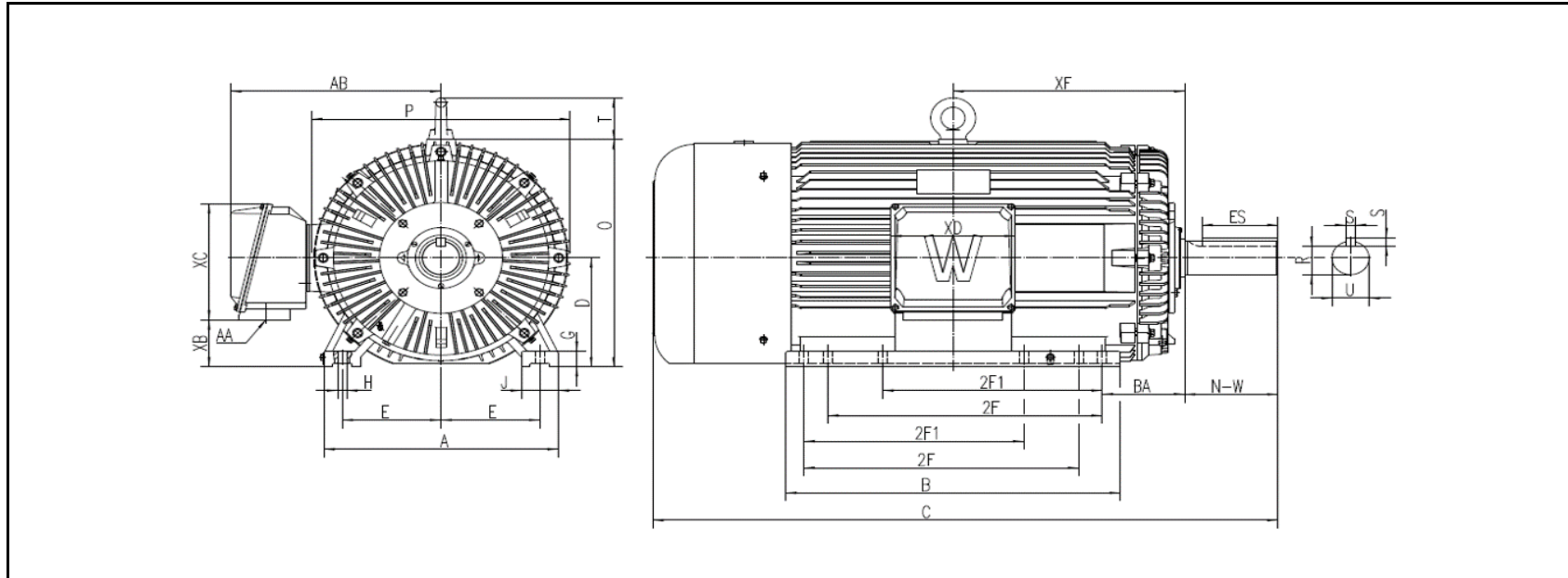

DIMENSION - INCHES

MOUNTING					A	B	C	D	G	J	P	O	T	AB
E	2F1	2F	H	BA										
9	20	25	0.81	7.5	21.339	30.472	56.945	11	1.575	3.346	23.554	22.969	4.213	19.171

SHAFT & KEY				
S	ES	R	N-W	U
0.875	6.91	2.88	8.5	3.375

TERMINAL BOX				
AA	XB	XC	XD	XF
2 X 3	4.7	11.813	11.339	21.087

PERFORMANCE CURVES

WorldWide Electric Corporation

1 (800) 808-2131

Worldwideelectric.net



Premium Efficiency Motor:

PEWWE350-18-449TBB-IB

Document Generated: 31-Jul-2023
 Document ID:

Customer:

Motor Type	PEWWE		FL Speed	1790	
Output Rating (HP)	350		LRT (%FLT)	190	460 volt FLA 392 A
Full Load Torque	1027	lb.ft	BDT (%FLT)	250	230 volt FLA -- A
Rotor Wk^2	93.9	lb-ft^2			

SPEED VS TORQUE & CURRENT CURVE

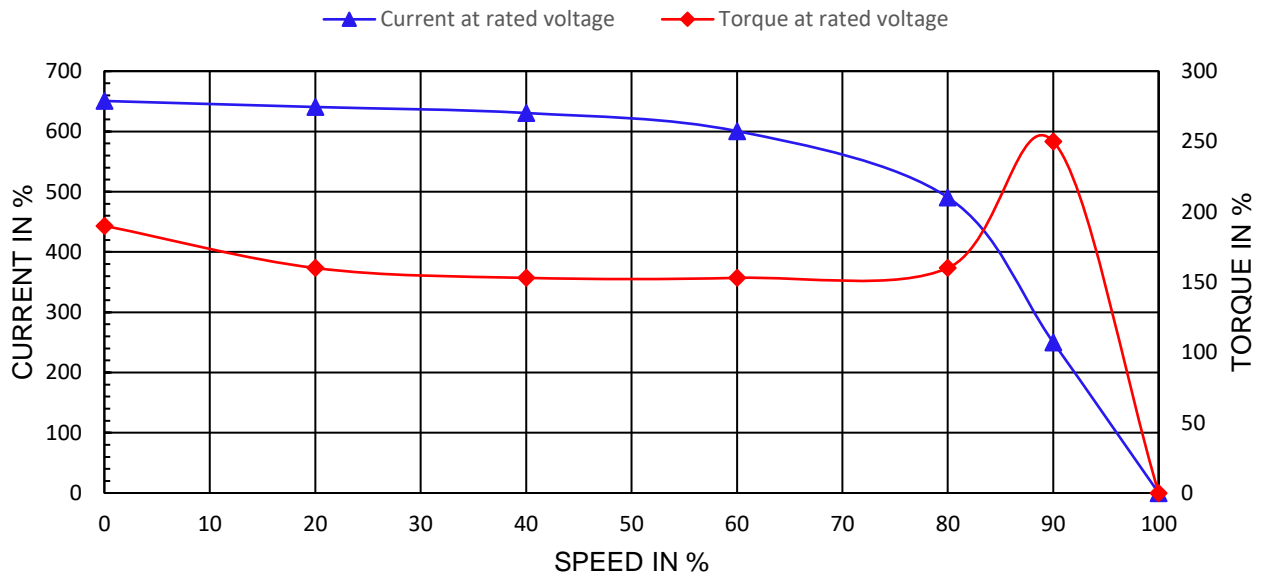

OUTPUT VS EFF., P.F. & CURRENT CURVE

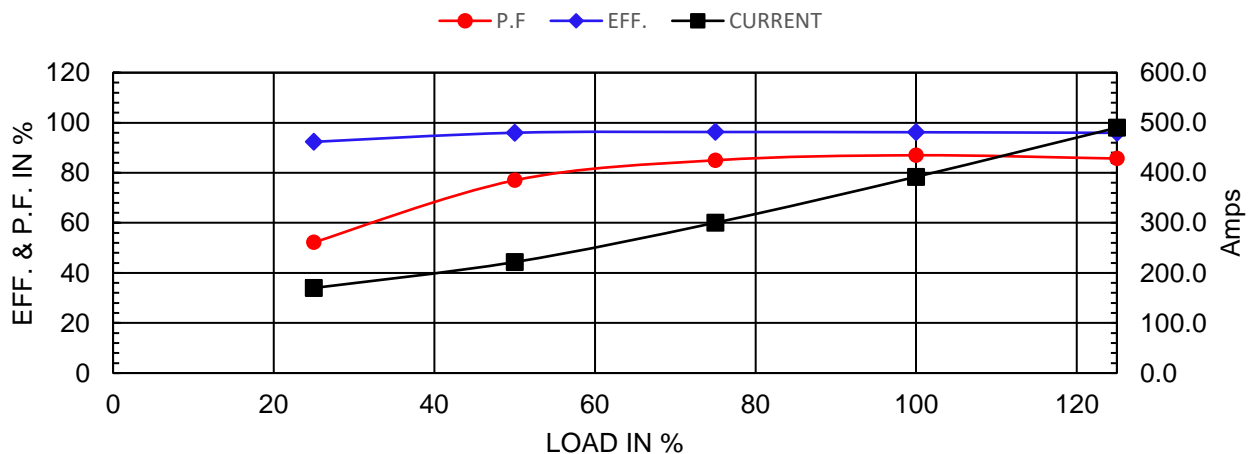

NAMEPLATE / WIRING

WorldWide Electric Corporation

1 (800) 808-2131

Worldwideelectric.net



Premium Efficiency Motor:

PEWWE350-18-449TBB-IB

Document Generated: 31-Jul-2023
Document ID:

Customer:

SAMPLE NAMEPLATE DATA

		NEMA Premium		3-PHASE INDUCTION MOTOR		259277		
Model	<input type="text"/>	Ser No.	<input type="text"/>	Connection				
HP	<input type="text"/>	S.F.	<input type="text"/>	IP	<input type="text"/>	Encl	<input type="text"/>	
Frame	<input type="text"/>	P.F.	<input type="text"/>	Code	<input type="text"/>	Type	<input type="text"/>	
Voltage	<input type="text"/>	Hz	<input type="text"/>	Ins Cl	<input type="text"/>	Rating	<input type="text"/>	
Amps	<input type="text"/>	RPM	<input type="text"/>	Design	<input type="text"/>	Date	<input type="text"/>	
Nom.Eff.	FL	% 3/4	%	V	10:1 CT	20:1 VT	PWM	VFD 1.0SF
Class I DIV. 2 Groups A B C D				Amb.40°C				
DE Brng				Grease type: LGHP 2				
ODE Brng				(compatible with polyrex)				
WorldWide Electric Corporation								

Model	<input type="text" value="PEWWE350-18-449TBB-IB"/>								
HP	<input type="text" value="350"/>	S.F.	<input type="text" value="1.15"/>	IP	<input type="text" value="IP55"/>	Encl	<input type="text" value="TEFC"/>		
Frame	<input type="text" value="449T"/>	P.F.	<input type="text" value="0.87"/>	Code	<input type="text" value="G"/>	Type			
Voltage	<input type="text" value="460 V"/>	Hz	<input type="text" value="60 Hz"/>	Ins Cl	<input type="text" value="F"/>	Ambient	<input type="text" value="40°C"/>		
Amps	<input type="text" value="392"/>	RPM	<input type="text" value="1790"/>	Design	<input type="text" value="B"/>	DE Brng 6322 C3			
Nom.Eff.	<input type="text" value="FL 96.2% 3/4 96.3%"/>					ODE Brng 6320 M/C3			
Class 1 Division 2 Groups A,B,C,D						T3(200°C)		Grease type: SKF LGHP 2	
50Hz	--	HP	--	--	A	-- rpm			