

DATA SHEET

Premium Efficiency Motor: **PEWWE350-18-586/7**

60 Hz

WorldWide Electric Corporation

1 (800) 808-2131

Worldwideelectric.net



Document Generated: 31-Jul-2023
Document ID:

Customer:

MOTOR INFORMATION	
HP	350
RPM	1800
Phase	3
Frequency	60 Hz
Voltage	460 V
Frame Size	586/7
Enclosure	TEFC
Degree of Protection	IP55
Service Factor	1.15
Poles	4
Full Load Speed	1790
Insulation Class	F
Temp Rise	80°C
NEMA Code Letter	G
Duty Cycle	S1 / Continuous
Slip	0.56%
NEMA Design	B
Moment of Inertia	157 lb.ft.^2
Locked Rotor Time (Hot)	22 seconds
Sound Pressure Level	86 dB(A)
Number of Starts	2 Cold/ 1 Hot
Max Ambient Temperature	40°C
Max Elevation	1000 m.a.s.l (3300 f.a.s.l)
Mounting	F1
Rotation	Bi-Directional
Area of Classification	Class 1 Division 2 Groups A,B,C,D T3(200°C)
Inverter Rating	10:1 CT / 20:1 VT PWM Type
Standard	NEMA MG-1
Approvals	CSA-US, CE

EFFICIENCY/POWER FACTOR		
LOAD	EFF	P. F.
100%	96.2 %	0.91
75%	96.2 %	0.89
50%	96.0 %	0.85

TORQUE		
FULL LOAD	LRT	BDT
1027 lb.ft.	190 %	250 %

AMPERAGE INFORMATION		
	230V	460V
Full Load Amps	--A	374A
Locked Rotor Amps	--A	2550A
No Load Current	--A	91A
Usable at 208V	--A	

BEARING INFORMATION	
DE Bearing	NU326 C3
ODE Bearing	6324 C3
Grease Type	SKF LGHP 2
DE Regreasing Interval	1000 Hours
ODE Regreasing Interval	1500 Hours

ADDITIONAL DATA	
F2 Suitable	Yes
Shaft Material	4140 Carbon Steel
Connection Diagram	460 V - 6 Lead Δ
Approximate Weight	4070 lbs.

MOTOR DRAWING

Premium Efficiency Motor: **PEWWE350-18-586/7**

WorldWide Electric Corporation

1 (800) 808-2131

Worldwideelectric.net

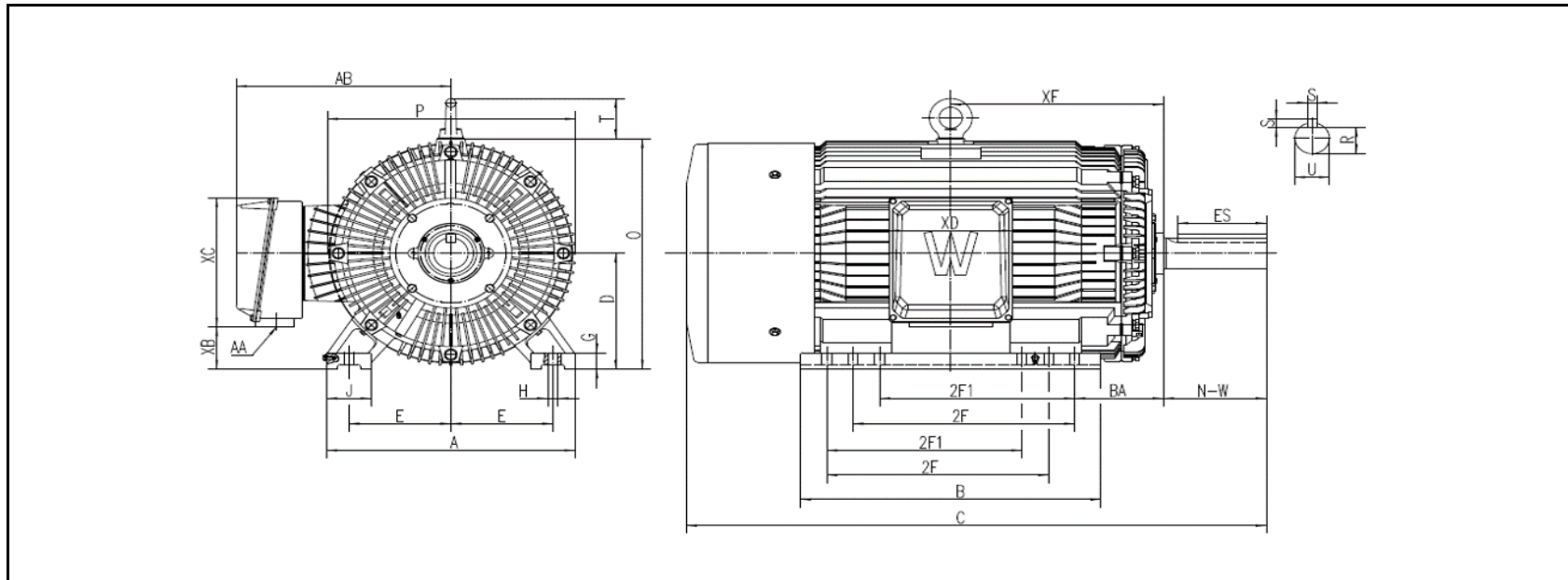

DIMENSION - INCHES

MOUNTING					A	B	C	D	G	J	P	O	T	AB
E	2F1	2F	H	BA										
11.5	22	25	1.125	10	27.992	33.858	66.231	14.5	2.047	5	28.011	28.87	5.02	24.212

SHAFT & KEY				
S	ES	R	N-W	U
1	10	3.309	11.625	3.875

TERMINAL BOX				
AA	XB	XC	XD	XF
2 X 3	5.287	16.158	13.937	23.976

PERFORMANCE CURVES

WorldWide Electric Corporation

1 (800) 808-2131

Worldwideelectric.net



Premium Efficiency Motor:

PEWWE350-18-586/7

Document Generated: 31-Jul-2023
 Document ID:

Customer:

Motor Type	PEWWE		FL Speed	1790	
Output Rating (HP)	350		LRT (%FLT)	190	460 volt FLA 374 A
Full Load Torque	1027	lb.ft	BDT (%FLT)	250	230 volt FLA -- A
Rotor Wk^2	157	lb-ft^2			

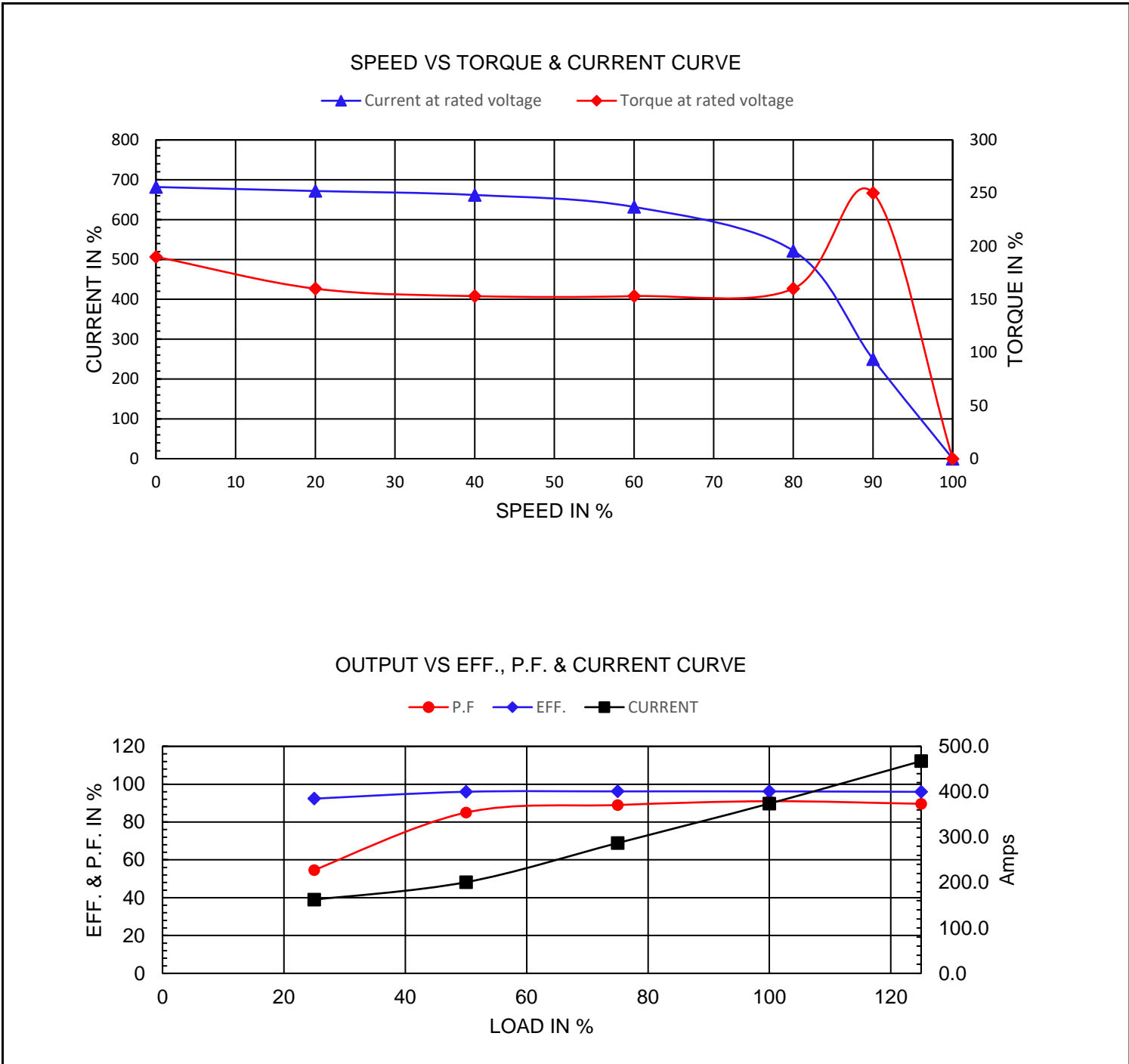

NAMEPLATE / WIRING

WorldWide Electric Corporation

1 (800) 808-2131

Worldwideelectric.net



Premium Efficiency Motor:

PEWWE350-18-586/7

Document Generated: 31-Jul-2023
Document ID:

Customer:

SAMPLE NAMEPLATE DATA

		NEMA Premium		3-PHASE INDUCTION MOTOR		259277		
Model	<input type="text"/>	Ser No.	<input type="text"/>	Connection				
HP	<input type="text"/>	S.F.	<input type="text"/>	IP	<input type="text"/>	Encl	<input type="text"/>	
Frame	<input type="text"/>	P.F.	<input type="text"/>	Code	<input type="text"/>	Type	<input type="text"/>	
Voltage	<input type="text"/>	Hz	<input type="text"/>	Ins Cl	<input type="text"/>	Rating	<input type="text"/>	
Amps	<input type="text"/>	RPM	<input type="text"/>	Design	<input type="text"/>	Date	<input type="text"/>	
Nom.Eff.	<input type="text"/>	<input type="text"/>	<input type="text"/>	<input type="text"/>	<input type="text"/>	<input type="text"/>	<input type="text"/>	<input type="text"/>
Class I DIV. 2 Groups A B C D				Amb.40°C				
DE Brng				Grease type: LGHP 2				
ODE Brng				(compatible with polyrex)				
WorldWide Electric Corporation								

Model	<input type="text" value="PEWWE350-18-586/7"/>								
HP	<input type="text" value="350"/>	S.F.	<input type="text" value="1.15"/>	IP	<input type="text" value="IP55"/>	Encl	<input type="text" value="TEFC"/>		
Frame	<input type="text" value="586/7"/>	P.F.	<input type="text" value="0.91"/>	Code	<input type="text" value="G"/>	Type			
Voltage	<input type="text" value="460 V"/>	Hz	<input type="text" value="60 Hz"/>	Ins Cl	<input type="text" value="F"/>	Ambient	<input type="text" value="40°C"/>		
Amps	<input type="text" value="374"/>	RPM	<input type="text" value="1790"/>	Design	<input type="text" value="B"/>	DE Brng NU326 C3			
Nom.Eff.	<input type="text" value="FL 96.2% 3/4 96.2%"/>					ODE Brng 6324 C3			
Class 1 Division 2 Groups A,B,C,D T3(200°C)						Grease type: SKF LGHP 2			
50Hz	--	HP	--	--	A	--	rpm		