

# DATA SHEET

Premium Efficiency Motor: **PEWWE75-9-444T**

**60 Hz**

WorldWide Electric Corporation

1 (800) 808-2131

Worldwideelectric.net



Document Generated: 31-Jul-2023  
Document ID:

Customer:

MOTOR INFORMATION	
HP	75
RPM	900
Phase	3
Frequency	60 Hz
Voltage	230/460 V
Frame Size	444T
Enclosure	TEFC
Degree of Protection	IP55
Service Factor	1.25
Poles	8
Full Load Speed	890
Insulation Class	F
Temp Rise	80°C
NEMA Code Letter	G
Duty Cycle	S1 / Continuous
Slip	1.10%
NEMA Design	B
Moment of Inertia	48.9 lb.ft.^2
Locked Rotor Time (Hot)	14 seconds
Sound Pressure Level	73 dB(A)
Number of Starts	2 Cold/ 1 Hot
Max Ambient Temperature	40°C
Max Elevation	1000 m.a.s.l (3300 f.a.s.l)
Mounting	F1
Rotation	Bi-Directional
Area of Classification	Class 1 Division 2 Groups A,B,C,D T3A(180°C)
Inverter Rating	10:1 CT / 20:1 VT PWM Type
Standard	NEMA MG-1
Approvals	CSA-US, CE

EFFICIENCY/POWER FACTOR		
LOAD	EFF	P. F.
100%	93.6 %	0.74
75%	93.9 %	0.69
50%	93.3 %	0.58

TORQUE		
FULL LOAD	LRT	BDT
442 lb.ft.	140 %	200 %

AMPERAGE INFORMATION		
	230V	460V
Full Load Amps	203A	101A
Locked Rotor Amps	1085A	542.5A
No Load Current	95A	47.5A
Usable at 208V	224A	

BEARING INFORMATION	
DE Bearing	NU318 C3
ODE Bearing	6313 C3
Grease Type	SKF LGHP 2
DE Regreasing Interval	2500 Hours
ODE Regreasing Interval	5100 Hours

ADDITIONAL DATA	
F2 Suitable	Yes
Shaft Material	1045 Carbon Steel
Connection Diagram	230 / 460 V - 12 Lead Δ
Approximate Weight	1316 lbs.

# MOTOR DRAWING

Premium Efficiency Motor: **PEWWE75-9-444T**

WorldWide Electric Corporation

1 (800) 808-2131

Worldwideelectric.net

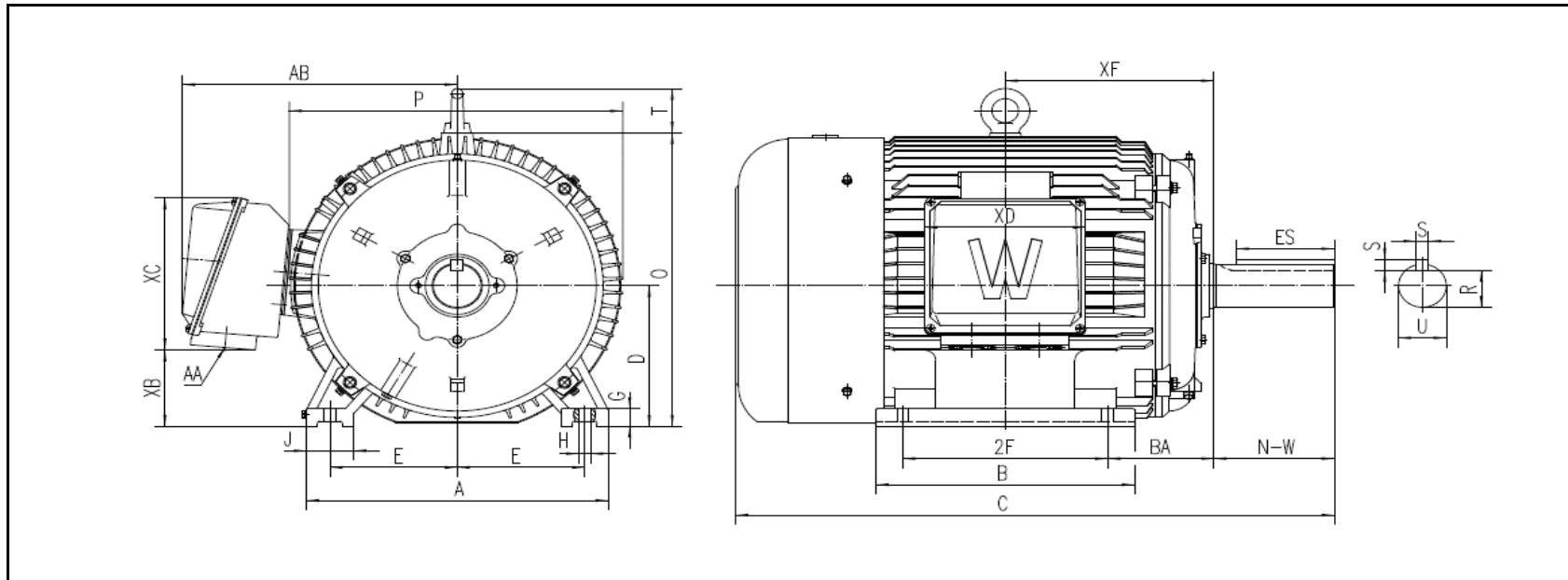

## DIMENSION - INCHES

MOUNTING					A	B	C	D	G	J	P	O	T	AB
E	2F1	2F	H	BA										
9	--	14.5	0.81	7.5	21.339	18.268	42.301	11	1.378	3.346	23.574	22.969	3.465	19.436

SHAFT & KEY				
S	ES	R	N-W	U
0.875	6.91	2.88	8.5	3.375

TERMINAL BOX				
AA	XB	XC	XD	XF
2 X 3	5.97	11.905	11.339	14.744

# PERFORMANCE CURVES

WorldWide Electric Corporation

1 (800) 808-2131

Worldwideelectric.net



Premium Efficiency Motor:

**PEWWE75-9-444T**

Document Generated: 31-Jul-2023  
 Document ID:

Customer:

Motor Type	PEWWE		FL Speed	890	
Output Rating (HP)	75		LRT (%FLT)	140	460 volt FLA 101 A
Full Load Torque	442 lb.ft		BDT (%FLT)	200	230 volt FLA 203 A
Rotor Wk <sup>2</sup>	48.9 lb-ft <sup>2</sup>				

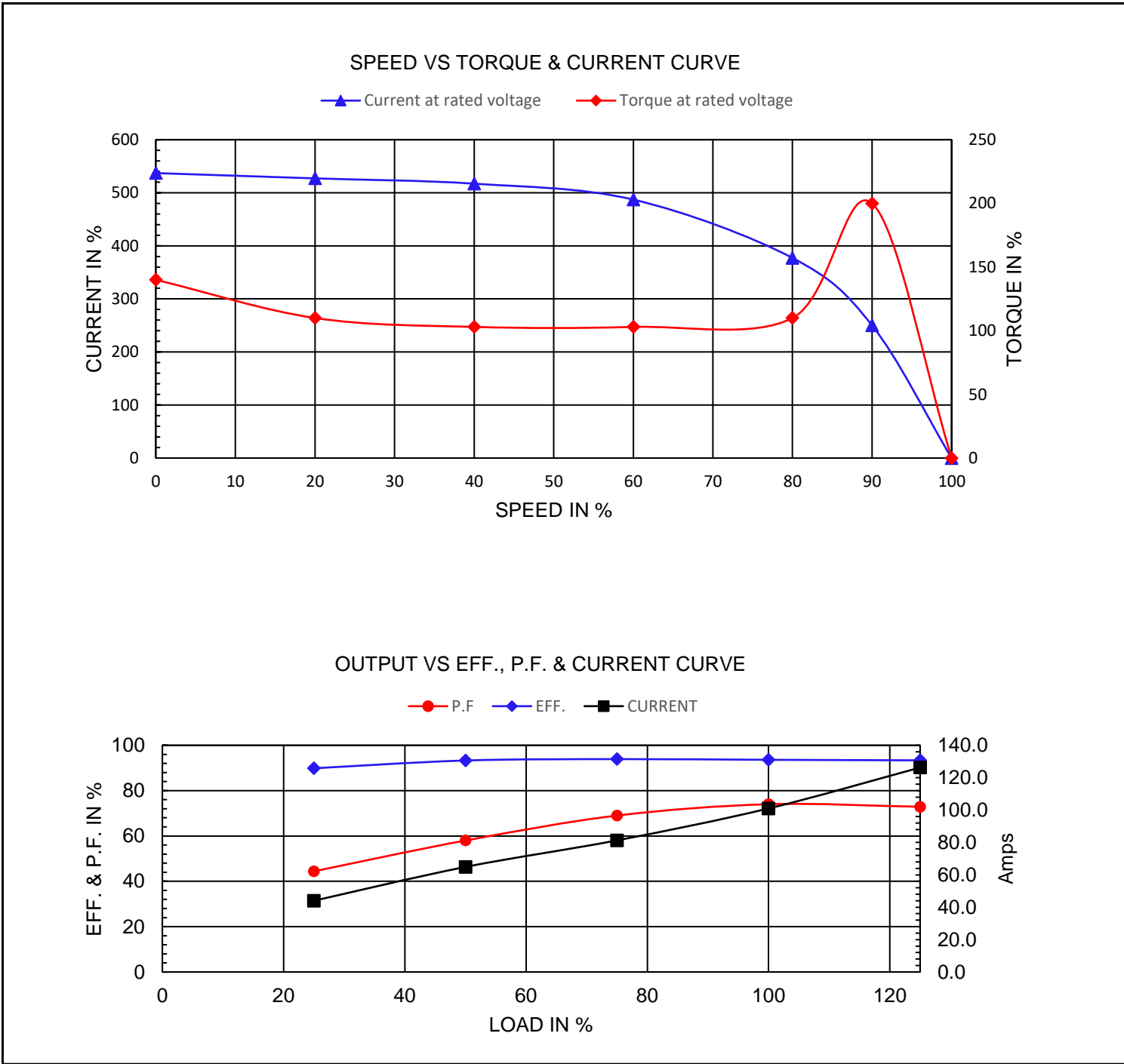

# NAMEPLATE / WIRING

WorldWide Electric Corporation

1 (800) 808-2131

Worldwideelectric.net



Premium Efficiency Motor:

**PEWWE75-9-444T**

Document Generated: 31-Jul-2023  
Document ID:

Customer:

## SAMPLE NAMEPLATE DATA

		<b>NEMA Premium</b>		<b>3-PHASE INDUCTION MOTOR</b>		259277 	<b>CE</b> CC006A
Model		Ser No.					
HP		S.F.		IP		Encl	
Frame		P.F.		Code		Type	
Voltage	230/460	Hz		Ins Cl		Rating	°C Amb Cont
Amps		RPM		Design		Date	
Nom.Eff.	FL	% 3/4	% 230/460V	10:1 CT	20:1 VT	PWM	VFD 1.0SF
Class I DIV. 2 Groups A B C D				Amb.40°C		DE Brng	
Class I Zone 2 IIC				Amb.55°C		ODE Brng	
				Grease type: LGHP 2 (compatible with polyrex)			
50Hz		HP	V	A	rpm	1.0SF	
<b>WorldWide Electric Corporation</b>							

Model

HP  S.F.  IP  Encl

Frame  P.F.  Code  Type

Voltage  Hz  Ins Cl  Ambient

Amps  RPM  Design  DE Brng

Nom.Eff.     ODE Brng

Grease type: