

DATA SHEET

Premium Efficiency Motor: **SSPE5-18-184TC,**

60 Hz

WorldWide Electric Corporation

1 (800) 808-2131

Worldwideelectric.net



Document Generated: 22-Feb-2023
Document ID:

Customer:

MOTOR INFORMATION	
HP	5
RPM	1800
Phase	3
Frequency	60
Voltage	230/460
Frame Size	184TC
Enclosure	TEFC
Degree of Protection	IP69K
Service Factor	1.15
Poles	4
Full Load Speed	1765
Insulation Class	F
Temp Rise	80°C
NEMA Code Letter	J
Duty Cycle	S1
Slip	1.94%
NEMA Design	B
Moment of Inertia	0.5 lb.ft.^2
Locked Rotor Time (Hot)	12 seconds
Sound Pressure Level	64 dB(A)
Number of Starts	12
Max Ambient Temperature	40° C
Max Elevation	1000 m.a.s.l (3300 f.a.s.l)
Mounting	F1
Rotation	Bidirectional
Area of Classification	Div.2 Class I, Gr. A,B,C&D T2B
Inverter Rating	10:1 CT/20:1 VT
Standard	NEMA MG1, UL1004
Approvals	CSA,UL,CE

EFFICIENCY/POWER FACTOR		
LOAD	EFF	P. F.
100%	89.5 %	0.85
75%	90.0 %	0.77
50%	89.0 %	0.66

TORQUE		
FULL LOAD	LRT	BDT
14.7 lb.ft.	225 %	280 %

AMPERAGE INFORMATION		
	230V	460V
Full Load Amps	12.5	6.25
Locked Rotor Amps	92	46
No Load Current	6	3
Usable at 208V		13

BEARING INFORMATION	
DE Bearing	6308 2RS
ODE Bearing	6306 2RS
Grease Type	Mobil Polyrex EM

ADDITIONAL DATA	
F2 Suitable	No
Shaft Material	304 Stainless Steel
Connection Diagram	9 Lead 2Y/Y
Approximate Weight	100 lbs.

MOTOR DRAWING

Premium Efficiency Motor: **SSPE5-18-184TC**

WorldWide Electric Corporation

1 (800) 808-2131

Worldwideelectric.net

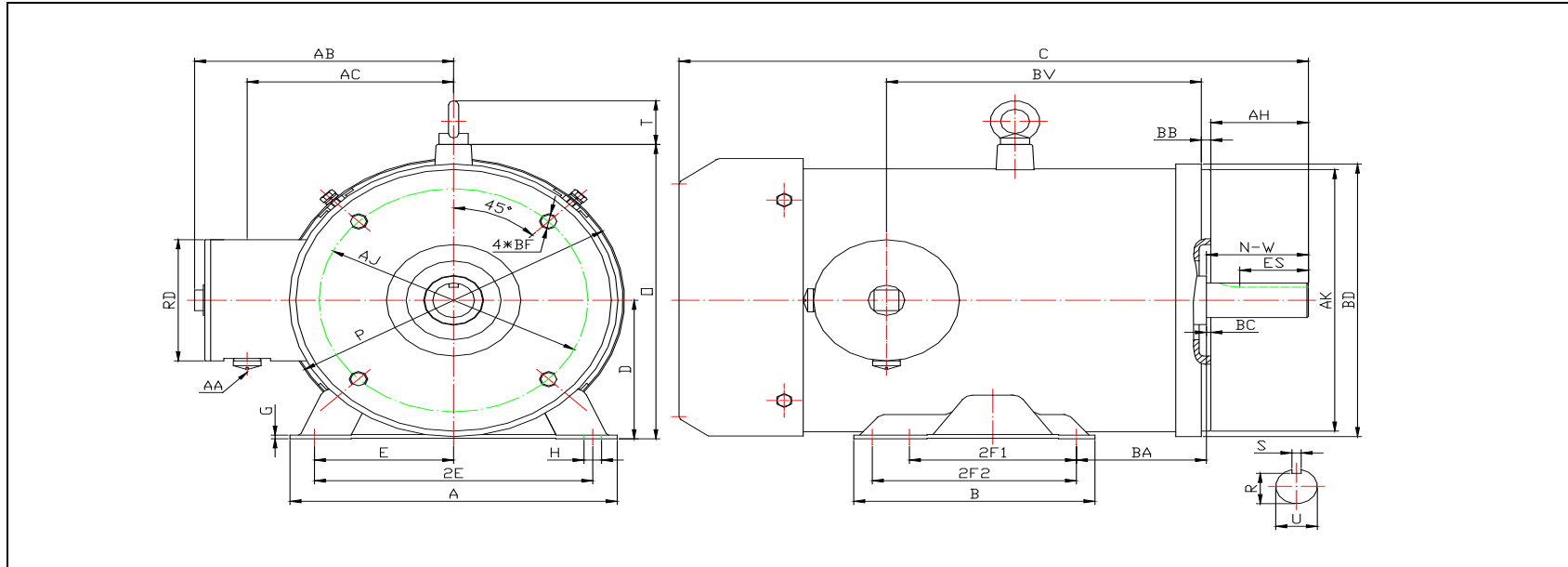

DIMENSION - INCHES

MOUNTING					A	B	C	D	G	P	O	T	AB
E	2F1	2F2	H	BA									
3.75	4.5	5.5	0.71*0.47	3.5	8.8	6.5	17	4.5	0.118	9.25	9.55	1.45	7

SHAFT & KEY					
S	ES	R	N-W	U	AH
0.25	1.78	0.986	2.75	1.125	2.62

TERMINAL BOX				
AA	AB	AC	RD	BV
1/2 NPT	7	5.55	3.95	8.5

FLANGE					
AK	BD	AJ	BF	BB	BC
8.5	8.85	7.25	4*1/2-13	0.25	0.12

PERFORMANCE CURVES

Premium Efficiency Motor:

SSPE5-18-184TC

WorldWide Electric Corporation

1 (800) 808-2131

Worldwideelectric.net



Document Generated: 30-Jan-2023
Document ID:

Customer:

Motor Type	SSPE		FL Speed	1765	
Output Rating (HP)	5		LRT (%FLT)	225	460 volt FLA 6.25
Full Load Torque	14.7	lb.ft	BDT (%FLT)	280	230 volt FLA 12.5
Rotor Wk^2	0.5	lb-ft^2			

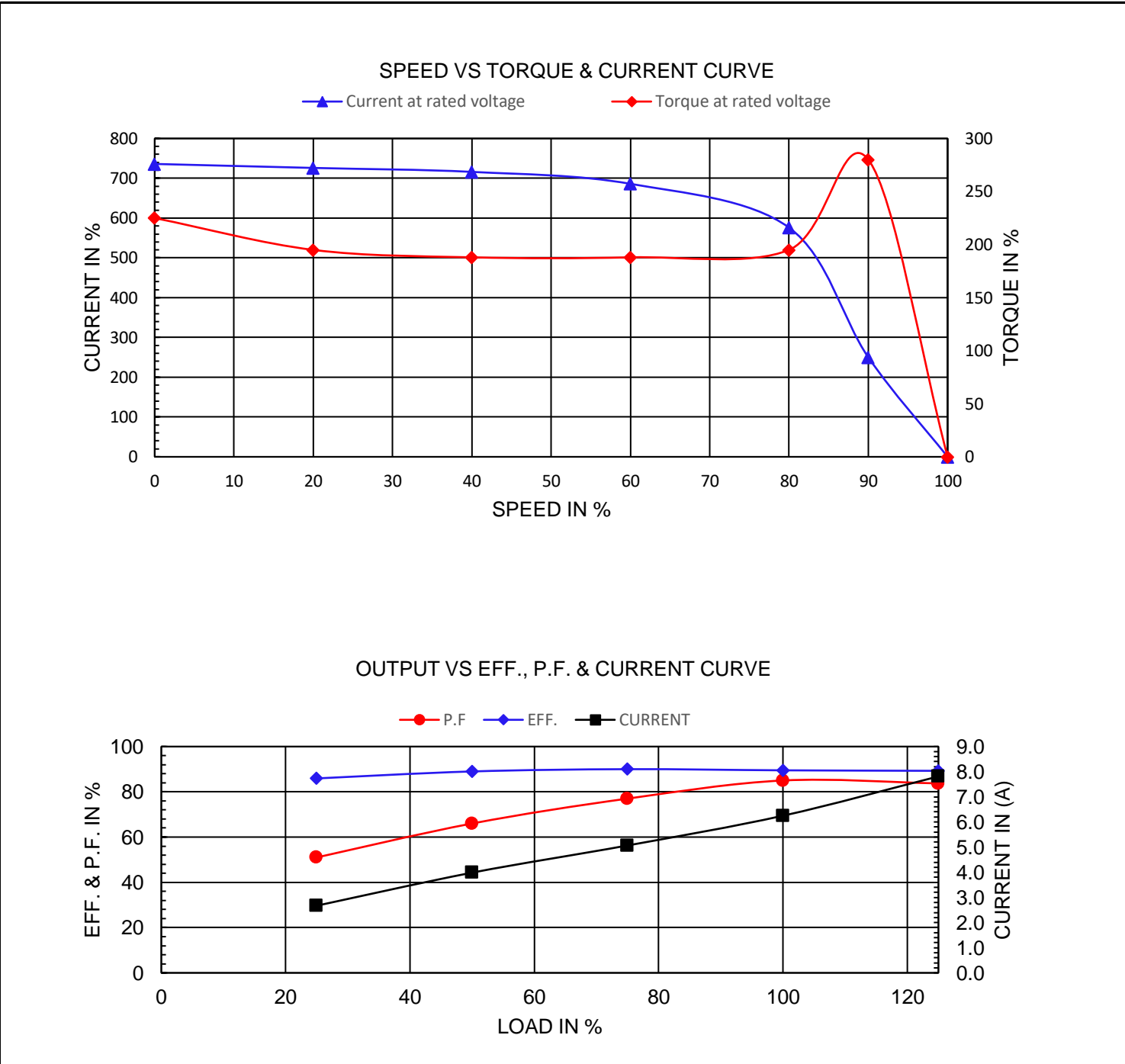

NAMEPLATE / WIRING

Premium Efficiency Motor: **SSPE5-18-184TC**

WorldWide Electric Corporation

1 (800) 808-2131

Worldwideelectric.net



Document Generated: 30-Jan-2023	Customer:
Document ID:	

SAMPLE NAMEPLATE DATA

		THREE PHASE AC INDUCTION MOTOR INVERTER DUTY 20:1 VT 10:1 CT							
Model		FRAME		IP 69K	LB/WT		230V 		
Hz 60	S. F. 1.15	Hz 50	S. F. 1.15	ENCL. TEFC	AMB. 40°C				
HP	RPM	HP	RPM	DUTY CONT	INS. F				
VOLTS 230/460		VOLTS 190/380		NEMA DES. B			460V 		
AMP		AMP		BRG DE					
CODE	P. F.	CODE	P. F.	BRG ODE					
EFF	MIN	IE3 -		NO.					
				 C 502259 US		 E517327		CC082A	

Model	SSPE5-18-184TC			FRAME	184TC	LB/WT	100 lbs.
Hz	60	S.F.	1.15	Hz	50	S.F.	1.15
HP	5	RPM	1765	HP	3	RPM	1465
VOLTS	230/460			VOLTS	190/380		
AMPS	12.5/6.25			AMPS	9/4.5		
CODE	J	P.F.	0.85	CODE	K	P.F.	0.85
EFF	89.5%	MIN	89%	IE3 -	86.7%		
BRG DE	6308 2RS						
BRG ODE	6306 2RS						